



Nuvation Energy Grid Battery Controller

Installation Guide

Document ID: NE-IG-003 | Revision: 2.0, 2020-03-13

Table of Contents

Important Safety Information	1
1. Introduction	2
1.1. About this Guide	2
2. System Overview	3
3. Grid Battery Controller	5
3.1. Overview	5
3.2. Mechanical Dimensions	5
3.3. Electrical Connections	7
3.3.1. DC Power Connector	7
3.4. Network Connections	8



Important Safety Information

The content in this document must be followed in order to ensure safe operation of Nuvation Energy BMS.



Do **NOT** energize the system until all connections to the Cell Interface and Power Interface modules have been made.



Insulated handling is required of any connector carrying potentials over 600 V DC relative to chassis.



Properly insulate or remove any unused wires. Unused wires can couple excessive system noise into Nuvation Energy BMS which can disrupt communication and lead to undesirable behaviors.



Please be aware of high voltages present in your system and follow all necessary safety precautions.



The provided module enclosures are not fire enclosures.

Depending on battery chemistry, there might be a nominal voltage per cell which adds up in series and is always present. There are many different battery chemistries with different current capacities, and so high voltage with high current capacity may be present while connecting Nuvation Energy BMS. You must use proper electrical safety precautions when handling any part of Nuvation Energy BMS.



Neither Nuvation Energy or any of its employees shall be liable for any direct, indirect, incidental, special, exemplary, personal or consequential harm or damages (including, but not limited to, procurement or substitute goods or services; loss of use, data, or profits; or business interruption) however caused and on any theory of liability, whether in contract, strict liability, or tort (including negligence or otherwise) arising in any way out of the use of this product.



Nuvation Energy BMS relies on your system charger to charge the battery cells; do not leave your charger off while Nuvation Energy BMS is powered from the stack for prolonged periods of time. Nuvation Energy BMS should be shut down when the system is in storage to minimize the drain on the cells.

1. Introduction

Thank you for choosing Nuvation Energy BMS.

Nuvation Energy BMS is an enterprise-grade battery management system with features that extend battery life, ensuring pack-level safety, data-analytics, and remote management.

The Nuvation Energy Grid Battery Controller aggregates information and provides a unified interface to a large multi-stack battery system.

You can take advantage of the highly configurable browser-based user interface and custom-tune Nuvation Energy Grid Battery Controller to your specific target application.

1.1. About this Guide

This *Nuvation Energy Grid Battery Controller: Installation Guide* provides instructions to connect your Nuvation Energy Grid Battery Controller to your Nuvation Energy BMS.

Once you have successfully completed the installation process, please follow instructions in the *Operator Interface Manual: Multi-Stack* for accessing and configuring the Multi-Stack Operator Interface.

We thrive on your feedback and what we build is driven by your input. Please submit support tickets to support@nuvationenergy.com.

2. System Overview

Nuvation Energy Grid Battery Controller aggregates information in a multi-stack energy storage system and provides a unified interface for monitoring, updating and controlling the individual stacks and even external hardware.

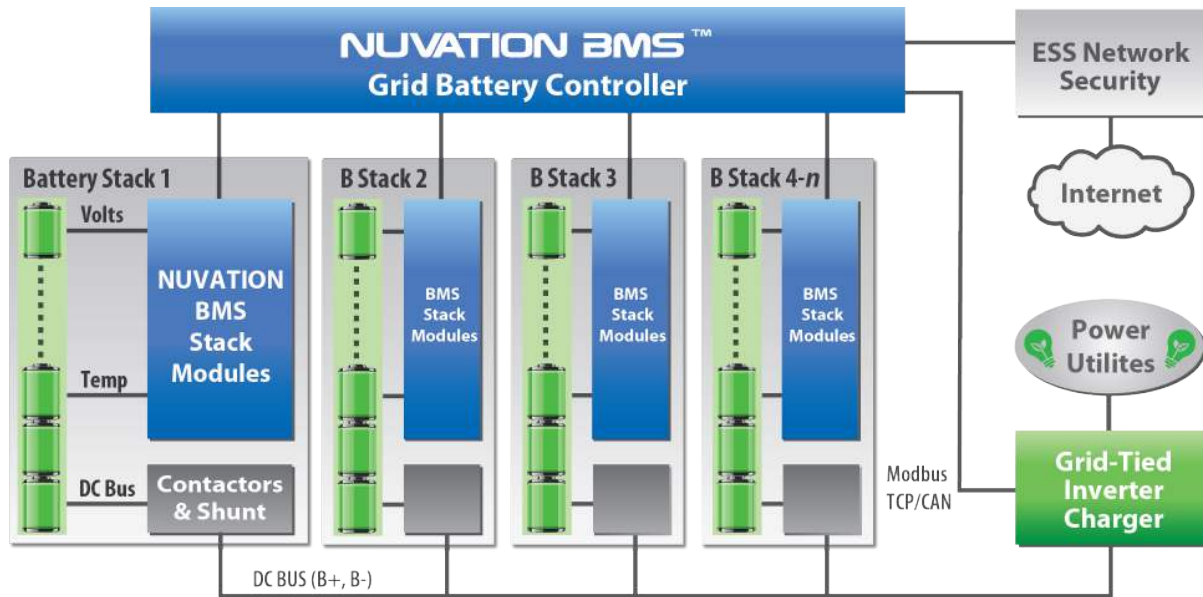

Multi-Stack View: Grid ESS Managed by Nuvation BMS

Figure 1. Example Nuvation Energy BMS multi-stack configuration

Depending on the system, the individual stacks will be managed by either a Nuvation Energy High-Voltage BMS (via the Stack Controller) or a Nuvation Energy Low-Voltage BMS (via the Battery Controller).

The Grid Battery Controller aggregates information from each of the Stack Controller modules or Battery Controller modules in the system and provides a unified interface to the pack as a whole.

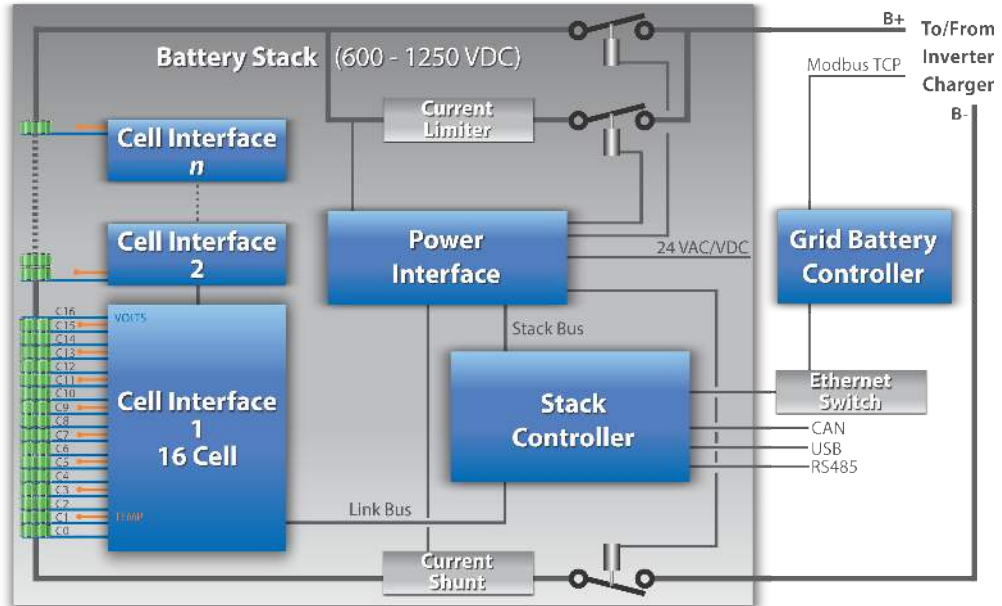

BMS Single Stack Detail - Energy Storage System (ESS)

Figure 2. Example single-stack managed by a Stack Controller and connected to a Grid Battery Controller

3. Grid Battery Controller

3.1. Overview

Nuvation Energy Grid Battery Controller provides two crucial battery-level software interfaces for large, multi-stack battery applications:

1. Modbus TCP:

- Unified view of the entire battery conforming to open energy standards.
- Conforms to MESA Models: S801, S802 and S803
- Used directly by inverters and other grid infrastructure implementing the MESA standard

2. Web-based configuration and diagnostics:

- Hosts web-based tools that can be accessed from common web browsers
- Used to provision firmware upgrades, configure settings and view diagnostic information for the entire battery system

A few key system-level features that are also provided are:

- System-wide statistics for voltages, temperature and currents
- Current limiting algorithms for multi-stack battery systems
- State-of-Charge algorithms for multi-stack battery systems
- NTP client for BMS time synchronization

The Grid Battery Controller uses a Linux-based operating system with special provisions in place to guarantee the performance and responsiveness required for real-time inverter control.

3.2. Mechanical Dimensions

The overall dimensions of the Grid Battery Controller are 210 mm X 65 mm X 140 mm. It is sold standard with a DIN clip, enabling it to be securely mounted to EN50022-compliant DIN rail. Extra space should be provided around the module to allow for cable connections, easy installation/maintenance and to provide adequate fan-less cooling. The spatial clearance is illustrated on the [restricted area diagram](#)

The Grid Battery Controller weighs approximately 2.5 kg.

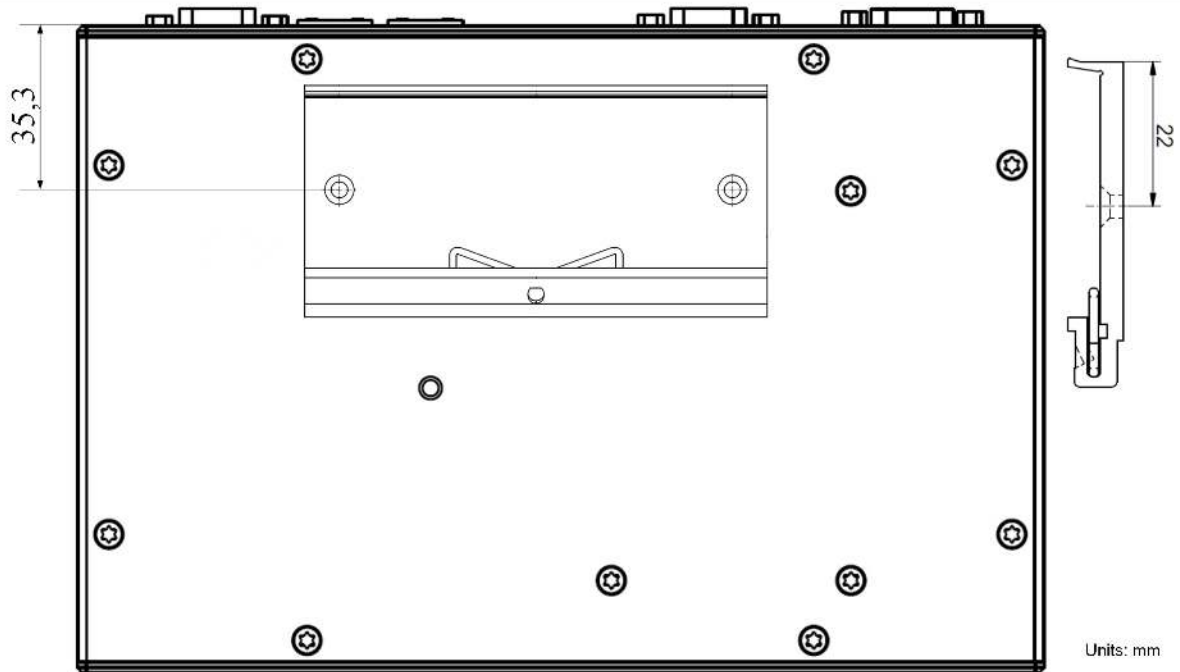

Figure 3. Grid Battery Controller DIN Clip Location

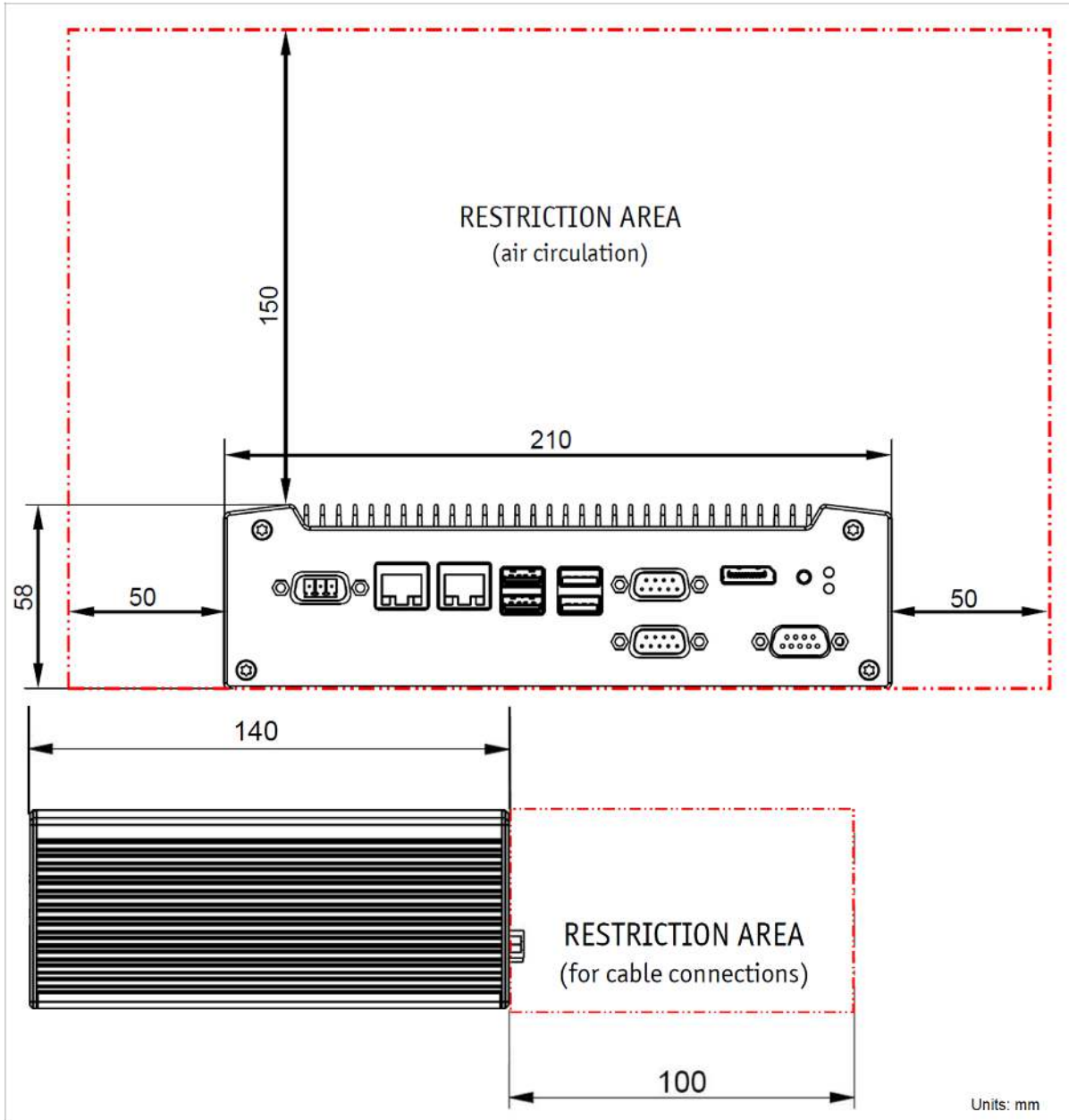

Figure 4. Grid Battery Controller Restricted Areas

3.3. Electrical Connections

Grid Battery Controller has standard connectors excluding the DC power connector.

3.3.1. DC Power Connector

The DC power connector provides a nominal 24VDC to the Grid Battery Controller, but will tolerate an input voltage between 19.2V and 28.8V. At 24V, it consumes no more than 2.5A.



The external supply has its negative input connected to earth ground through the Grid Battery Controller’s chassis.

Table 1. DC Power: MINI-COMBICON DSUB Connector



Phoenix Contact 1841909	
Manufacturer	Phoenix Contact
Housing	1841909
Housing material	Polyamide UL94V-0
Circuits	3
Wire gauge range	AWG16-24 stranded

Table 2. DC Power Connector Pin Assignment

Pin	Connection	Description	Connected to Device
1	GND	External Power Supply Input Negative	Connect to external 24Vdc power supply negative
2	No Connect	Not Connected	No Connect
3	+24V	External Power Supply Input Positive	Connect to external 24Vdc power supply positive

3.4. Network Connections

The Grid Battery Controller has two ethernet ports on it’s front panel labeled ETH1 and ETH2. These ports manage two separate network connections which are named described as the *external* and *internal* networks. The ETH2 port connects to the *external* network. The *external* network provides services such as DHCP and NTP for the Grid Battery Controller. An external controller or integration software would communicate to the Grid Battery Controller over this network. The ETH1 port connects the Grid Battery Controller to its *internal* network. The *internal* network allows the Grid Battery Controller to connect to and communicate with the Nuvation Energy High-Voltage Stack Controller for each stack in the battery pack. For more details on how to configure the network settings on these ethernet ports, refer to the *Software Reference Manual: Multi-Stack* available online at <https://www.nuvationenergy.com/technical-resources>



The *external* and *internal* networks of the Grid Battery Controller should remain separated for the best operation of the battery pack. Excessive network traffic on the *internal* network can interfere with the Grid Battery Controller management of the stacks.

From time to time Nuvation Energy will make updates to Nuvation Energy BMS in response to changes in available technologies, client requests, emerging energy storage standards, and other industry requirements. The product specifications in this document, therefore, are subject to change without notice.

© 2020 Nuvation Energy