



# Nuvation Energy High-Voltage BMS

## Datasheet

Document ID: NE-DS-005 | Revision: 2.9, 2022-05-27

# Table of Contents

- 1. System Overview . . . . . 1
  - 1.1. Stack Switchgear . . . . . 4
  - 1.2. Cell Interface . . . . . 5
- 2. Operating Limits . . . . . 6
  - 2.1. Stack Switchgear . . . . . 6
    - 2.1.1. External Specifications . . . . . 6
    - 2.1.2. Electrical Characteristics . . . . . 6
    - 2.1.3. Environmental Conditions . . . . . 7
    - 2.1.4. Standards and Certifications . . . . . 7
  - 2.2. Cell Interface . . . . . 8
    - 2.2.1. Electrical Characteristics . . . . . 8
    - 2.2.2. Environmental Conditions . . . . . 9
    - 2.2.3. Standards and Certifications . . . . . 9
    - 2.2.4. Maximum Stack Deployment . . . . . 9
      - 2.2.4.1. Limits Due to Link Bus Power . . . . . 9
      - 2.2.4.2. Limits Due to Cell Voltage Scan Rate . . . . . 10
- 3. Mechanical Overview . . . . . 11
  - 3.1. Stack Switchgear . . . . . 11
    - 3.1.1. Front-securing Rack-Mount, 19" . . . . . 13
    - 3.1.2. 2-Post Rack-Mount, 19" And 23" . . . . . 15
    - 3.1.3. Shelf-Mount . . . . . 18
  - 3.2. Cell Interface . . . . . 20
    - 3.2.1. Optional DIN rail mounting Kit . . . . . 20
- 4. Ordering Information . . . . . 22
  - 4.1. Stack Switchgear . . . . . 22
  - 4.2. Cell Interface . . . . . 23
- 5. Document Revision History . . . . . 24

# 1. System Overview

The Nuvation Energy High-Voltage BMS provides cell-level and stack-level control for battery stacks up to 1250 VDC. The UL 1973 Recognized BMS modules in each stack ensure safe battery operation and significantly reduce the effort of certifying the energy storage solution to meet UL 1973 and UL 9540. While the Stack Switchgear does not yet have UL 1973 recognition, it has been designed to enable UL 1973 certification of the battery stack. For more information, please contact [support@nuvationenergy.com](mailto:support@nuvationenergy.com)



**Figure 1. High-Voltage BMS**

A single Nuvation Energy Stack Switchgear unit manages each stack and connects it to the DC bus of the energy storage system. The Nuvation Energy Stack Switchgear, is a pre-configured assembly that incorporates the major functions of Nuvation Energy High-Voltage BMS into a rack-mountable unit which includes stack monitoring, electrical disconnects, pre-charging, current sensing, fuses, and a safety relay for E-Stop. It also includes supporting components like power supplies, indicator LEDs, and external-facing connectors.

Cell Interface modules in each stack connect directly to battery cells to measure cell voltages and temperatures and provide cell balancing.

The Stack Switchgear and Cell Interface modules operate together as a complete system called the High-Voltage BMS. Available units/modules are listed below.

**Table 1. Stack Switchgear and Cell Interface Modules**

Model	Unit/Module Name
NUVSSG-1250	Stack Switchgear, 1250 V
NUV100-CI-12-1	Cell Interface - 12 channel
NUV100-CI-16-1	Cell Interface - 16 channel
NUV100-CI-4M12-1	Cell Interface - 12 V 4 channel

Generally, a single battery stack uses one Stack Switchgear and one or more Cell Interface modules. A breakdown of a single battery stack is shown in [Figure 2](#)

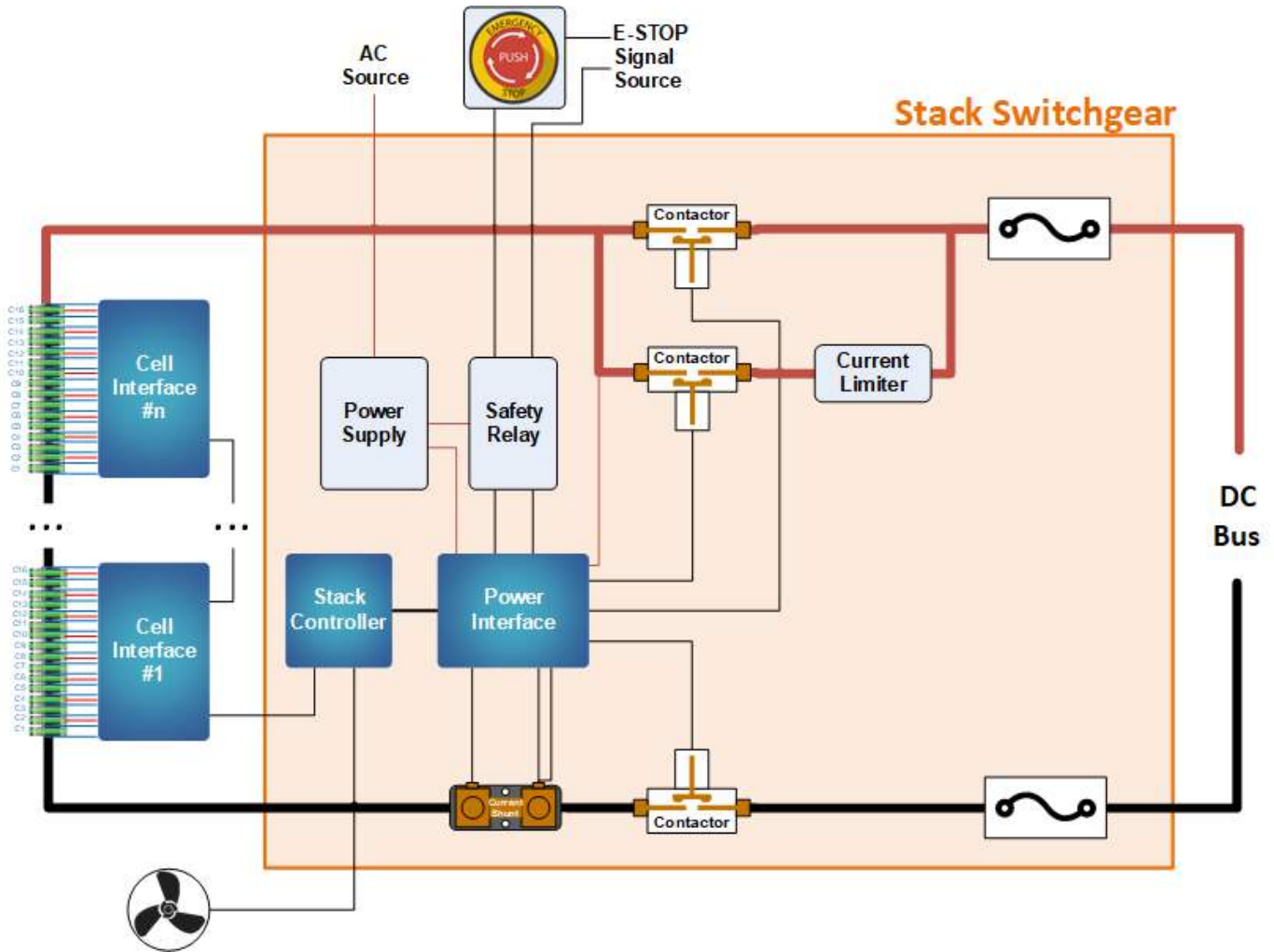

**Figure 2. High-Voltage BMS single system diagram**

In a multi-stack High-Voltage BMS configuration, as shown in [Figure 3](#), each Stack Switchgear unit is responsible for monitoring the state and safety of one battery stack. All Stack Switchgear units connected to a single common DC bus in the system may be managed by a single Nuvation Energy Multi-Stack Controller, where an Operator Interface provides a unified view and central control of the multi-stack system.

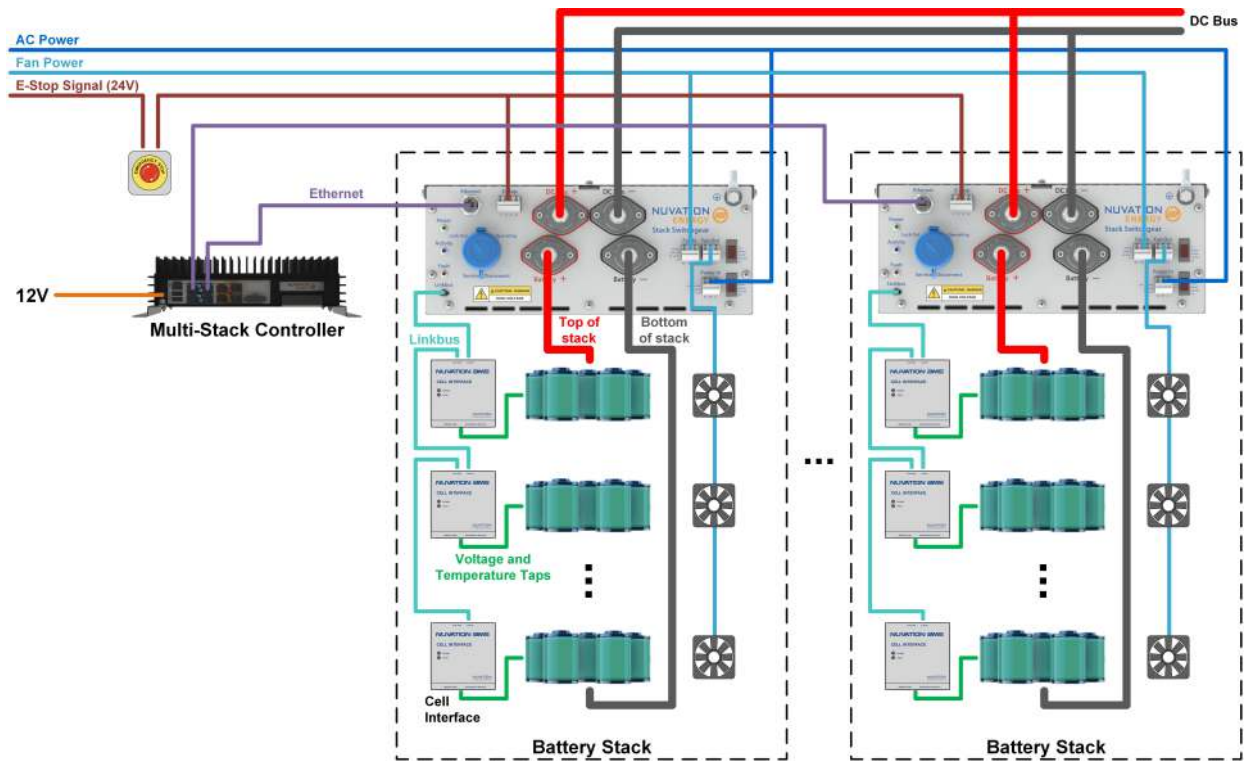
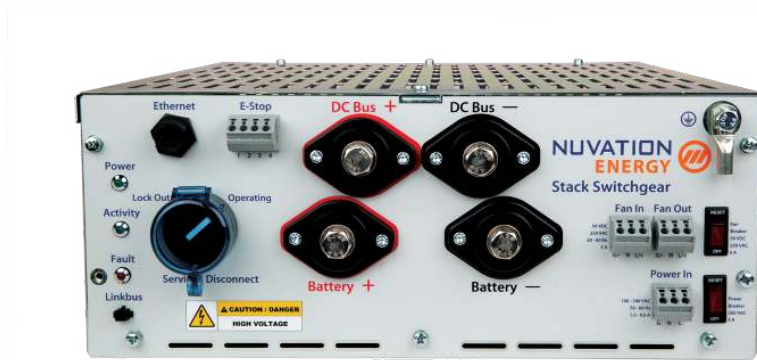

**Figure 3. High-Voltage BMS multi-stack diagram**

## 1.1. Stack Switchgear

The high-level system design of Stack Switchgear is shown in [Figure 2](#). Within a battery stack, the Stack Switchgear connects to the daisy-chained Nuvation Energy Cell Interface modules. The Cell Interface modules convert cell voltage and temperature measurements to digital values to be relayed to the Stack Switchgear, and enable or disable cell balancing as required. Daisy-chaining the Cell Interface modules facilitates the design of flexible and scalable battery energy storage systems.

The Stack Switchgear has high-voltage, high-current connectors that are accessible on the front of the unit. These connect the battery stack to the rest of the system, which is typically a common DC bus. Safety precautions are required to handle and connect cables into this unit.



**Figure 4. Nuvation Energy Stack Switchgear Unit**

The external interfaces to this unit are:

- Battery Stack and DC Bus connectors
- 10/100 Base-T Ethernet RJ45 jack (Modbus-TCP)
- Link Bus connector
- E-stop connector
- Fan control connectors with breaker switch
- Power In connector with breaker switch
- Status LEDs (Power, Activity, and Fault)
- Earth bonding connection (grounding stud)

The Stack Switchgear (NUVSSG-1250) supports 1250 VDC. There are multiple options for current rating (from 100 A to 350 A) and fuse rating (from 200 A to 500 A). The Stack Switchgear fuse rating is determined by the application power profile which is based on continuous power, cycle duration, and cycle frequency.

For ordering details, please refer to [Stack Switchgear Ordering Information](#).

## 1.2. Cell Interface

The Nuvation Energy Cell Interface is the direct link between the individual battery stack cells and the rest of the battery management system. It facilitates battery monitoring and balancing functionalities.

In a stack managed by the Stack Switchgear, one or more Cell Interface modules are used to convert and relay cell voltage and temperature measurements digitally to the Stack Switchgear. When using multiple Cell Interface modules, the same Cell Interface variant must be used—i.e. all NUV100-CI-12-1, or all NUV100-CI-16-1, or all NUV100-CI-4M12-1. The firmware does not support a mixed chain of different Cell Interface variants.

The following are variants of the Nuvation Energy Cell Interface:

- The NUV100-CI-12-1, Cell Interface - 12 channel can monitor up to 12 series-connected cells
- The NUV100-CI-16-1, Cell Interface - 16 channel can monitor up to 16 series-connected cells
- The NUV100-CI-4M12-1, Cell Interface - 12 V 4 channel can monitor up to 4 series-connected 12V lead-acid cells. Note that cell balancing is not supported in Cell Interface - 12 V 4 channel.



**Figure 5. Nuvation Energy Cell Interface Module**

The external interfaces to this module are:

- Battery cells connector
- Temperature sensors connector
- 2 Link Bus connectors
- 2 Indicator LEDs



The Cell Interface connects to the battery stack-referenced signals through high voltage rated connectors. Safety precautions are required to handle and connect cables into this module.

## 2. Operating Limits

### 2.1. Stack Switchgear



Exceeding the ratings will damage the system.

#### 2.1.1. External Specifications

Symbol	Parameter	Min	Typ	Max	Units
$V_{input}$	Input Voltage	100	-	240	V AC
$P_{input}$	Input Power	-	33.7	60	W
$f_{input}$	Input Frequency	45	50/60	65	Hz
$V_{fan\_DC}$	Cooling Fan DC Voltage	-	-	50	V DC
$V_{fan\_AC}$	Cooling Fan AC Voltage	-	-	250	V AC
$I_{fan}$	Cooling Fan Current	-	-	5	A DC/AC
$I_{E-Stop}$	E-Stop Input Current Rating	-	-	9.6	mA DC
$V_{E-Stop}$	E-Stop Input Voltage Rating	19.2	24	28.8	V DC

#### 2.1.2. Electrical Characteristics

Symbol	Parameter	Min	Typ	Max	Units
<b>Stack Voltage Specifications</b>					
$V_{stack\_ov}$	Stack Over-Voltage Threshold (triggers contactors to open)	0	Configurable	1250	V DC
$V_{stack\_uv}$	Stack Under-Voltage Threshold (triggers contactors to open)	0	Configurable	-	V DC
<b>Battery Cell Specifications</b>					
$C_{ov}$	Cell Over-Voltage Threshold (triggers contactors to open)	-	Configurable	-	V
$C_{uv}$	Cell Under-Voltage Threshold (triggers contactors to open)	-	Configurable	-	V
<b>Temperature Sensors Specifications</b>					
$T_{ut}$	Under-Temperature Threshold (triggers contactors to open)	-	Configurable	-	°C
$T_{ot}$	Over-Temperature Threshold (triggers contactors to open)	-	Configurable	-	°C
$T_{fan\_en}$	Fan Enable Temperature Threshold	-	Configurable	-	°C
<b>Contactor Opening Specifications</b>					
$I_{cont\_max}$	One time contactor maximum breaking current	-	-	1260	A DC

Symbol	Parameter	Continuous	Max*	Units
<b>Stack Switchgear Configuration: 1250 V DC, 100 A</b>				
$I_{discharge\_oc}$	Stack Discharging Over-Current (triggers contactors to open)	100	150	A DC
$I_{charge\_oc}$	Stack Charging Over-Current (triggers contactors to open)	100	150	A DC
<b>Stack Switchgear Configuration: 1250 V DC, 200 A</b>				
$I_{discharge\_oc}$	Stack Discharging Over-Current (triggers contactors to open)	200	250	A DC
$I_{charge\_oc}$	Stack Charging Over-Current (triggers contactors to open)	200	250	A DC
<b>Stack Switchgear Configuration: 1250 V DC, 300 A</b>				
$I_{discharge\_oc}$	Stack Discharging Over-Current (triggers contactors to open)	300	350	A DC
$I_{charge\_oc}$	Stack Charging Over-Current (triggers contactors to open)	300	350	A DC



Symbol	Parameter	Continuous	Max*	Units
<b>Stack Switchgear Configuration: 1250 V DC, 350 A</b>				
I <sub>discharge_oc</sub>	Stack Discharging Over-Current (triggers contactors to open)	350	400	A DC
I <sub>charge_oc</sub>	Stack Charging Over-Current (triggers contactors to open)	350	400	A DC

\* The Stack Switchgear can handle short current overages above the continuous rating. Any charge or discharge current above the continuous rating must not exceed 5 minutes per hour and must not exceed the specified max rating. Sufficient time to allow the system to cool down afterward is required.

### 2.1.3. Environmental Conditions

Symbol	Parameter	Min	Typ	Max	Units
<b>Thermal Specifications</b>					
T <sub>a</sub>	Operating Temperature	10	25	40	°C
	Storage Temperature	-10	25	40	°C
<b>Humidity Specifications</b>					
RH	Operating Relative Humidity	5	-	85	%
	Storage Relative Humidity	5	-	85	%
<b>Shock and Vibration Specifications</b>					
Vertical	Vertical shock/vibration	-	-	10	m/s <sup>2</sup>
Longitudinal	Longitudinal shock/vibration	-	-	10	m/s <sup>2</sup>
Transverse	Transverse shock/vibration	-	-	10	m/s <sup>2</sup>
Pulse vibration	On each axis	-	-	245	m/s <sup>2</sup>

The Nuvation Energy Stack Switchgear has been designed to meet the requirements of SAE J2464 (shock) and SAE J2380 (random vibration). For transportation, it is recommended that the Stack Switchgear be shipped in its original packaging via pallet whenever possible.

### 2.1.4. Standards and Certifications

Standard/Certification		
Stationary Battery Safety	UL Recognized (internal Power Interface and Stack Controller modules)	UL 1973 (file no. MH64071)
Functional Safety	UL Recognized (internal Power Interface and Stack Controller modules)	UL 991 (file no. MH64071) UL 1998 (file no. MH64071)

UL 1973 recognition ensures safe battery operation and significantly reduces the effort of certifying the energy storage solution to meet UL 1973 and UL 9540.

## 2.2. Cell Interface



Exceeding the maximum ratings will damage the Cell Interface module.

### 2.2.1. Electrical Characteristics

Symbol	Parameter	Conditions	Min	Typ	Max	Units
<b>Link In Specifications</b>						
+V <sub>BUS</sub>	Input Voltage	-	9	24	60	V DC
	Input Current, CI-12	+VBUS = 24 V DC, Link Out disconnected	-	-	25.5	mA DC
	Input Current, CI-16 and CI-4M12	+VBUS = 24 V DC, Link Out disconnected	-	-	31.7	mA DC
I <sub>P_LINK</sub>	Output Current	-	-	-	20	mA DC
I <sub>N_LINK</sub>	Output Current	-	-	-	20	mA DC
<b>Link Out Specifications</b>						
+V <sub>BUS</sub>	Output Voltage	-	-	+VBUS	-	V DC
	Output Current per CI-12	+VBUS = 24 V DC	-	-	25.5	mA DC
	Output Current per CI-16 and CI-4M12	+VBUS = 24 V DC	-	-	31.7	mA DC
I <sub>P_LINK</sub>	Output Current	-	-	-	20	mA DC
I <sub>N_LINK</sub>	Output Current	-	-	-	20	mA DC
<b>Battery Cells Specifications</b>						
C <sub>(n)</sub> - C <sub>(n-1)</sub>	Input Cell Voltage Range	CI-12, CI-16	0	-	5	V DC
B <sub>(n)</sub> - B <sub>(n-1)</sub>	Input Block Voltage Range	CI-4M12	5	-	20	V DC
V <sub>sum</sub>	Voltage between C0 and C12	CI-12, +VBUS = 0 V DC	11	-	60	V DC
	Voltage between C0 and C8	CI-16, +VBUS = 0 V DC	11	-	40	V DC
	Voltage between C8 and C16	CI-16, +VBUS = 0 V DC	11	-	40	V DC
	Voltage between B0 and B2	CI-4M12, +VBUS = 0 V DC	11	-	40	V DC
	Voltage between B2 and B4	CI-4M12, +VBUS = 0 V DC	11	-	40	V DC
TME	Total Measurement Error	CI-12, CI-16, +VBUS = 24 V DC	±0.1	±1.2	±1.6	mV DC
	Total Measurement Error	CI-4M12, +VBUS = 24 V DC	±2.0	±8.0	±10.0	mV DC
I <sub>(n)</sub>	Cell Balancing Current (only for CI-12 and CI-16)	C(n) - C(n-1) = 4 V DC	304	307	310	mA DC
V <sub>bal</sub>	Cell Voltage for Balancing	CI-12 and CI-16	1.1	-	-	V DC
V <sub>ins</sub>	Internal reinforced insulation rating from Chassis/COM	-	-	-	1250	V DC
<b>Temperature Sensors Specifications</b>						
I <sub>(n)</sub>	Output Current to Temperature Sensor	-	-	-	300	µA
R <sub>t(n)</sub>	Temperature Sensor Resistance at 25 °C	-	-	10	-	kΩ
T <sub>(n)</sub>	Input Temperature Sensor Voltage Range	Cell 0 or Block 0 = 0 V	0	-	3	V
V <sub>ins</sub>	Internal reinforced insulation rating from Chassis/COM	-	-	-	1250	V DC

## 2.2.2. Environmental Conditions

Symbol	Parameter	Min	Typ	Max	Units
<b>Thermal Specifications</b>					
T <sub>a</sub>	Operating Temperature	-10	25	60	°C
	Storage Temperature	-20	25	60	°C
<b>Humidity Specifications</b>					
RH	Operational RH	5	-	85	%
	Storage RH	5	-	85	%
<b>Shock and Vibration Specifications</b>					
Vertical	Vertical shock/vibration	-	-	10	m/s <sup>2</sup>
Longitudinal	Longitudinal shock/vibration	-	-	10	m/s <sup>2</sup>
Transverse	Transverse shock/vibration	-	-	10	m/s <sup>2</sup>
Pulse vibration	On each axis	-	-	245	m/s <sup>2</sup>

The Cell Interface has been designed to meet the requirements of SAE J2464 (shock) and SAE J2380 (random vibration).

## 2.2.3. Standards and Certifications

The Cell Interface meets industry standards CISPR 22 Class A and IEC/EN 61000-4-2 for EMC/EMI and ESD respectively. It has been designed to meet EN 60950 high voltage creepage/clearance distances for reinforced insulation rated to 1250 V DC. All components are EU RoHS / China RoHS compliant.

Standard/Certification		
Stationary Battery Safety	UL Recognized	UL 1973 (file no. MH64071)
Functional Safety	UL Recognized	UL 991 (file no. MH64071) UL 1998 (file no. MH64071)

UL 1973 recognition ensures safe battery operation and significantly reduce the effort of certifying the energy storage solution to meet UL 1973 and UL 9540.

## 2.2.4. Maximum Stack Deployment

Cell Interface modules are deployed as a daisy chain to monitor the cells of a stack. The maximum number of modules that are supported in a stack depend on two metrics:

- the maximum number of modules that can be powered over Link Bus power (if required)
- the required scan rate of the cell voltage measurements

### 2.2.4.1. Limits Due to Link Bus Power

Max CI-12	Max CI-16	Max CI-4M12
50	40	40

### 2.2.4.2. Limits Due to Cell Voltage Scan Rate

The following are approximate cell voltage scan rates for different lengths of Cell Interface daisy chains where all cells are installed. On the Stack Switchgear, the Measurement Anti-Aliasing Filter is set to OFF.

**Table 2. Cell Voltage Scan Rates for CI-16 and CI-4M12**

Measurement Anti-Aliasing Filter	Cell Interface Chain Length	Scan Rate [Hz]
Off	1	5.53
Off	5	3.32
Off	10	2.22
Off	15	1.74
Off	20	1.38
Off	25	1.15
Off	30	0.91

**Table 3. Cell Voltage Scan Rates for CI-12**

Measurement Anti-Aliasing Filter	Cell Interface Chain Length	Scan Rate [Hz]
Off	1	6.01
Off	5	3.94
Off	10	3.03
Off	15	2.59
Off	20	1.97
Off	25	1.63
Off	30	1.44
Off	35	1.30
Off	40	1.08

## 3. Mechanical Overview

### 3.1. Stack Switchgear

The Stack Switchgear is primarily designed to fit in a standard 19" rack with a 23"-deep cabinet. However, other mounting possibilities are supported, as the following subsections discuss. Depending on the desired application, brackets can be ordered with part numbers listed in [Stack Switchgear Ordering Information](#).

The Stack Switchgear must be installed in a horizontal orientation with the vent-slots pointing up to the sky. The Stack Switchgear is not designed to be installed in any other orientation.

The Stack Switchgear is 4U (rack-units) tall. To maintain safe operating temperatures, it is recommended to leave 1U of space above the unit for airflow. Depending on the environment, active airflow, and ambient temperature, some cases may require additional space.

The unit weighs 23 kg [50.7 lbs].

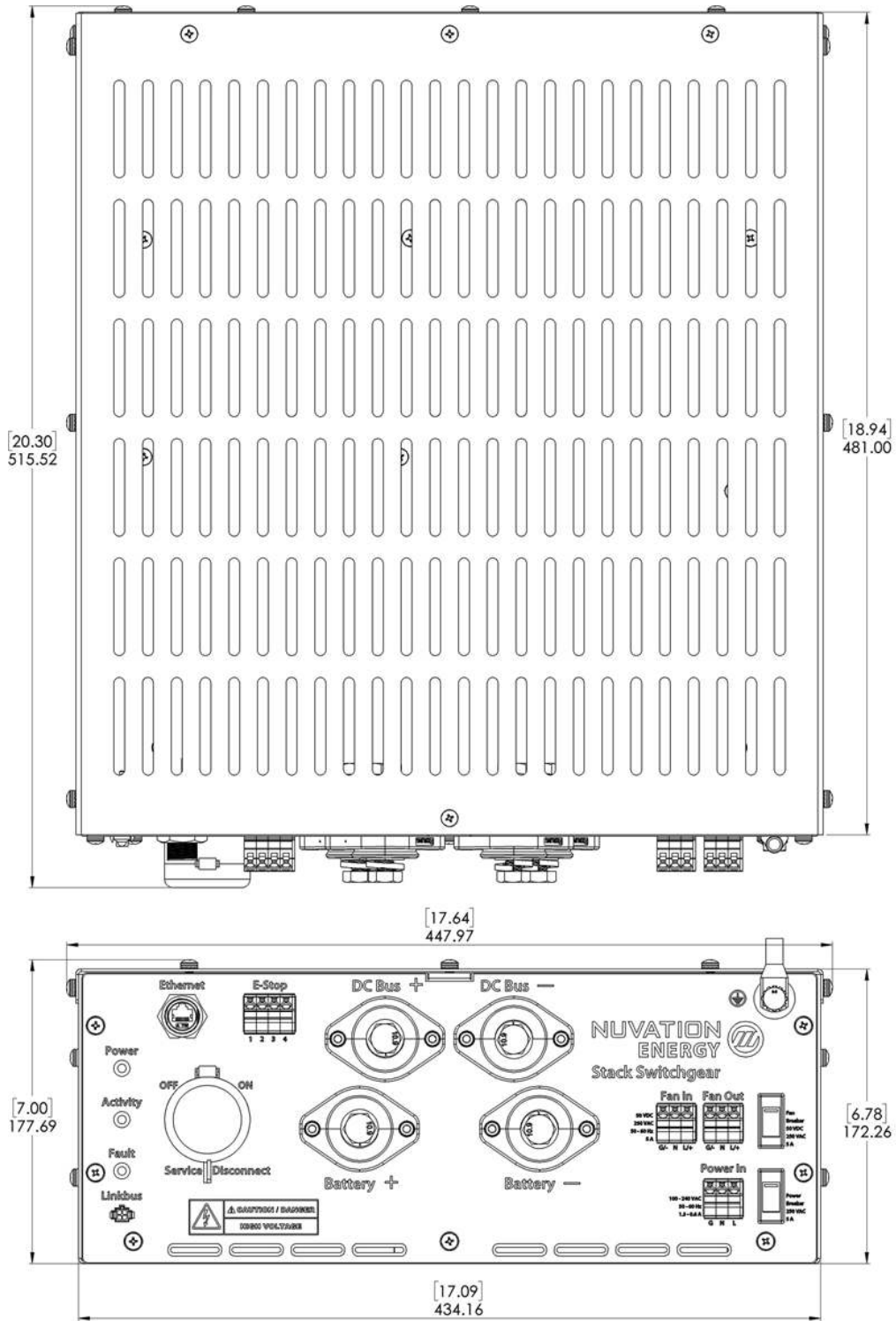

ALL DIMENSIONS IN MM [IN]

**Figure 6. Dimensions, overall**



Please refer to <https://www.nuvationenergy.com/technical-resources> for access to CAD files.

### 3.1.1. Front-securing Rack-Mount, 19"



**Figure 7. Rack-mount, 19", front-securing**

This is the most common use-case for mounting the Stack Switchgear. The mounting brackets allow for adjusting how far the unit protrudes or recedes from the front of the rack. These brackets are designed to secure the front of the unit with respect to the front of the rack.



Third-party side-support angle brackets are necessary to uphold the weight of the unit, in this mounting application.

Some examples include RASA22BK3 or RAAB2436BK products by Hammond Manufacturing (<https://www.hammg.com/>).

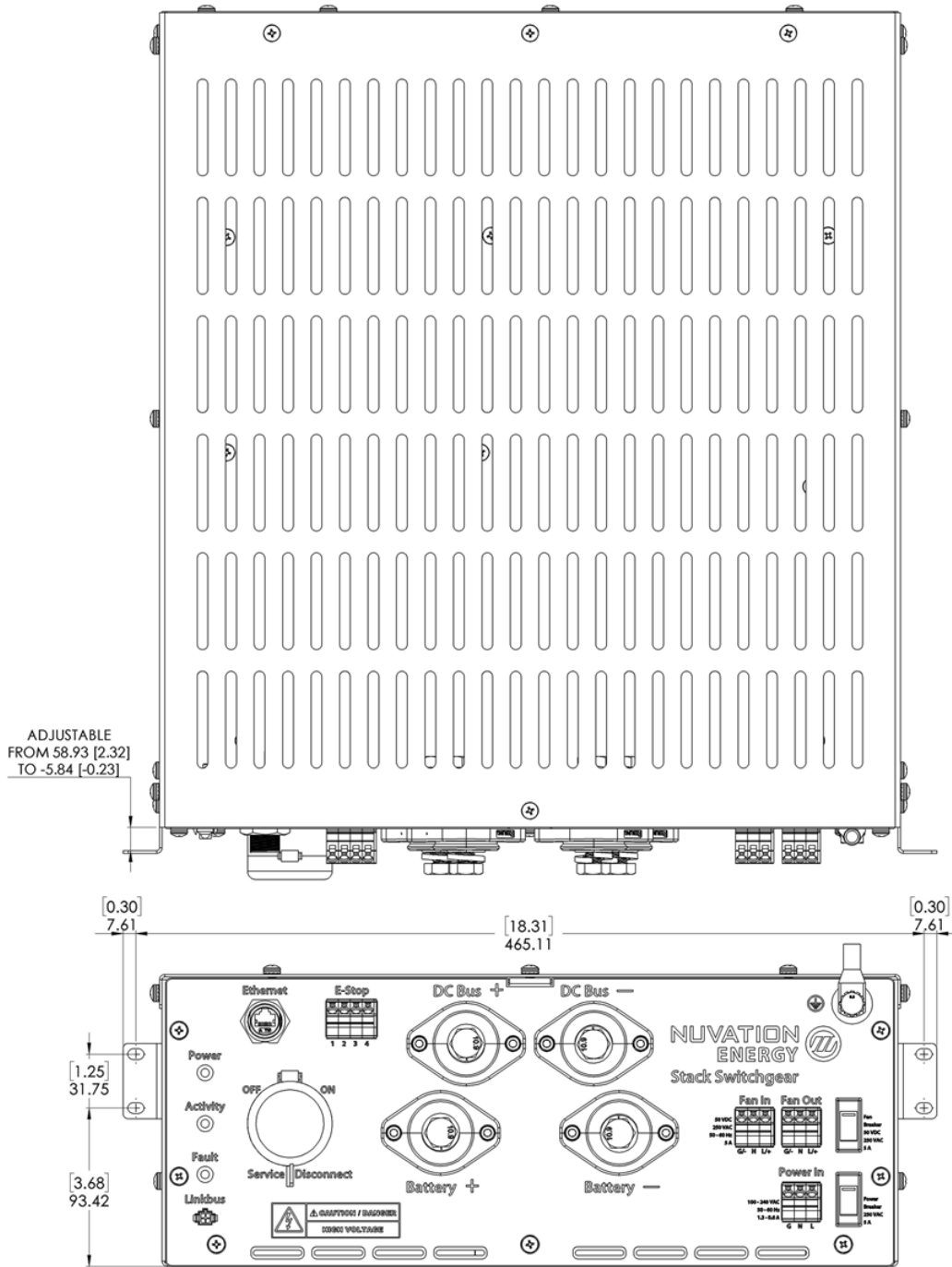

ALL DIMENSIONS IN MM [IN]

**Figure 8. Dimensions, rack-mount, 19", front-securing**



### 3.1.2. 2-Post Rack-Mount, 19" And 23"



**Figure 9. Rack-mount, 2-post, 19"**

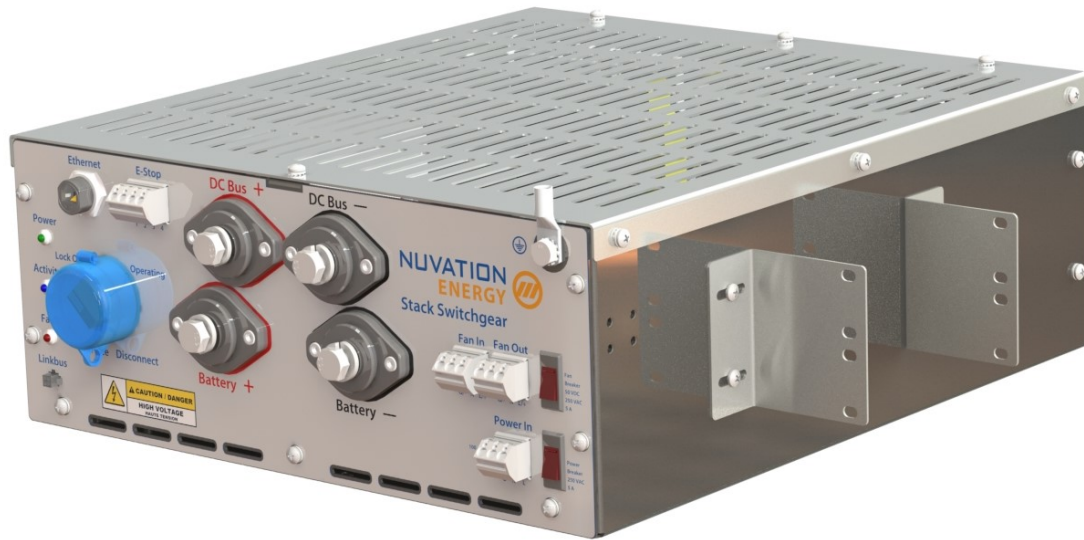

**Figure 10. Rack-mount, 2-post, 23"**

Brackets are available for 2-post open-frame racks.

Note that third-party side-support 2-post-extension brackets are available, *though not necessary*. One example is the RDAB2U26 product by Hammond Manufacturing (<https://www.hamfmfg.com/>).

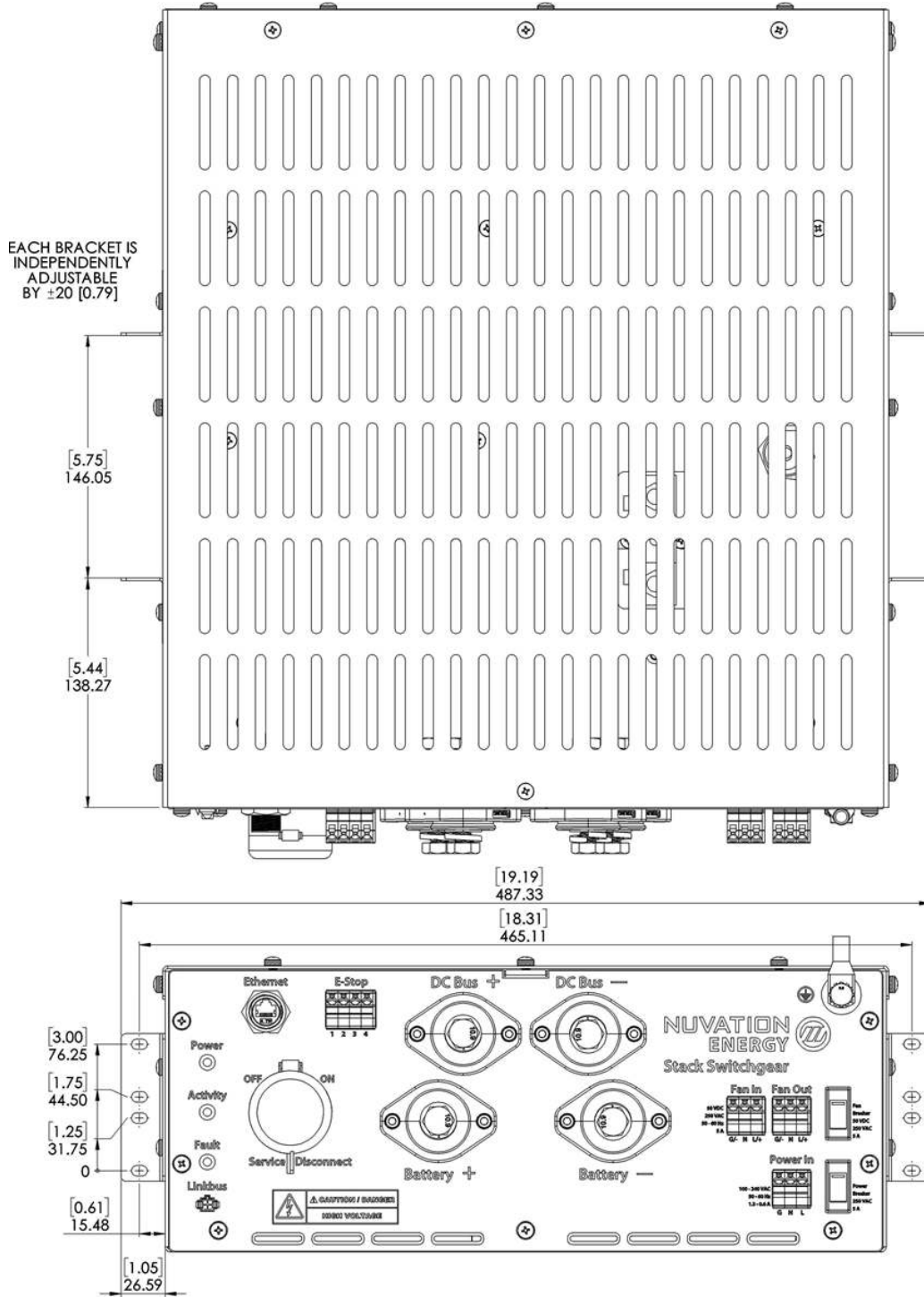

ALL DIMENSIONS IN MM [IN]

**Figure 11. Dimensions, 2-post rack-mount, 19"**

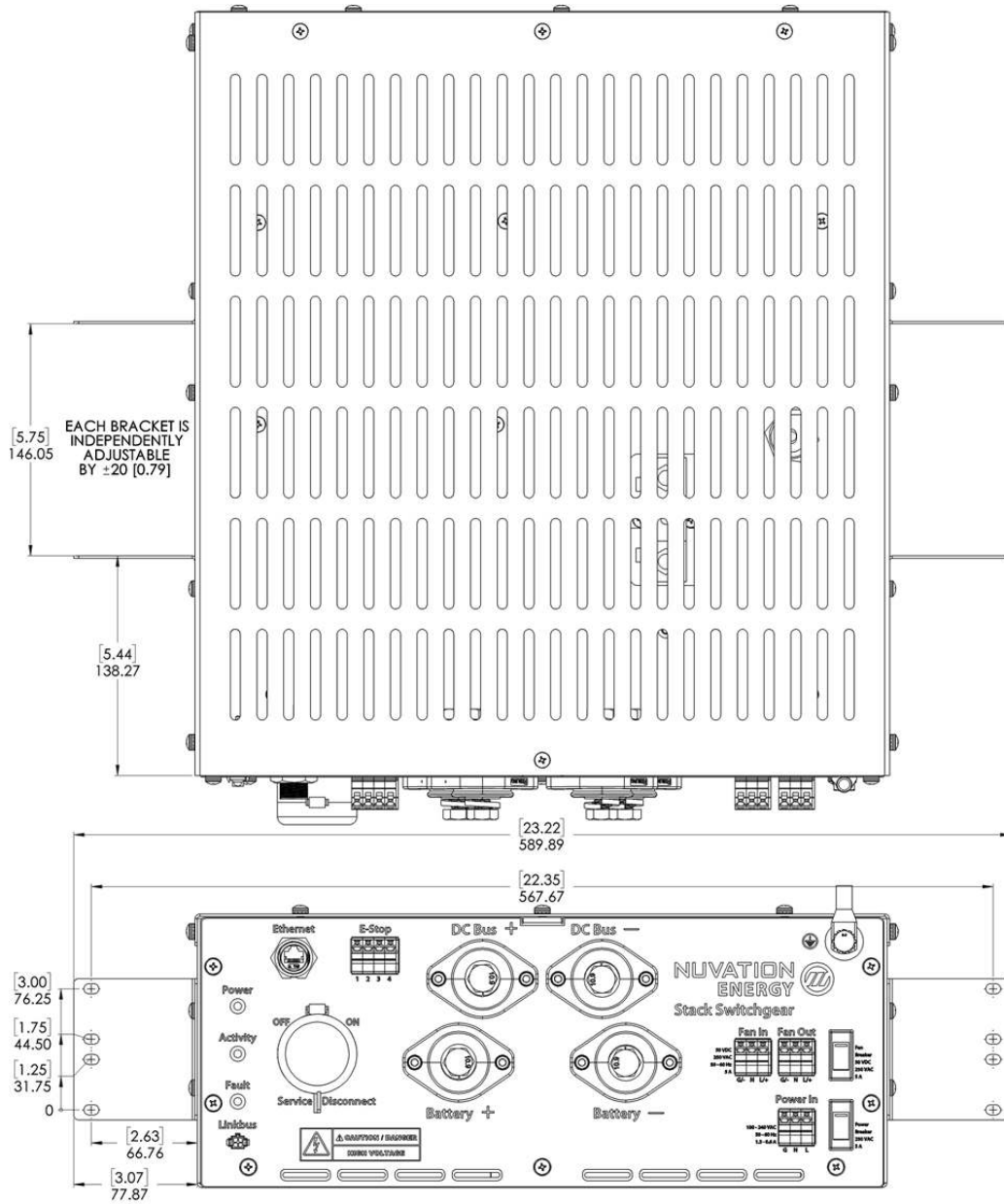

ALL DIMENSIONS IN MM [IN]

**Figure 12. Dimensions, 2-post rack-mount, 23"**

## 3.1.3. Shelf-Mount

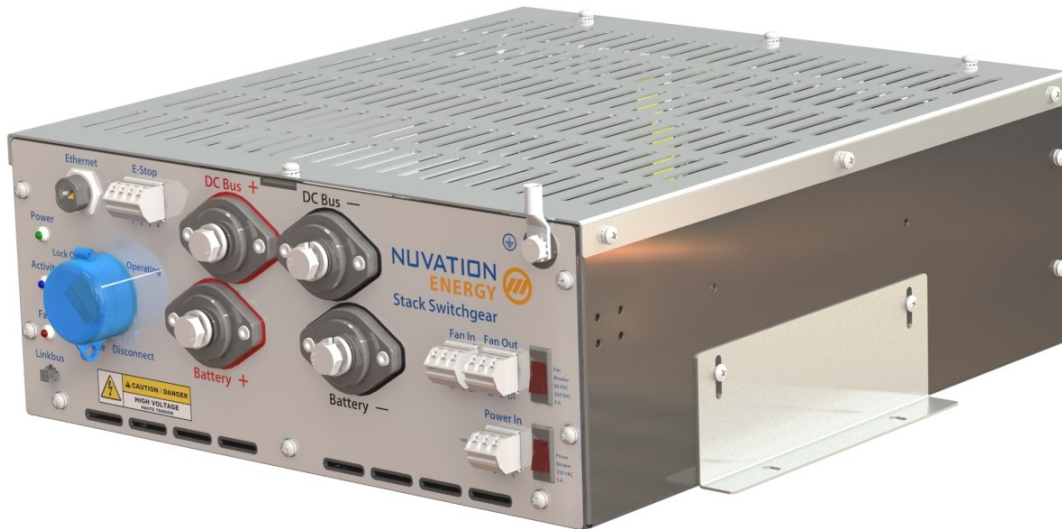

**Figure 13. Shelf-mount**

A Stack Switchgear may also be mounted to the surface on which it rests, with the aid of shelf-mount brackets, as shown in [Figure 13](#)

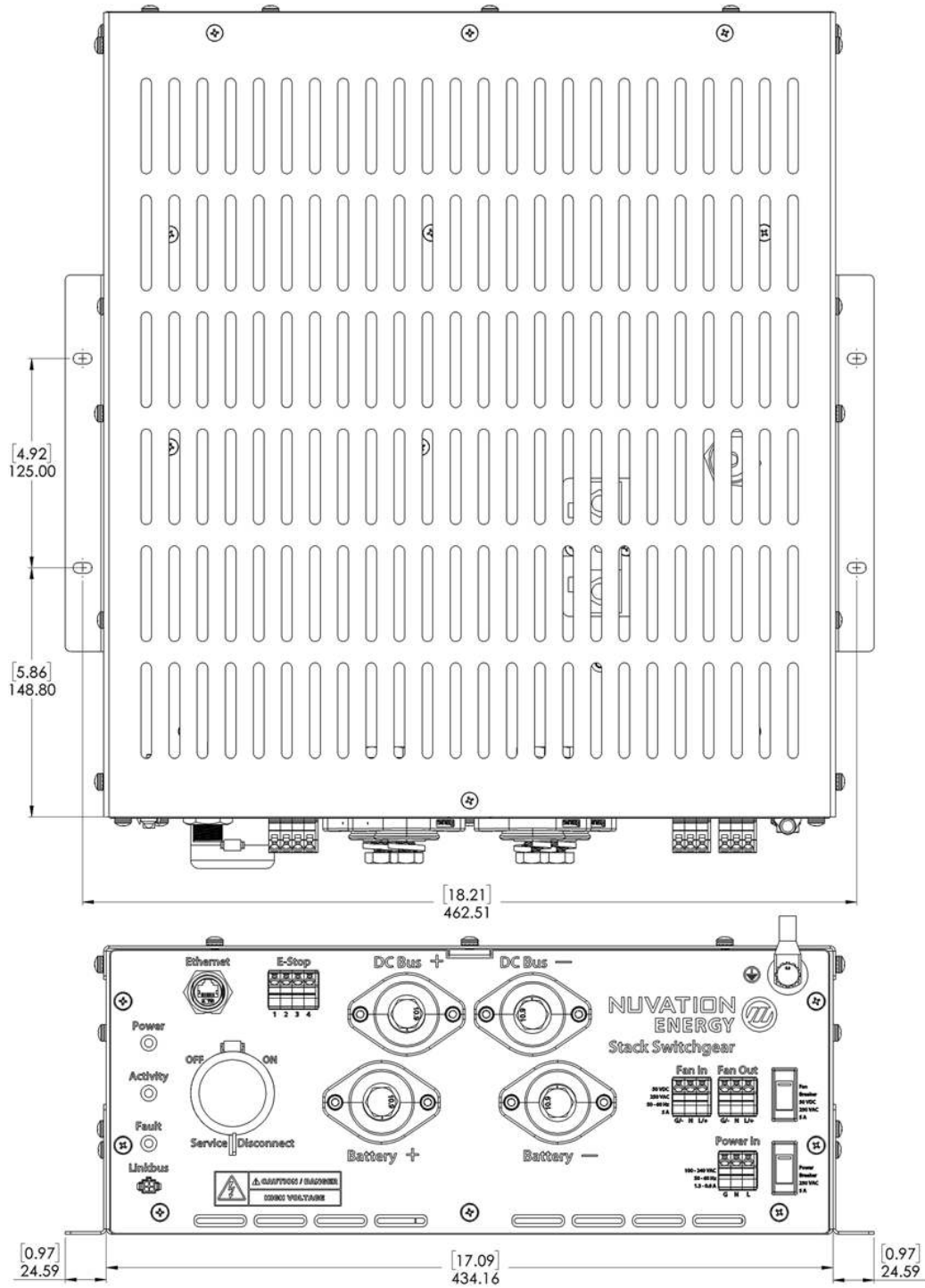

ALL DIMENSIONS IN MM [IN]

**Figure 14. Dimensions, shelf-mount**

### 3.2. Cell Interface

The overall dimensions of the Cell Interface are 104.4 mm × 121.58 mm × 40.6 mm. The standard Cell Interface (i.e. with bulkhead) weighs approximately 450 g.

The Cell Interface is available in a bulkhead-mountable enclosure as shown in [Figure 15](#). The enclosure has five metal walls, leaving the back of the unit fully exposed.

It must be mounted to a metal bulkhead panel such that the panel covers the exposed back.

The NUV100-CI-12-1 and NUV100-CI-16-1 variants produce up to 24 W and 32 W, respectively, during cell balancing. A portion of this heat is transferred to the bulkhead.

Extra space should be provided around the module to allow for easy installation/maintenance.

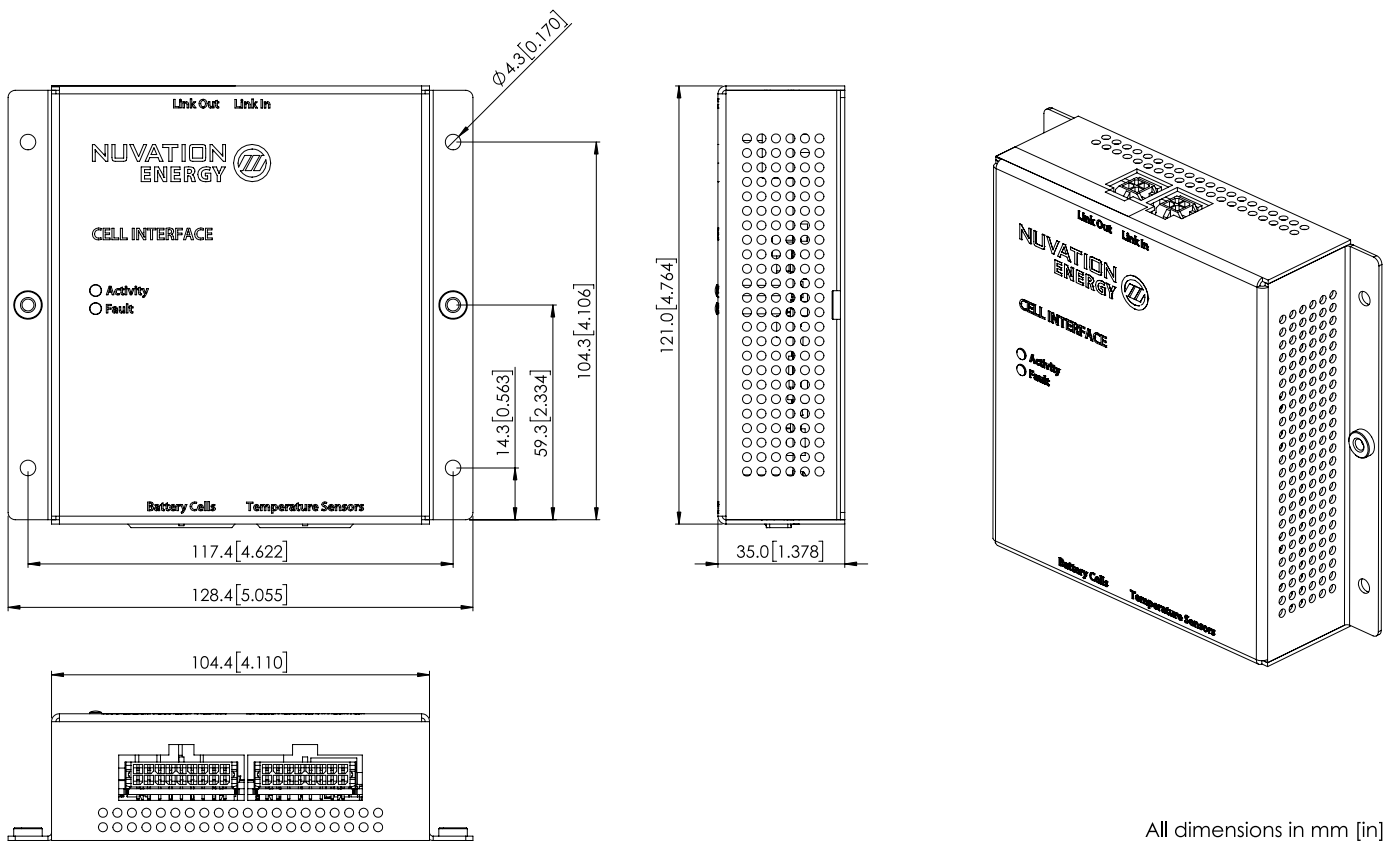

All dimensions in mm [in]

**Figure 15. Mechanical Drawing of Cell Interface with Bulkhead Enclosure**

#### 3.2.1. Optional DIN rail mounting Kit

For applications requiring DIN rail mounting, the Cell Interface may be ordered with the Cell Interface Mounting Bracket (Bulkhead-to-DIN) kit. This kit is sold separately, and includes a metal plate and the necessary hardware to securely mount the standard Cell Interface (i.e. with bulkhead enclosure) to EN50022-compliant DIN rails, as shown in [Figure 16](#).

The Mounting Bracket kit assembly adds an extra 14.2 mm to the overall width of the Cell Interface



module, bringing it from 104.4 mm to 118.6 mm. The kit assembly holds the module approximately 7 mm away from the inside lip of the DIN rail.

The Mounting Bracket offsets the Cell Interface module from the center of the DIN rail approximately 30 mm upwards as shown in [Figure 16](#).

A Cell Interface with the Mounting Bracket weighs approximately 540 g.

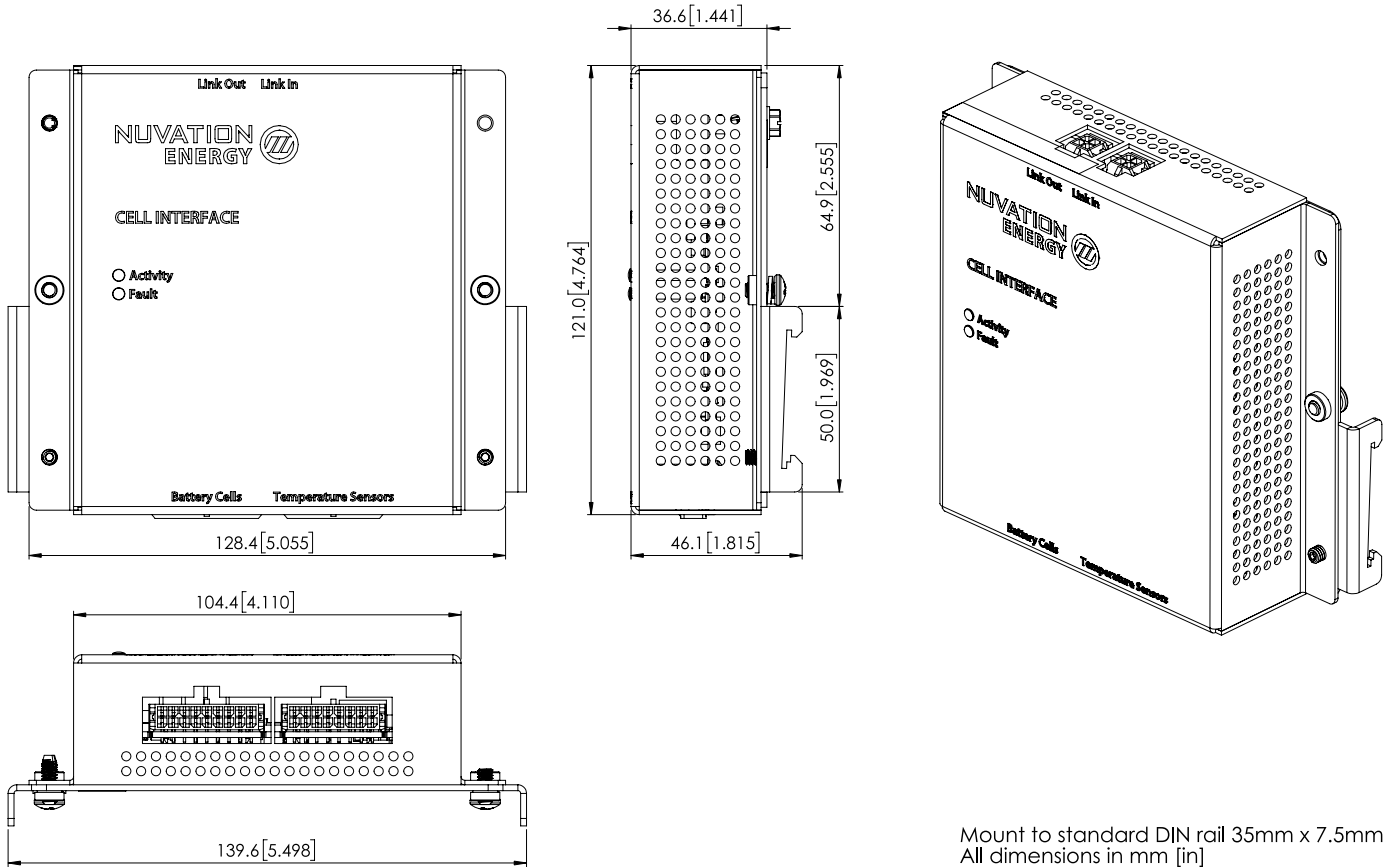

**Figure 16. Mechanical Drawing of Cell Interface with Cell Interface Mounting Bracket (Bulkhead-to-DIN)**

## 4. Ordering Information

### 4.1. Stack Switchgear

This section provides orderable part numbers for Nuvation Energy’s offerings of Stack Switchgear units and mounting accessories.

These options are suffixed to the product part number in the format: NUVSSG-1250-<current-rating>-<fuse-rating-code>.

**Table 4. Stack Switchgear Unit Ordering Information**

Part Number	Product Name	Compatible Fuse Rating
NUVSSG-1250-100-x	Stack Switchgear, 1250 V, 100 A	200 A
NUVSSG-1250-200-x	Stack Switchgear, 1250 V, 200 A	250 A, 315 A, 350 A
NUVSSG-1250-300-x	Stack Switchgear, 1250 V, 300 A	350 A, 400 A, 450 A, 500 A
NUVSSG-1250-350-x	Stack Switchgear, 1250 V, 350 A	400 A, 450 A, 500 A

\* x = fuse rating code.

#### Fuse Rating Code

The x in the product part number above denotes the fuse rating code. Refer to the table below for possible values. The Stack Switchgear fuse rating is determined by the application power profile which is based on continuous power, cycle duration, and cycle frequency. A Nuvation Energy Application Engineer will assist with determining a suitable fuse rating after an order is placed.

**Table 5. Stack Switchgear (NUVSSG-1250) fuse rating and code**

Fuse Rating	Code
200 A	1
250 A	2
315 A	3
350 A	4
400 A	5
450 A	6
500 A	7

#### Mounting Bracket

The following mounting bracket options are available. The Stack Switchgear ships with a NUVP-SSG-RB-19 by default.

**Table 6. Stack Switchgear Mounting Brackets Ordering Information**

Part Number	Product Name
NUVP-SSG-SB	Part, Stack Switchgear, Brackets for shelf-mounting
NUVP-SSG-RB-19	Part, Stack Switchgear, Front-securing Brackets for 19" Rack
NUVP-SSG-RB-19-2P	Part, Stack Switchgear, Brackets for 2-post 19" Rack



Part Number	Product Name
NUVP-SSG-RB-23-2P	Part, Stack Switchgear, Brackets for 2-post 23" Rack

To attach these brackets to the unit, fasteners (M5 x 8 mm) are included with any mounting bracket order. If fasteners other than the provided hardware is used, the screws cannot extend into the Stack Switchgear more than 8 mm. High-voltage and high-power elements that exist inside the unit could arc to the screw if it intrudes too deep into the unit.

Fasteners for attaching the brackets to the end desired surface are not provided, due to the application-specific nature. In order to source these fasteners however, note that the corresponding bracket slots have widths of 6.35 mm.

## 4.2. Cell Interface

Product part numbers for ordering a Cell Interface are listed in [Table 7](#). Accessory kits are listed in [Table 8](#).



Cell Interface kits—which include the Cell Interface module and cables—are available to get you started quickly. Please visit <https://nstore.nuvationenergy.com> for more details.

**Table 7. Cell Interface Ordering Information**

Part Number	Product Name
NUV100-CI-12-1	Cell Interface - 12 channel, Bulkhead
NUV100-CI-12-U	Cell Interface - 12 channel, PCB assembly only (no enclosure)
NUV100-CI-12-KIT	Cell Interface Kit - 12 channel
NUV100-CI-16-1	Cell Interface - 16 channel, Bulkhead
NUV100-CI-16-U	Cell Interface - 16 channel, PCB assembly only (no enclosure)
NUV100-CI-16-KIT	Cell Interface Kit - 16 channel
NUV100-CI-4M12-1	Cell Interface - 12 V 4 channel, Bulkhead
NUV100-CI-4M12-U	Cell Interface - 12 V 4 channel, PCB assembly only (no enclosure)
NUV100-CI-4M12-KIT	Cell Interface Kit - 12V 4 channel



If mounting a Cell Interface, PCB assembly only (no enclosure), note that the Cell Interface contains high-voltage signals reaching as high as 1250 V DC. Care must be taken when mounting the PCB into a metal enclosure to ensure that the metal walls remain a safe distance from the exposed conductor on the PCB. Using 1250 V DC as an example, the metal walls of the enclosure must be at least 4.2 mm from the nearest exposed conductor and must not touch the PCB or any component on the PCB, including the connector housings.

**Table 8. Cell Interface Accessory Kits Ordering Information**

Part Number	Product Name
NUVP-CI-DIN-MB	Cell Interface Mounting Bracket (Bulkhead-to-DIN)

## 5. Document Revision History

Revision	Date	Details
2.4	2021-03-04	Initial Release
2.5	2021-08-13	PCN005 updates
2.6	2021-10-08	Added compatible fuse ratings to ordering information table
2.7	2022-01-11	Updated contactor specifications
2.8	2022-04-13	Updated Cell Interface specifications
2.9	2022-05-27	Updated system overview

*From time to time Nuvation Energy will make updates to products in response to changes in available technologies, client requests, emerging energy storage standards, and other industry requirements. The product specifications in this document, therefore, are subject to change without notice.*

© 2022 Nuvation Energy