



Nuvation Energy Low-Voltage BMS

NUV300 Datasheet

Document ID: NE-DS-002 | Revision: 2.1, 2020-05-06

Table of Contents

- 1. System Overview 1
- 2. Operating Limits 3
 - 2.1. Stack Power Specification 3
 - 2.2. Battery Cells Specification 3
 - 2.3. Temperature Sensors Specification 3
 - 2.4. Contactors Coil Driver Specification 4
 - 2.5. Ethernet Specification 4
 - 2.6. Current Shunt Specification 4
 - 2.7. GPIO-Out 4
 - 2.8. GPIO-In 5
 - 2.9. RS-485 Modbus-RTU Specification 5
 - 2.10. Link Out - Expansion Interface Specification 5
 - 2.11. CAN Specification 5
- 3. Environmental Conditions 6
 - 3.1. Thermal Specification 6
 - 3.2. Humidity Specification 6
 - 3.3. Shock and Vibration Specification 6
- 4. Hardware Overview 7
 - 4.1. Power, Monitoring, and Control Connections 7
 - 4.1.1. Cell Voltage and Temperature (J8) 8
 - 4.1.2. Current Shunt and +VPOWER (J7) 8
 - 4.1.3. Contactors and -VPOWER (J6) 9
 - 4.1.4. Control GPIO (J5) 9
 - 4.2. Communication Connections 10
 - 4.2.1. Link Out (J1) 10
 - 4.2.2. Ethernet (J2) 10
 - 4.2.3. CAN (J3) 10
 - 4.2.4. RS-485 Modbus RTU (J4) 10
- 5. Cell Interface Expansion Module 11
 - 5.1. Scaling to over 16 channels 11
 - 5.1.1. Safety Considerations 12
- 6. Mechanical Overview 13
- 7. Ordering Information 14

1. System Overview

The Nuvation Energy Low-Voltage BMS is a complete battery management system that provides cell balancing and charge management for virtually any battery chemistry using a Battery Controller. The Battery Controller is designed for input voltage of 11-60 V DC. It can manage up to 12 or 16 battery cells in series, and can be expanded to manage additional cells with a Nuvation Energy Cell Interface module.

An example 12 or 16 channel configuration is shown in [Figure 1](#). This configuration requires a single Battery Controller.

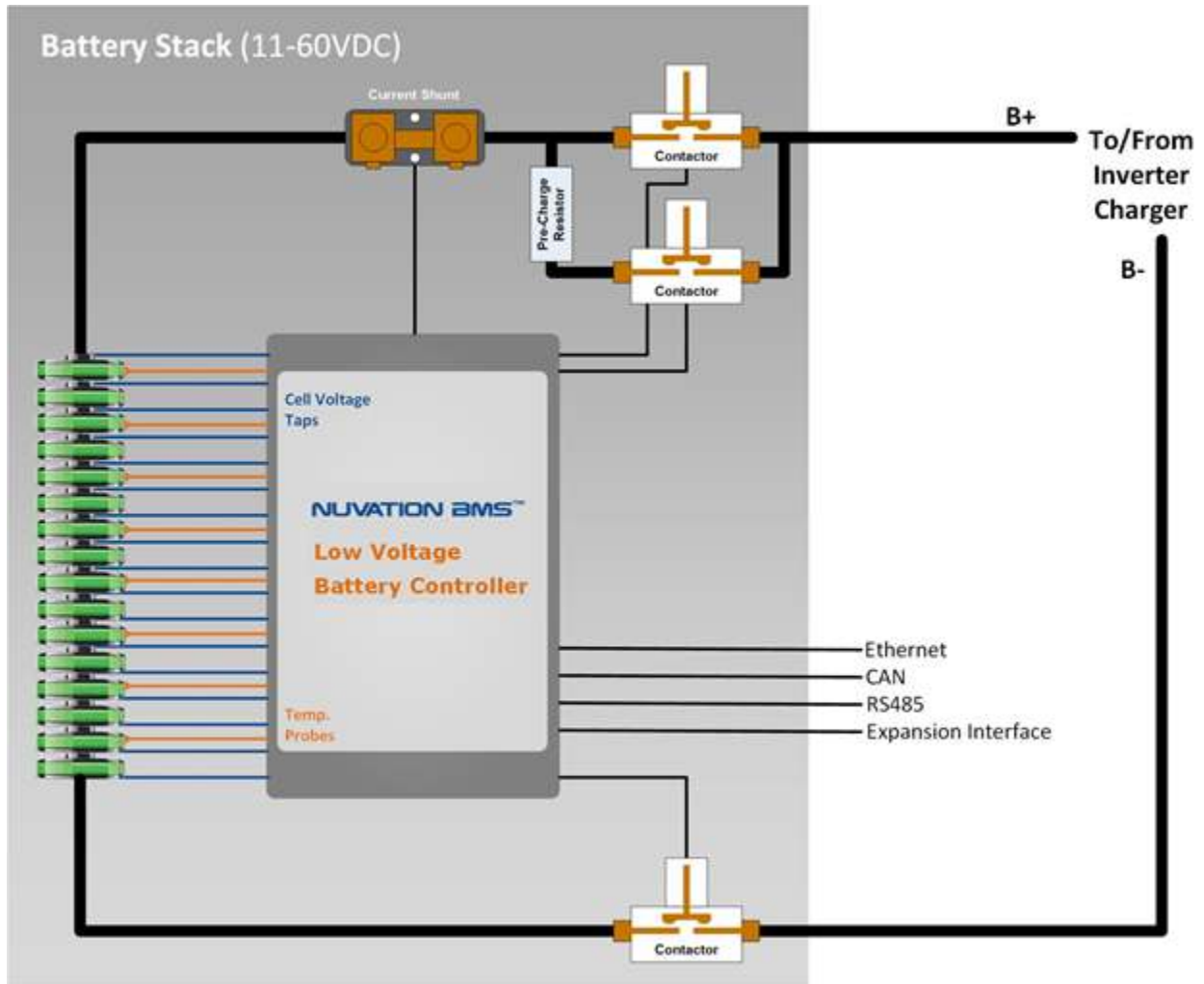

Figure 1. Nuvation Energy Low-Voltage BMS System Overview

An example 24-channel configuration is shown in [Figure 2](#). This configuration requires a Battery Controller and a Cell Interface. Please see [Section 5.1](#) for more details.

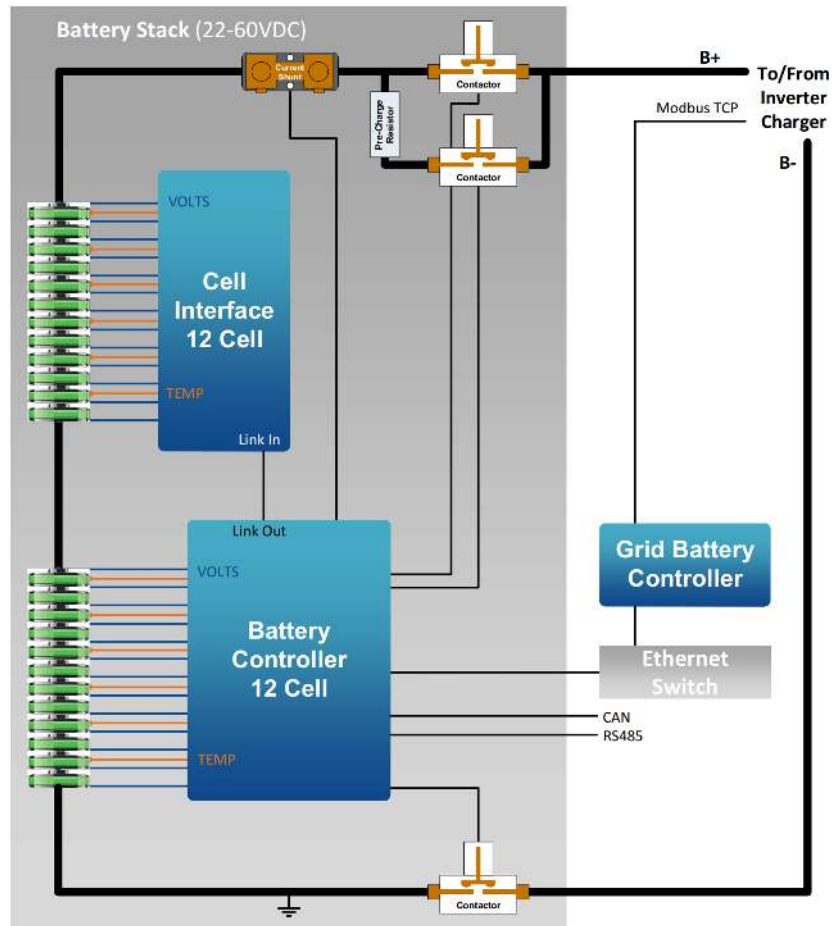

Figure 2. Low-Voltage BMS System Overview: 24-channel Application

2. Operating Limits

This section states the operating limits of the Battery Controller.



Exceeding the maximum ratings will damage the module.

2.1. Stack Power Specification

Table 1. Stack Power Specification

Symbol	Parameter	Conditions	Min	Typ	Max	Units
+VPOWER	Input DC Voltage		11	48	60	V
	Input Current	+VPOWER = 48V DC	70	580	1250	mA



While Low-Voltage BMS is designed for an input voltage of 11-60VDC, testing has confirmed that the unit experiences no degradation when using an input voltage up to 68 V DC. However, for applications that exceed 60 V DC, please consider Nuvation Energy High-Voltage BMS or contact support@nuvationenergy.com.



The +VPOWER input current depending on the loads the Low-Voltage BMS is driving. Without contactors, the Low-Voltage BMS draws approximately 70mA at 48VDC. With all contactors connected and energized, it can draw up to 1.25A at 48VDC.

2.2. Battery Cells Specification

Symbol	Parameter	Conditions	Min	Typ	Max	Units
C(n)	Input Cell Voltage Range		0	-	5	V
Vsum	Voltage between C0 and C12	BC12	11	-	60	V
	Voltage between C0 and C16	BC16	22	-	60	V
	Voltage between C0 and C8	BC16	11	-	40	V
	Voltage between C8 and C16	BC16	11	-	40	V
TME	Total Measurement Error		±0.1	±1.2	±1.6	mV
I(n)	Cell Balancing Current	C(n) = 4V	304	307	310	mA

2.3. Temperature Sensors Specification

Symbol	Parameter	Conditions	Min	Typ	Max	Units
I(n)	Output Current to Temperature Sensor		-	-	300	uA
Rt(n)	Temperature Sensor Resistance at 25C		-	10	-	kΩ
T(n)	Input Temperature Sensor Voltage Range	Cell 0 = 0V	0	-	3	V

2.4. Contactors Coil Driver Specification

Symbol	Parameter	Conditions	Min	Typ	Max	Units
+VCOIL	External Coil Power Supply Input		5	24	40	V
	External Coil Power Supply Continuous Current	+VCOIL = 24V	-	-	2.8	A
	External Coil Power Supply Pulse Current (<150ms)	+VCOIL = 24V	-	-	20	A
+24V	Output Voltage		-	24	-	V
	Output Continuous Current		-	-	1	A
	Output Pulse Current (<150ms)		-	-	2.4	A
COIL(n)	Coil Driver Output Voltage		-	+VCOIL	-	V
	Coil Driver Output Continuous Current	+VCOIL = 24V	-	-	2.8	A
	Coil Driver Output Pulse Current (<150ms)	+VCOIL = 24V	-	-	5	A
	Reverse Clamp Voltage	+VCOIL = 24V	40	-	49	V



Nuvation Energy BMS does not include an internal free-wheeling protection diode on contactor coil-driver circuits, as it has been found to cause premature contactor failure.

2.5. Ethernet Specification

Symbol	Parameter	Conditions	Min	Typ	Max	Units
ETH_Protocol	Ethernet data speeds		10	-	100	Base-T
ETH_Connector	Ethernet jack rating		-	Cat5e	-	

2.6. Current Shunt Specification

Symbol	Parameter	Conditions	Min	Typ	Max	Units
VSHUNT_REF	Reference Output Voltage		-	1.25	-	V
	Reference Output Current		-250	0	250	µA
Vdiff	Differential voltage between VSHUNT_BAT and VSHUNT_LOAD		-1.0	0	1.0	V
Vmes	Measurement resolution		-	143	-	nV

2.7. GPIO-Out

Symbol	Parameter	Conditions	Min	Typ	Max	Units
Vmax	Open Blocking Voltage	Between *_A and *_B, or between *_B and *_A	-	-	60	V

Symbol	Parameter	Conditions	Min	Typ	Max	Units
I _{max}	Closed Maximum Current	Between *_A and *_B, or between *_B and *_A	-	-	400	mA
R _{on}	Closed-State Resistance	Between *_A and *_B, or between *_B and *_A	-	-	2	Ω

2.8. GPIO-In

Symbol	Parameter	Conditions	Min	Typ	Max	Units
Turn-On	Turn On Threshold Voltage		0	-	3.8	V
	Turn-On Threshold Current		-	0.25	2	mA
Turn-Off	Turn-Off Threshold Voltage		4.8	-	5	V
	Turn-Off Threshold Current		0.1	0.2	-	mA
V _{max}	Off Voltage	I _{in} = 0mA	-	-	5	V
I _{max}	On Current	V _{in} = 0V	-	-	9	mA

2.9. RS-485 Modbus-RTU Specification

Symbol	Parameter	Conditions	Min	Typ	Max	Units
R _{term}	Termination resistance tolerance		118.8	120	121.2	Ω
	Power rating		-	-	0.125	W
V _{od}	Driver differential output		1.5	2	-	V
I _o	Output current		-60	-	60	mA
t _r	Output Signal Rise Time		0.3	0.7	1.2	μs
t _f	Output Signal Fall Time		0.3	0.7	1.2	μs
Isolation	Rated Isolation		-	-	60	V

2.10. Link Out - Expansion Interface Specification

Symbol	Parameter	Conditions	Min	Typ	Max	Units
IP_LINK	Output Current		-	-	20	mA
IN_LINK	Output Current		-	-	20	mA

2.11. CAN Specification

Symbol	Parameter	Conditions	Min	Typ	Max	Units
R _{term}	Termination resistance tolerance		118.8	120	121.2	Ω
	Power rating		-	-	0.125	W

Symbol	Parameter	Conditions	Min	Typ	Max	Units
CAN_P	Dominant Output		2.9	3.5	4.5	V
	Recessive Output		2	2.3	3	V
	Output Current		10	-	70	mA
	Output Signal Rise Time		-	20	50	ns
	Output Signal Fall Time		-	20	50	ns
CAN_N	Dominant Output		0.8	1.2	1.5	V
	Recessive Output		2	2.3	3	V
	Output Current		10	-	70	mA
	Output Signal Rise Time			20	50	Ns
	Output Signal Fall Time			20	50	Ns
Isolation	Rated Isolation		-	-	60	V

3. Environmental Conditions

3.1. Thermal Specification

Symbol	Parameter	Conditions	Min	Typ	Max	Units
Ta	Operating Temperature		-40	25	50	C
	Storage Temperature		-40	25	50	C

3.2. Humidity Specification

Symbol	Parameter	Conditions	Min	Typ	Max	Units
RH	Operational RH		5	-	85	%
	Storage RH		5	-	85	%

3.3. Shock and Vibration Specification

Symbol	Parameter	Conditions	Min	Typ	Max	Units
Vertical	Vertical shock/vibration		-	-	10	m/s ²
Longitudinal	Longitudinal shock/vibration		-	-	10	m/s ²
Transverse	Transverse shock/vibration		-	-	10	m/s ²
Pulse vibration	On each axis		-	-	245	m/s ²

The Battery Controller is designed to comply with industry EMC standards for FCC and IC Class A, and European EN55032 Class A. It is designed for EMI and ESD performance to EN55024, including the IEC/EN 61000-4-X series of tests. All components are EU RoHS/China RoHS compliant.

4. Hardware Overview

The Battery Controller contains analog-to-digital measurement circuitry which reads cell voltage, current and temperature values. It also contains processing capability and software to support decision making and allow it to operate as a stand-alone battery management system. The external interfaces to this module are:

- Cell voltage and temperature sense connector
- Current shunt connector
- 4 contactor coil driver outputs
- 4 optically isolated digital inputs
- 4 optically isolated digital outputs
- 10/100 Base-T Ethernet port (Modbus-TCP)
- Isolated CAN 2.0 port
- RS-485 (Modbus-RTU) port
- Expansion interface connector for additional Cell Interface modules
- Fault and communication indicator LEDs

The Battery Controller is available in two models:

1. The NUV300-BC-12 which can monitor up to 12 voltage channels
2. The NUV300-BC-16 which can monitor up to 16 voltage channels

These models can be expanded to monitor additional channels in certain situations. See [Section 5.1](#) for information on adding an additional Cell Interface module.

The following subsections describe the external interfaces in more detail. For wiring/pinout information, please refer to the *Nuvation Energy Low-Voltage BMS: Installation Guide*.

4.1. Power, Monitoring, and Control Connections

While the maximum input voltage to the Battery Controller will not exceed 60V, precaution should be taken to avoid any short circuits, as high current levels could present a burn and fire hazard. Note that the Battery Controller will be powered by either a Limited Power Source or an external Class 2 source; in the case it is self-powered from its own battery, you are required to provide and install a fuse in one or both power wires (+VPOWER and -VPOWER) depending on the system grounding scheme. The current rating of the fuse (I_{fuse}) must be chosen based on the peak open circuit voltage ($V_{oc,max}$) of the supply to the Battery Controller (i.e. battery stack voltage) as shown in [Table 2](#).

Table 2. Battery Controller Power Wire Fuse Selection Guide

Stack Voltage	Fuse Rating	Example Part
$V_{oc_max} < 20V, I_{fuse} = 100/20 = 5A$		
12V Battery (9-16V)	5A	Eaton P/N: BK/ABC-5-R
$20V < V_{oc_max} < 60V, I_{fuse} = 100/V_{oc_max}$		
24V Battery (18-32V)	3A	Eaton P/N: BK/ABC-3-R
36V Battery (27-48V)	2A	Eaton P/N: BK/ABC-2-R
48V Battery (36-60V)	1.5A	Eaton P/N: BK/ABC-1-1/2-R

4.1.1. Cell Voltage and Temperature (J8)

The Cell voltage and temperature sense connector (J8) is a 40-pin Samtec Mini Mate™ connector. This interface is used to connect the battery cell voltage sense wires as well as up to eight 10 kΩ NTC thermistors to the Battery Controller.

The temperature sensors are referenced to Cell 0 (the negative end of the most negative cell) so care must be taken to ensure that they remain electrically isolated from any other cell voltage terminals. These sensors are used by the Battery Controller to sense over and under temperature conditions.

This interface also provides cell voltage input and a means for balancing the cells. The cable wire should be rated for at least 750 mA to tolerate the worse-case current. Pins 39 and 40 must be connected to the negative terminal of the lowest potential cell in the module and pin 27 (or pin 23 in a NUV300-BC-16) must be connected to the positive terminal of the highest potential cell in the module. All unused voltage inputs should be tied to the next highest potential voltage sense input. In this way, all pins should be connected with the exception of pins 23, 24, 25 and 26 in a NUV300-BC-12.



A minimum of 11V must be present between Cell 0 and Cell 12 in a NUV300-BC-12, and a minimum of 11V must be present between Cell 0 and Cell 8 as well as between Cell 8 and Cell 16 in a NUV300-BC-16.

Table 3. Connector details for Cell Voltage and Temperature (J8) cable

Connector Vendor	Samtec Inc.
Series	IPL1
Circuits	40
Manufacturer Part Number	IPL1-120-01-L-D-RA1-K
Mating Cable Harness Connector Housing	IPD1-20-D or IPD1-20-D-M
Mating Cable Harness Connector Crimp Pins	CC79R-2024-01-L for 20-24 AWG

4.1.2. Current Shunt and +VPOWER (J7)

The Current shunt connector (J7) is a 6-pin Mini-Fit® Jr. Molex connector. This interface is used to connect the current shunt and, optionally, a 10 kΩ NTC thermistor to measure shunt temperature. The positive operating power for the Battery Controller (+VPOWER) is provided to this connector. You will need to supply and install a fuse according to [Table 2](#).

Table 4. Connector details for Current Shunt and +VPOWER (J7) cable

Connector Vendor	Molex Inc.
Series	Mini-Fit
Circuits	6
Manufacturer Part Number	39-30-1062
Mating Cable Harness Connector Housing	39-01-2065
Mating Cable Harness Connector Crimp Pins	39-00-0073 for 18-24AWG

4.1.3. Contactors and -VPOWER (J6)

The Contactors connector (J6) is a 12-pin Mini-Fit® Jr. Molex connector. This interface is used to drive up to 4 external contactor coils and to select their power source.

The negative operating power for the Battery Controller (-VPOWER) is provided to this connector. You will need to supply and install a fuse according to [Table 2](#).

Contactors coils receive their operating power from the connector’s +VCOIL terminal. The internal 24 V supply of the Battery Controller is available to power the coils and, in that case, each output is capable of sourcing a maximum of 1 A continuously, or a pull-in surge of up to 2.4 A. When using the internal 24 V supply of the Battery Controller to drive contactor coils, the sum of all 4 output currents must not exceed 1 A continuous or 2.4 A peak.

Alternatively, contactors may be powered from an external 5 V to 40 V DC source, as may be appropriate for the coils. In that case, each output is capable of sourcing a maximum of 2.8 A continuously, or a pull-in surge of up to 5 A. When using an external DC power source to drive contactor coils, the sum of all 4 output currents must not exceed 2.8 A continuous.

Table 5. Connector details for Contactors and -VPOWER (J6) cable

Connector Vendor	Molex Inc.
Series	Mini-Fit
Circuits	12
Manufacturer Part Number	39-30-1122
Mating Cable Harness Connector Housing	39-01-2125
Mating Cable Harness Connector Crimp Pins	39-00-0073 for 18-24AWG

4.1.4. Control GPIO (J5)

The GPIO connector is a 24-pin Samtec Mini Mate™ connector. This interface provides connections to isolated general purpose inputs and outputs, and also special function inputs that:

- Enable the BMS
- Invoke or force a system shutdown
- Clear system faults
- Invoke a factory reset

The functionalities of the general purpose inputs and outputs are configurable by the end-user to match their needs.

Table 6. Connector details for Control GPIO (J5) cable

Connector Vendor	Samtec Inc.
Series	IPL1
Circuits	24
Manufacturer Part Number	IPL1-112-01-L-D-RA-K
Mating Cable Harness Connector Housing	IPD1-12-D or IPD1-12-D-M
Mating Cable Harness Connector Crimp Pins	CC79R-2024-01-L for 20-24 AWG

4.2. Communication Connections

4.2.1. Link Out (J1)

The Link Out interface connector is a standard Cat5e RJ45 jack. This interface is used to connect the Battery Controller module to an expansion Cell Interface module. See [Section 5.1](#) for more details on expansions using a Cell Interface.

A green LED on the interface connector jack indicates link activity.

4.2.2. Ethernet (J2)

The Ethernet jack is a standard Cat5e RJ45 jack. This interface is used as the primary means of connecting an external system to the Battery Controller to configure the operating parameters, observe the status, and perform maintenance such as firmware upgrades. It provides an interface that an external controller may use to read and write registers in order to make decisions regarding the overall system.

Two LEDs on the Ethernet jack indicate link status (green LED) and network activity (yellow LED).

4.2.3. CAN (J3)

The CAN connector is a standard Cat5e RJ45 jack. This interface provides an isolated CAN 2.0 port. It provides an interface that an external controller may use to read and write registers in order to make decisions regarding the overall system.

Jumper-selectable resistive bus termination is available upon request. A green LED on the CAN connector indicates CAN bus activity.

4.2.4. RS-485 Modbus RTU (J4)

The RS-485 connector is a standard Cat5e RJ45 jack. This interface provides an isolated RS-485 (Modbus-RTU) port. It provides an interface that an external controller may use to read and write registers in order to make decisions regarding the overall system.

Jumper-selectable resistive bus termination is available upon request. A green LED on the RS-485 connector indicates Modbus activity.

5. Cell Interface Expansion Module

5.1. Scaling to over 16 channels

A Nuvation Energy Cell Interface may be used as an expansion module on Low-Voltage BMS systems which are less than 60 V, but have more cells than supported by the base Battery Controller module (i.e. 16 cells).

For example, on a 24 cell system of 2V lead-acid cells (total stack of 48 V), a 12-channel Battery Controller and 12-channel Cell Interface may be used to manage the 24 cells.

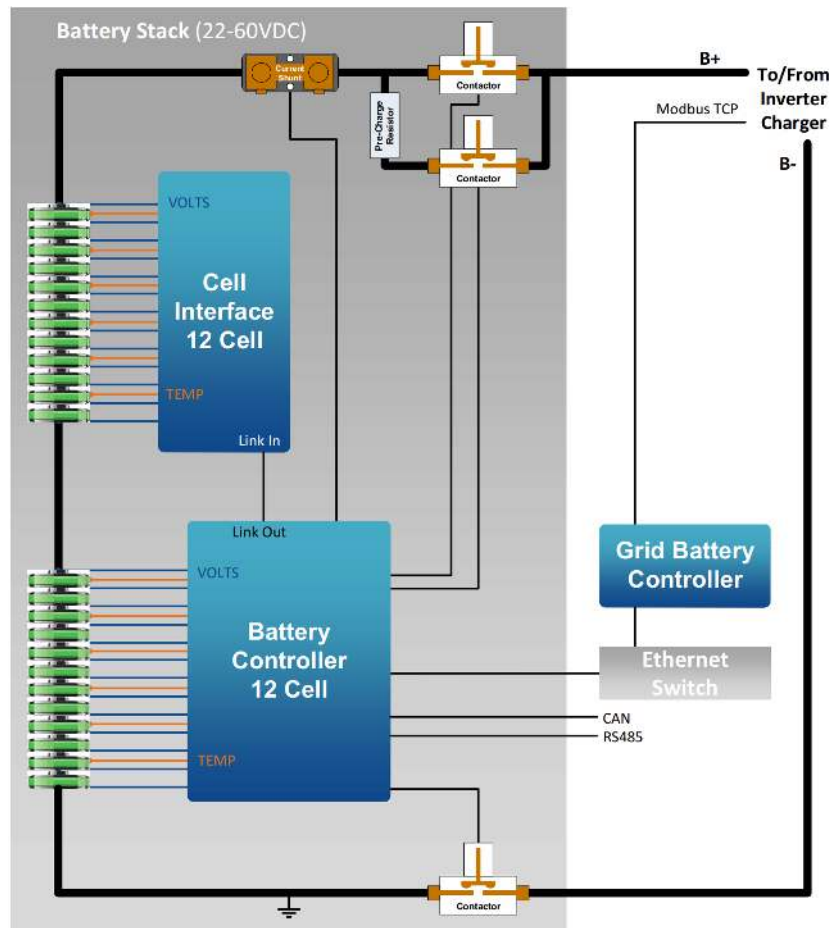

Figure 3. Low-Voltage BMS System Overview: 24-channel Application



The Nuvation Energy Low-Voltage Battery Controller system should not be used with a battery stack that exceeds 60 V DC during normal operation.

Please see [Section 5.1.1](#) below for safety considerations.

The Cell Interface connects to the battery cells and temperature sensors. It monitors and balances the cells, sends cell data to the Battery Controller, and prevents overheating or overcharging of cells.

[Table 7](#) below shows the available Cell Interface configurations and the corresponding Battery

Controller configurations which support them.

Table 7. Supported Cell Interface to Battery Controller system pairings

Cell Interface	Supported Battery Controller
Cell Interface - 12 channel	Battery Controller - 12 channel
Cell Interface - 16 channel	Battery Controller - 16 channel
Cell Interface - 12V 4 channel	Not supported



Nuvation Energy Cell Interface datasheet is available online at <https://www.nuvationenergy.com/technical-resources>.

5.1.1. Safety Considerations

The Battery Controller’s I/O ports (Ethernet, CAN, RS485, GPIO, Link Out) are SELV (Safety Extra Low Voltage) rated to 60 V. For example, a system using more than 16 cells of 2V lead-acid could exceed the 60 V maximum of the Battery Controller module during the equalization phase of the charge profile.

To maintain the SELV rating of the Battery Controller I/O ports, the negative terminal of the battery stack must be connected to earth ground. This prevents high voltage from propagating out of the I/O ports in the very unlikely event of an internal failure with the current shunt interface. This requirement also means that any device connected to the Battery Controller must reference its signals to earth ground, as any signal referenced to the top of the battery stack would exceed the 60 V limit of the Battery Controller.

6. Mechanical Overview

The overall dimensions of the Battery Controller are 220 mm X 125 mm X 30 mm. Extra space should be provided around the module to allow for easy installation/maintenance.



Dimensions in the diagram below are shown in inches

The Battery Controller should be securely mounted in a vertical orientation, in an environment that permits free movement of air through all ventilation slots for convection cooling. The Cell Connections connector (J1) should be facing up or to the left. If it is to be used with a battery chemistry such as lead-acid, which does not require balancing, the Battery Controller may be mounted horizontally, with the ventilation slots oriented upwards. It is not advisable to mount the Battery Controller on the underside of a horizontal surface.

The Low-Voltage Battery Controller weighs approximately 400 g.

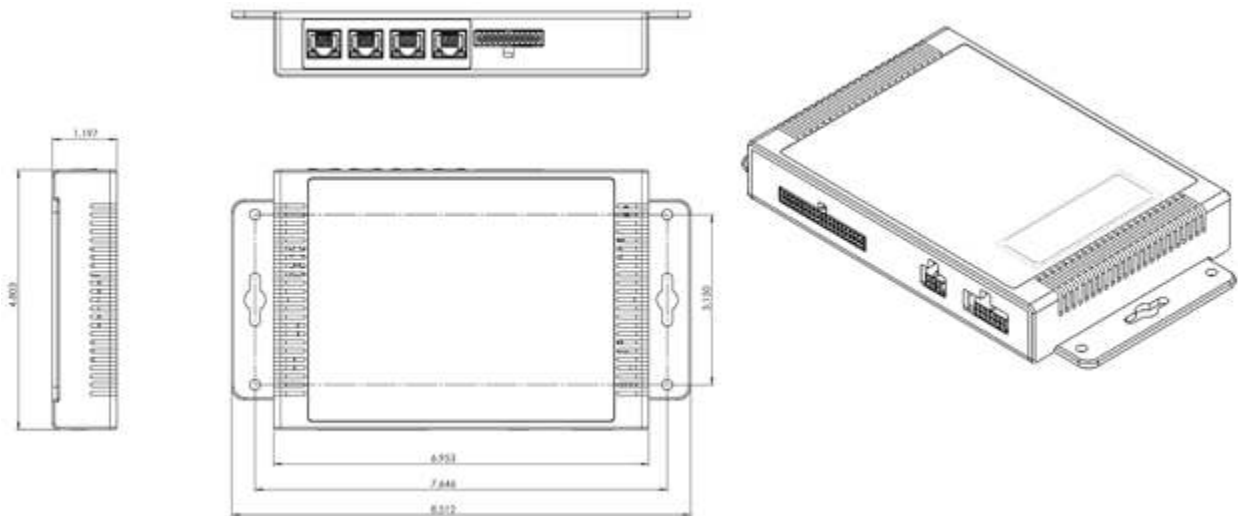

Figure 4. Mechanical Drawing of Battery Controller

7. Ordering Information

Model Number	Description
NUV300-BC-12-P	Low-Voltage Battery Controller - 12 channel
NUV300-BC-12-U	Low-Voltage Battery Controller - 12 channel, PCB assembly only (no enclosure)
NUV300-BC-12-CSK	Low-Voltage Battery Controller - 12 channel Starter Kit (see note below)
NUV300-BC-16-P	Low-Voltage Battery Controller - 16 channel
NUV300-BC-16-U	Low-Voltage Battery Controller - 16 channel, PCB assembly only (no enclosure)
NUV300-BC-16-CSK	Low-Voltage Battery Controller - 16 channel Starter Kit (see note below)
<i>Expansion Module</i>	Please refer to <i>Nuvation Energy Cell Interface: NUV100-CI Datasheet</i> , available at: https://www.nuvationenergy.com/technical-resources

Customer Starter Kits



A Customer Starter Kit includes the Battery Controller module with enclosure and a cable kit to get you started.

Please visit <https://nstore.nuvationenergy.com> for more details.

From time to time Nuvation Energy will make updates to Nuvation Energy BMS in response to changes in available technologies, client requests, emerging energy storage standards, and other industry requirements. The product specifications in this document, therefore, are subject to change without notice.

© 2020 Nuvation Energy