



Nuvation Energy G5 High-Voltage BMS

NUVG5 Product Manual

Document ID: NE-PM-011 | Revision: 1.7, 2024-07-26

BMS Software Version: Faraday Update 1
© 2024 Nuvation Energy

Table of Contents

1. Introduction	2
1.1. About this Manual	2
2. Product Overview	3
2.1. Functional Overview	5
2.2. G5 Stack Switchgear	7
2.3. G5 Cell Interface	9
2.4. G5 BMS Software	10
2.4.1. Operator Interface	10
2.4.2. G5 BMS Firmware	10
3. Installation Instructions	12
3.1. Quick Start Guide	12
3.2. G5 Cell Interface	13
3.2.1. Installation Overview	13
3.2.2. Mechanical Installation	14
3.2.2.1. Dimensions and Weight	14
3.2.2.2. Installation Location and Position	14
3.2.2.3. Mounting Instructions	15
3.2.3. Electrical Connections	16
3.2.3.1. Getting Started	16
3.2.3.2. Connect the Voltage and Temperature Sensors Cable	17
3.2.3.3. Connect the Link Bus Cable	21
3.3. G5 Stack Switchgear	23
3.3.1. Installation Overview	23
3.3.2. Mechanical Installation	24
3.3.2.1. Dimensions and Weight	24
3.3.2.2. Installation Location and Position	25
3.3.2.3. Mounting Instructions	25
3.3.3. Electrical Connections	30
3.3.3.1. Getting Started	30
3.3.3.2. Ensure system is de-energized	32
3.3.3.3. Ground the G5 Stack Switchgear	32
3.3.3.4. Connect Power In and Fan Control	33
3.3.3.5. AC Fan Breaker and DC Fan Overload Protection	35
3.3.3.6. Connect control to General Purpose Input/Output (GPIO) cable	36
3.3.3.7. Connect Ethernet cable to external computer	37
3.3.3.8. Connect Link Out cable to G5 Cell Interface	38
3.3.3.9. Set the Config Switches	39
3.3.3.10. Connect Battery Stack and DC Bus	41
3.4. First Power-up	44
3.5. Operator Interface Installation	45
3.5.1. Download and Install	45
3.5.2. Setup PC Network Adapter	45

- 3.5.3. Launch Operator Interface 47
- 3.6. Calibrate Nuvation Energy BMS 49
- 4. Configuration Settings 50
 - 4.1. Using Configuration Files 50
 - 4.1.1. Generate Configuration File 50
 - 4.1.2. Import the Configuration File 50
 - 4.1.2.1. Configuration File Import Troubleshooting 51
 - 4.2. Background and Terminology 52
 - 4.2.1. Register Data Model 52
 - 4.2.1.1. Index versus Location 52
 - 4.2.1.2. Register Expressions 53
 - 4.2.2. Units 55
 - 4.2.3. Storage Types 57
 - 4.2.4. Configuration File 57
 - 4.3. Factory Lockdown 58
 - 4.3.1. Configuring Factory Registers 58
 - 4.3.2. Enabling Factory Lockdown 58
 - 4.3.3. Clearing Factory Lockdown 58
 - 4.3.4. Restricted Register Write Operations 59
 - 4.4. Battery Parameters 60
 - 4.4.1. Stack Capacity 60
 - 4.4.2. Stack Cycle Count 61
 - 4.4.3. State-of-Health 61
 - 4.4.4. State of Charge (SoC) 61
 - 4.4.4.1. Battery Empty Condition 62
 - 4.4.4.2. Battery Full Condition 63
 - 4.4.5. Open Circuit Voltage Curve 64
 - 4.4.6. Cell Resistance Estimation 64
 - 4.4.7. Nameplate Information 64
 - 4.5. Stack Topology 65
 - 4.5.1. Cell Inputs 65
 - 4.5.2. Thermistor Inputs 66
 - 4.6. Operational Limits 66
 - 4.6.1. Triggers 67
 - 4.6.1.1. Basic Triggers 68
 - 4.6.1.2. Boolean Triggers and Standalone Triggers 68
 - 4.6.1.3. Hysteresis Triggers 68
 - 4.6.1.4. User-Defined Triggers 69
 - 4.6.1.5. Externally Activated Fault and Warning 69
 - 4.6.2. Cell Voltage Thresholds 69
 - 4.6.3. Thermistor Temperature Thresholds 71
 - 4.6.4. Stack Current Thresholds 74
 - 4.6.5. Stack Voltage Thresholds 76
 - 4.6.6. External Controller Heartbeat 79

4.7. Control Settings	79
4.7.1. Current Control	79
4.7.1.1. Stack Switch Functions	79
4.7.2. Contactor Configuration	83
4.7.2.1. Contactor Configuration	83
4.7.3. Current Limits	84
4.7.3.1. Current Limit Behavior	85
4.7.3.2. Current Limit Configuration	85
4.7.4. Passive Cell Balancing	87
4.7.4.1. Voltage Based Cell Balancing	87
4.7.4.2. Cell Balancing Duty Cycle	89
4.7.5. Continuous Balancing	89
4.7.5.1. Frequency of Continuous Balancing	90
4.7.5.2. Cell Imbalance Estimation Components	91
4.7.5.3. Cell Imbalance Estimations Configuration	91
4.7.5.4. Cell Imbalance Estimations Status	92
4.7.5.5. Continuous Balancing Configuration	92
4.7.5.6. Balancing Counters per Cell	93
4.7.5.7. Thermal Throttling for Cell Balancing	93
4.7.6. Fan Control (AC/DC)	94
4.7.6.1. Temperature Based Fan Control	94
4.7.6.2. Manual Fan Control	95
4.7.6.3. DC Fan Warning	96
4.8. Input / Output Assignment	96
4.8.1. General Purpose Digital Outputs	96
4.8.2. General Purpose Digital Inputs	97
4.8.3. Disconnect Input	98
4.8.3.1. Configuration	99
4.8.3.2. Quick Disconnect	99
4.8.4. UVLO Enable Config Switch Input	99
4.8.5. Network Reset and Factory Restore Config Switch Inputs	99
4.8.5.1. Network Reset Switch	100
4.8.5.2. Factory Restore Config Switch	101
4.8.6. Shutdown Input	101
4.8.7. Enable Input	101
4.9. External Communication Interface Settings	101
4.10. Measurement Calibration	102
4.10.1. Thermistor Calibration	102
4.10.2. Stack Current Calibration	103
4.10.2.1. Stack Current Field Calibration	103
4.10.2.2. DC Bus Current Field Calibration	104
4.10.2.3. Charge Deadband Setting	105
4.10.3. Stack Voltage Calibration	105
4.10.3.1. Stack Voltage Field Calibration	105

4.10.3.2. DC Bus Voltage Field Calibration	106
4.11. Hardware Settings	106
4.11.1. Link Bus Scan Period	106
4.11.2. Cell Voltage Low-Pass Filter	107
4.11.3. Cell Open Wire Detection and Diagnostics	107
4.11.4. Fault Pilot	108
4.11.5. Under-Voltage Lockout	109
4.11.5.1. Configuration	109
4.11.6. Clock Verification	110
4.11.7. Shorted Shunt Detection	110
4.11.8. Temperature Consistency Check	111
4.11.8.1. Recommendation for Temperature Consistency Check	112
4.11.9. Contactor Life Tracking	113
4.12. Watchdogs and Freshness	115
4.12.1. Freshness	115
5. Operating Instructions	119
5.1. Operating Limits	119
5.1.1. G5 Stack Switchgear	119
5.1.1.1. External Specifications	119
5.1.1.2. Electrical Characteristics	119
5.1.2. G5 Cell Interface	123
5.1.2.1. Electrical Characteristics	123
5.1.2.2. Maximum Stack Deployment	124
5.1.3. Environmental Conditions	124
5.2. Status LEDs	126
5.2.1. G5 Stack Switchgear Status LEDs	126
5.2.1.1. Determining BMS State from LED Status	127
5.3. Using the Operator Interface	129
5.3.1. The Dashboard Tab	129
5.3.1.1. Warnings and Faults	130
5.3.1.2. Stack Voltage	130
5.3.1.3. Stack Current	131
5.3.1.4. State-of-Charge	131
5.3.1.5. Depth-of-Discharge	131
5.3.1.6. Cell Voltage	132
5.3.1.7. Temperature	133
5.3.1.8. Nuvation Energy BMS Status	134
5.3.2. The Details Tab	137
5.3.2.1. Battery	137
5.3.2.2. Contactor Life	138
5.3.2.3. SoC Calibration	138
5.3.2.4. Safety	139
5.3.2.5. Cell Voltages	140
5.3.2.6. Thermistor Temperatures	141

5.3.2.7. Open Wire	142
5.3.2.8. Resistance	143
5.3.3. The Menu Options	145
5.3.3.1. Registers	145
5.3.3.2. Service	145
5.3.3.3. Connection	148
5.3.3.4. Locking and Unlocking	148
5.3.3.5. About	149
5.3.4. The Status Banner	151
5.3.4.1. Service Lockout Indication	151
5.3.4.2. Self Check Indication	151
5.3.4.3. Communication Loss	151
5.3.5. Understanding the Service Lockout and Self Check	152
5.3.5.1. Entering Service Lockout	152
5.3.5.2. Exiting Service Lockout	153
5.3.5.3. Self Check	154
5.3.5.4. Self Check Troubleshooting	154
5.4. Communication Protocols	155
5.4.1. Modbus Protocol Support	155
5.4.1.1. Modbus TCP	155
5.4.1.2. Implemented SunSpec Energy Storage Models	155
5.4.1.3. SunSpec Energy Storage Models Structure and Nomenclature	156
5.4.1.4. Operational Cases for SunSpec Modbus Interface	158
5.4.1.5. Configurable Modbus	162
5.4.1.6. Accessing SunSpec Energy Storage Models	165
5.5. Fault/Warning/User Trigger Bitfields	167
5.5.1. Fault Bit Mapping for Faraday Update 1	168
5.5.2. Warning Bit Mapping for Faraday Update 1	170
5.5.3. User Trigger Bit Mapping for Faraday Update 1	171
6. Preventative Maintenance	173
6.1. Battery Connections	173
6.2. Internal Temperature	173
6.3. Contactor Life	174
6.4. Enclosure Condition	174
6.5. Periodic SoC Recalibration	174
7. Preparing for Battery Stack Servicing	176
7.1. Disconnect Stack	176
7.2. Connect Stack	176
8. Troubleshooting	178
8.1. Faults and Self Check Failures	178
8.1.1. Cell Voltage Faults	178
8.1.1.1. Self Check Issues	179
8.1.2. Stack Voltage Faults	179
8.1.2.1. Self Check Issues	180

8.1.3. Thermal Faults	180
8.1.3.1. Self Check Issues	181
8.1.4. Stack Current Faults	181
8.1.4.1. Self Check Issues	181
8.1.5. Pre-charge Faults	181
8.1.5.1. Self Check Issues	182
8.1.6. Contactor Faults	182
8.1.7. AFE Related Faults	182
8.1.7.1. AFE BIST Faults	182
8.1.7.2. Self Check Issues	184
8.1.8. External Stack Switchgear Faults	184
8.1.8.1. Self Check Issues	185
8.1.9. CI Faults	185
8.1.9.1. Known Issues	185
8.1.9.2. Self Check Issues	186
8.1.10. DC Fans	186
8.1.10.1. Self Check Issues	186
8.1.11. Watchdog Faults	186
8.1.11.1. Self Check Issues	187
8.1.12. Configuration Faults	188
8.1.13. Functional Safety Faults	188
8.1.13.1. Self Check Issues	190
8.2. Lost/Forgotten IP Address	190
8.2.1. Wireshark (Windows/Linux)	190
8.2.2. Netdiscover (Linux only)	191
8.3. ModbusTCP Latency	191
8.3.1. Known Issue	191
8.4. Disconnect Input Causing Faults to Trip	191
Appendix A: Ordering Information	193
G5 Stack Switchgear	193
Fuse Rating Code	193
G5 Cell Interface	194
Appendix B: Mating Connectors	195
G5 Stack Switchgear Connectors	195
Power and Fan Connector	195
I/O Connector	195
General Purpose Output	197
General Purpose Input	197
Disconnect Input	197
Enable Input	198
Shutdown Input	199
Multi-Stack Chain Pin Assignments:::	199
Linkbus Connector	200
Ethernet Connector	201

- Battery and DC Bus High Current Connectors 201
- Earth Bonding Connector 201
- G5 Cell Interface Connectors 202
 - Cell Voltage and Temperature Connector 202
 - Link In Connector 203
 - Link Out Connector 204
- Appendix C: Battery Topology Terminology 204
- Appendix D: Best Practices 206
 - Excess Cable Management. 206
 - Security 206
 - Physical Security 207
 - Network Security 207
 - Inbound Protocols and Ports 208
 - Outbound Protocols 209
 - Operator Interface Unlock Password. 209
- Appendix E: BMS Network Configuration. 210
 - Modifying the Network Settings 210
- Registers 212

The content in this document must be followed in order to ensure safe operation of Nuvation Energy BMS.



The G5 High-Voltage BMS is to be installed in a location with restricted access. Only **skilled persons** may install or service a system containing hazardous voltages that may be present when the system is energized.



Do **NOT** energize the system until all connections to the G5 Stack Switchgear unit and G5 Cell Interface modules have been made.



The wiring of the battery cell voltage and temperature sensing should be verified **before** connecting to the G5 Cell Interface modules. The temperature sensing must be isolated from the cell voltage sensing and Earth. Wiring errors can cause damage to the G5 Cell Interface and/or the cells.



Properly insulate or remove any unused wires. Unused wires can couple excessive system noise into Nuvation Energy BMS which can disrupt communication and lead to undesirable behaviors.



Nuvation Energy BMS relies on your system charger to charge the battery cells; do not leave your charger off while Nuvation Energy BMS is powered from the stack for prolonged periods of time. Nuvation Energy BMS should be shut down when the system is in storage to minimize the drain on the cells.



Insulated handling is required of any connector carrying potentials over 60 V DC relative to chassis.



Please be aware of high voltages present in your system and follow all necessary safety precautions.



The provided module enclosures are not fire enclosures.

1. Introduction

Thank you for choosing Nuvation Energy.

Designed specifically for lithium-ion battery chemistries, the Nuvation Energy new fifth-generation Battery Management System supports up to 1500 V DC battery stacks and modules that use cells in the 1.6 V - 4.3 V range. The G5 High-Voltage BMS offers cutting edge features such as continuous cell balancing and the ability to manage 24 battery cells with each series connected G5 Cell Interface module.

1.1. About this Manual

This *Nuvation Energy G5 High-Voltage BMS: NUVG5 Product Manual* is a comprehensive manual, providing:

- Details about all the features offered by your Nuvation Energy G5 High-Voltage BMS
- Mounting and wiring instructions to install this product safely
- Guidance on integrating the device into your Energy Storage System
- Guidance on operating the Nuvation Energy BMS Operator Interface



This document applies to Nuvation Energy BMS Faraday Update 1 software release (Firmware version 5.8.0, Operator Interface version 1.5.0). Content may be inaccurate or incomplete for other versions.



We thrive on your feedback and what we build is driven by your input. Please submit support tickets to support@nuvationenergy.com.

2. Product Overview

The Nuvation Energy G5 High-Voltage BMS provides cell-level and stack-level control for battery stacks up to 1500 VDC and modules that use cells in the 1.6 V - 4.3 V range. The G5 Stack Switchgear and G5 Cell Interface modules operate together as a complete system called the G5 High-Voltage BMS.



Figure 1. G5 High-Voltage BMS.

Both Nuvation Energy G5 Stack Switchgear and G5 Cell Interface are designed to enable UL 1973 certification of the battery stack. The UL 1973 Recognized Nuvation Energy BMS in each stack ensures safe battery operation and significantly reduces the effort of certifying the Energy Storage System to meet UL 1973 and UL 9540.

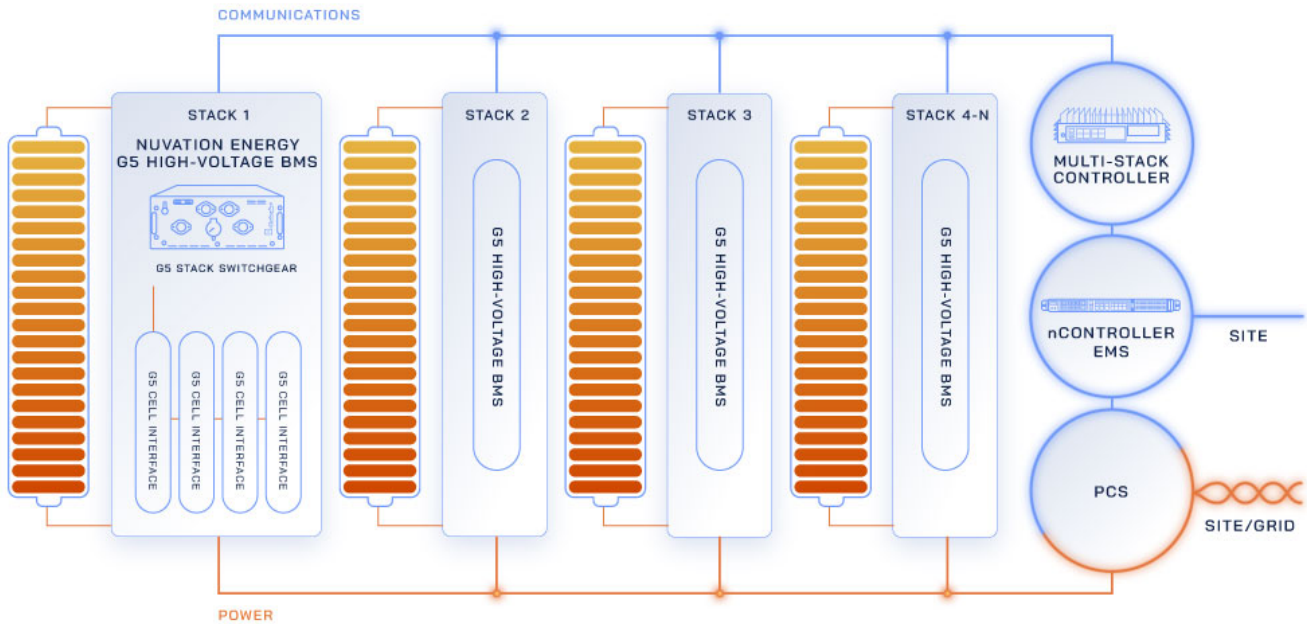

Figure 2. Sample ESS Application

Single Stack

Typically, a single battery stack requires one G5 Stack Switchgear and one or more G5 Cell Interface modules.

The Nuvation Energy G5 Stack Switchgear unit manages a single battery stack and connects it to

the DC bus of the energy storage system. The G5 Stack Switchgear is a pre-configured assembly that incorporates the major functions of Nuvation Energy G5 High-Voltage BMS into a rack-mountable unit which includes stack monitoring, electrical disconnects, pre-charging, current sensing, fuses, and fan control.

The Nuvation Energy G5 Cell Interface modules in each stack connect directly to battery cells to measure cell voltages and temperatures and provide cell balancing.

Multi-stack

In a multi-stack G5 High-Voltage BMS configuration, as shown below, each G5 Stack Switchgear unit is responsible for monitoring the state and safety of one battery stack. All G5 Stack Switchgear units connected to a single common DC bus in the system may be managed by a single Nuvation Energy Multi-Stack Controller and operated via the Nuvation Energy Operator Interface. The Operator Interface GUI provides a unified view and central control of multi-stack system.

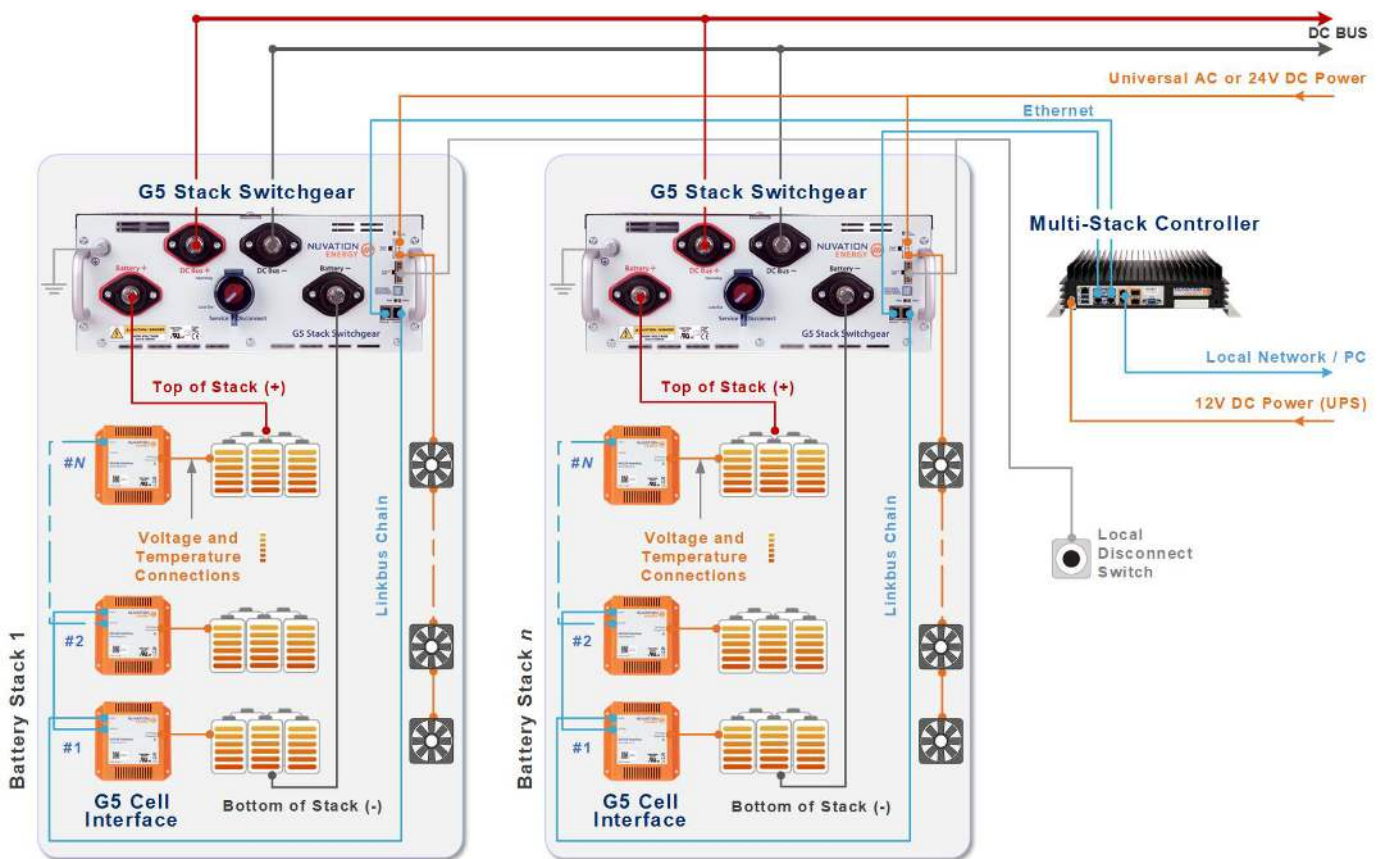

Figure 3. G5 High-Voltage BMS multi-stack diagram

2.1. Functional Overview

The Nuvation Energy G5 High-Voltage BMS provides many functions to allow flexible and configurable management and control of a stack. The following sections provide a brief summary of the product functions.

Monitor DC Bus and Stack Voltages

The G5 Stack Switchgear measures both the DC Bus and the battery stack voltages. These measurements allow for improved pre-charge and multi-stack capability.

Configurable for Different Battery Chemistries

The G5 Cell Interface is capable of measuring cells which vary in voltage between 1.6 and 4.3 volts. This range of voltage can support many lithium and lead-acid cell chemistries. A maximum of 480 cells can be measured by using a maximum of 20 G5 Cell Interface modules connected to one G5 Stack Switchgear.

Configurable Safe Limits of a Stack

As part of a UL 1973 certification, the safe operational range of a stack must be enforced by the G5 Stack Switchgear. A factory configuration is used to provide the initial safety configuration and is used within the certification process. Nuvation Energy provides a safety manual to guide the process of how to configure a stack for certification review. Once a safety configuration is established, the factory configuration can be locked to prevent further modification.

User Configurable Operational Range

After a stack is deployed, a user may choose to further limit the operational range of a stack. For example the PCS may require a minimum voltage that is higher than the stack's minimum voltage. For cases such as this, the G5 Stack Switchgear has a user configurable set of operational limits that can be set to meet these additional constraints. These configurations can be persisted into non-volatile storage and write protected with a password. A short list of these operational limits include:

- High and Low Cell Voltage
- High and Low Stack Voltage
- High Charge Current and High Discharge Current
- High and Low Cell Temperature

GPI/GPO Interfaces

Two GPIs and two GPOs are available to allow interfacing with external connections such as:

- PCS emergency OFF
- External indicator LEDs
- Ground Fault Detector Input
- Manual clear faults
- DC-OK

Internal Temperature Monitoring

The G5 Stack Switchgear has seven internal thermal measurements which are connected to a

warning/fault. Likewise, each G5 Cell Interface module monitors its internal temperature and reduces passive balancing at high temperatures.

Dedicated Enable, Shutdown, and Disconnect inputs

The G5 Stack Switchgear provides separate Enable, Shutdown, and Disconnected inputs. These inputs allow for external control to power on the Battery Management System, gracefully shutdown the Battery Management System, or safely open the contactors to disconnect the battery stack.

External Fan Control

The G5 Stack Switchgear can be used to control external AC or DC fans for cooling the battery cells. The fans are enabled by the Battery Management System when battery cell temperatures exceed configurable thresholds. There is also a manual control configuration to allow external control of the fans via software command.

Cell Open Wire Detection and Diagnostics

The G5 Stack Switchgear is capable of detecting wiring and circuit problems on each cell voltage channel. The following scenarios are detectable:

- Open circuits
- Short circuits
- High impedance connections/wiring
- Internal Battery Management System hardware failures

SunSpec Modbus TCP with Configurable Points

The G5 Stack Switchgear provides SunSpec Energy Storage Models (Draft 3) 801/802/803 data models over its Modbus TCP port. Furthermore, the device can be configured to map internal data registers to a reserved set of Modbus points. This functionality allows internal data that is not within SunSpec data models to be accessed over Modbus TCP.

Continuous Balancing

The G5 Stack Switchgear implements a balancing algorithm that estimates charge imbalances of the stack cells and applies balancing to these imbalanced cells during operation. The use of continuous balancing significantly increases operational time of the battery system managed by the Nuvation Energy BMS by decreasing the maintenance time to balance cells within the stack.

Pre-Charge Circuit

The G5 Stack Switchgear has a pre-charge circuit to ensure safe connection of its battery stack to the DC bus. The pre-charge circuit temporarily connects the stack to the DC bus through a power resistor. This resistor allows a smaller current (proportional to the difference in voltage between the stack and the DC bus) to flow between the stack and the DC bus. After a 5-second pre-charge timeout, if the measured current is below a safe threshold, the BMS bypasses the pre-charge circuit by connecting the stack directly to the DC bus. This ensures the battery stack will not connect to the DC bus when an unsafe voltage mismatch is present. The G5 Stack Switchgear includes a 150 Ω , 210 W power resistor, suitable for a DC bus capacitance up to 8.5 mF at 1500 V DC.

2.2. G5 Stack Switchgear

The following variants of the Nuvation Energy G5 Stack Switchgear are available:

- G5 Stack Switchgear, 1500 V, 200 A
- G5 Stack Switchgear, 1500 V, 300 A
- G5 Stack Switchgear, 1500 V, 350 A

Within a battery stack, the G5 Stack Switchgear connects to the daisy-chained Nuvation Energy G5 Cell Interface modules. The G5 Cell Interface modules convert cell voltage and temperature measurements to digital values to be relayed to the G5 Stack Switchgear, and enable or disable cell balancing as required. Daisy-chaining the G5 Cell Interface modules facilitates the design of flexible and scalable Battery Energy Storage Systems.



Figure 4. Nuvation Energy G5 Stack Switchgear

The G5 Stack Switchgear has high-voltage, high-current connectors that are accessible on the front of the unit. These connect the battery stack to the rest of the system, which is typically a common DC bus. Safety precautions are required to handle and connect cables into this unit.

The external interfaces to this unit are:

- Battery Stack and DC Bus connectors
- Service Disconnect Switch
- 10/100 Base-T Ethernet RJ45 jack (Modbus-TCP)
- Link Bus RJ45 connector
- Fan control input and output
- Power In
- Power LED and Fault LED
- Earth bonding connection (grounding stud)
- Enable, Shutdown, and Disconnect inputs
- General Purpose Inputs, and General Purpose Outputs
- Network Reset and Factory Restore

- Under Voltage Lockout (UVLO) Enable Config Switch
- AC Fan Circuit Breaker

The internal high-current path of G5 Stack Switchgear is shown in the block diagram below:

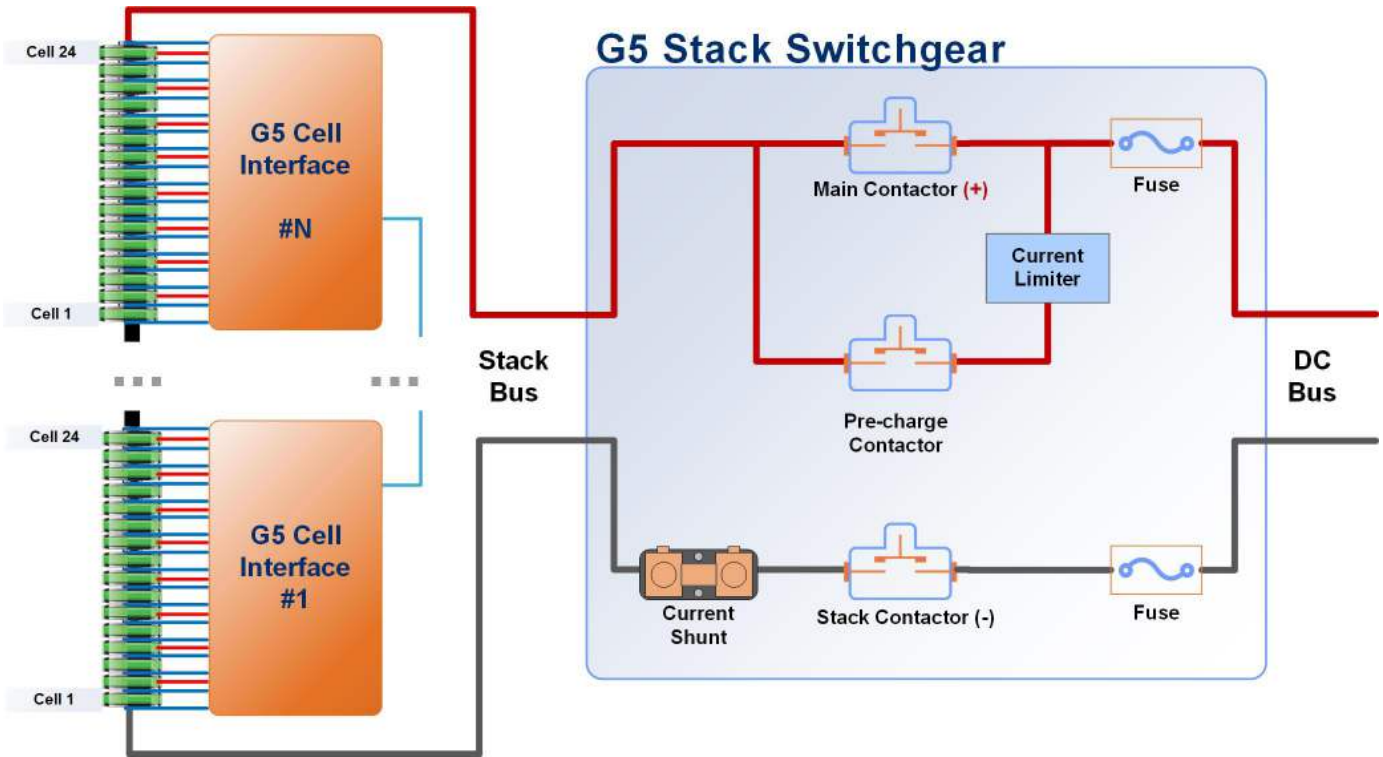

Figure 5. G5 High-Voltage BMS internal high-current path.

2.3. G5 Cell Interface

The Nuvation Energy G5 Cell Interface is the direct link between the individual battery stack cells and the rest of the Battery Management System. It facilitates battery monitoring and balancing functionalities.

In a stack managed by the G5 Stack Switchgear, one or more G5 Cell Interface modules are used to convert and relay cell voltage and temperature measurements digitally to the G5 Stack Switchgear.

The NUVG5-CI-24, G5 Cell Interface - 24 channel can monitor up to 24 series-connected cells and up to 8 external temperature sensors.



Figure 6. Nuvation Energy G5 Cell Interface

The external interfaces to this module are:

- Cell Voltage and Temperature Sensors connector
- 2 Link Bus connectors



The G5 Cell Interface connects to the battery stack-referenced signals through high voltage rated connectors. Safety precautions are required to handle and connect cables into this module.

2.4. G5 BMS Software

The Nuvation Energy G5 BMS Software is composed of two parts: the Operator Interface and the G5 BMS Firmware.

2.4.1. Operator Interface

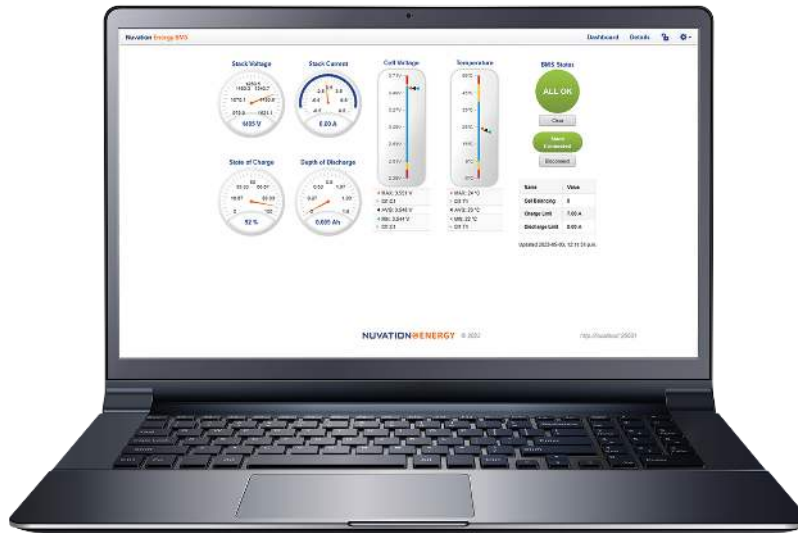

Figure 7. Operator Interface Dashboard

The Operator Interface is a browser-based graphical view of the system state, data, and configuration.

Key Features

- **Provides Unified View of Entire Battery** - Access diagnostics and performance data of the battery stack
- **Statistics** - Provides stack-level voltage, temperature & current statistics for all cells
- **Real-Time** - Streams measurements and control signals for real-time display and recording
- **Faults and Warnings** - Aggregated for system-wide overview, plus detail drill-down for battery pack diagnostics
- **SOC and SOH** - Calculates State of Charge (SoC) and State of Health (SoH) for the battery stack
- **Communications Status** - Ensures that measurements, control signals, and other data are propagating properly throughout the entire system for safe operation
- **Flow-Through I/O** - Provides a single entry point to all measurement and control points in the BMS

2.4.2. G5 BMS Firmware

The G5 BMS Firmware is a highly configurable software that manages the stack operation and

controls. It enables the BMS to be used as a protection device against unsafe voltage, temperature, and current conditions in battery systems.

Key Features

- **Configuration Registers** - Numerous configuration options, called 'registers', to tune the G5 High-Voltage BMS for the specific end-application.
- **Functional Safety** - Functional safety according to UL/CSA/IEC-60730-1 Annex H specification is accomplished through several key capabilities of the software.
 - **Protection Functions** - Provides protection functions for a battery against hazardous voltage, temperature, and current conditions.
 - **Sensor Fault Detection** - Detects sensor faults in cell voltage, temperature, stack voltage, and stack current.
 - **Shorted Shunt Detection** - Detects short circuit failures, and wiring defects.
 - **Microelectronic Fault Detection** - Implements extensive internal verification to ensure that processors, memories, and communication paths are functional and the safety software is executing correctly.
 - **Contactors Life Tracking** - Monitors the life of the contactors during the operation of the G5 Stack Switchgear. Contactor life is degraded when the contactors are opened at elevated load currents.
 - **DC Bus and Stack Connector Temperature Monitoring** - Monitors the temperature at the high power connections to the G5 Stack Switchgear. High temperatures on these connectors are an indication of untertorqued connections which can lead to a battery fire.
- **Continuous Cell Balancing** - A proprietary algorithm for continuous cell balancing leading to shorter maintenance time. The battery does not have to remain above a specific cell voltage threshold for balancing to occur.
- **Balancing Counters Per Cell** - A counter per cell for the number of times a cell was passively balanced is maintained and persisted on the G5 Stack Switchgear. This data provides a clear indication of cells which often have smaller relative capacities within the stack.
- **Configurable Modbus Points** - Provides a configurable read/write access of G5 High-Voltage BMS registers over the Modbus TCP interface.
- **Under Voltage Lockout** - A safety feature to protect a battery from further damage when either cell/stack voltages are critically low.
- **Shutdown Input** - An input signal to the G5 Stack Switchgear that when asserted will trigger a software managed disconnection of a stack followed by the G5 High-Voltage BMS powering off.
- **Disconnect Input** - An input signal to the G5 Stack Switchgear that when asserted will trigger either a software or hardware managed disconnection of a stack.
- **Fan Control** - Control AC or DC fans by either configurable cell temperature limits or manual request over a software interface.
- **Fault/Warning Bitfields** - The status of all G5 High-Voltage BMS faults and warnings are collected in separate bitfield registers. The fault/warning status can be determined by a few register reads or mapped into Modbus points via the Configurable Modbus Points feature.

3. Installation Instructions

3.1. Quick Start Guide



Prior to installation, please review the full set of safety warnings in [Important Safety Information](#).

Overview of the Installation & Setup Process

Install BMS and Batteries

1. **Install & Wire** the G5 Cell Interface modules to the batteries.
 - G5 Cell Interface: [Section 3.2.2, "Mechanical Installation"](#)
 - G5 Cell Interface: [Section 3.2.3, "Electrical Connections"](#)
2. **Install & Wire** the G5 Stack Switchgear to the G5 Cell Interface.
 - G5 Stack Switchgear: [Section 3.3.2, "Mechanical Installation"](#)
 - G5 Stack Switchgear: [Section 3.3.3, "Electrical Connections"](#)
3. **Power on** the BMS and check status LEDs.
 - Start here: [Section 3.4, "First Power-up"](#)

Install Operator Interface

1. **Install** the Operator Interface to operate the BMS.
 - Start here: [Section 3.5, "Operator Interface Installation"](#)

The G5 High-Voltage BMS is now ready for operation

3.2. G5 Cell Interface

3.2.1. Installation Overview



During all stages of the installation, appropriate Personal Protective Equipment (PPE) must be worn. This is especially critical when working with live voltages.

To complete the installation of the G5 Cell Interface, the following is required:

Cables

To connect your G5 Cell Interface you will require the following cables for each module:

- 1x Voltage and Temperature Sensors cable
- 1x Cat5e Ethernet cable

These cables are available for purchase as a kit.

The instructions below are for applications using cable harnesses purchased from Nuvation Energy. To build custom cables, refer to [G5 Cell Interface Connectors](#) for connector pin-out and specifications.

Tools and Materials

You will need the following tools and materials to complete your G5 Cell Interface installation:

- Fasteners and tools for attaching the G5 Cell Interface to the end desired surface.
- G5 Cell Connection Tester - To detect wiring errors that could damage a G5 Cell Interface. Contact support@nuvationenergy.com to purchase.

3.2.2. Mechanical Installation

3.2.2.1. Dimensions and Weight

The overall dimensions of the G5 Cell Interface are 118.5mm x 116.2mm x 25.4mm and weighs approximately 116g. The G5 Cell Interface is available in a bulkhead-mountable enclosure as shown below.

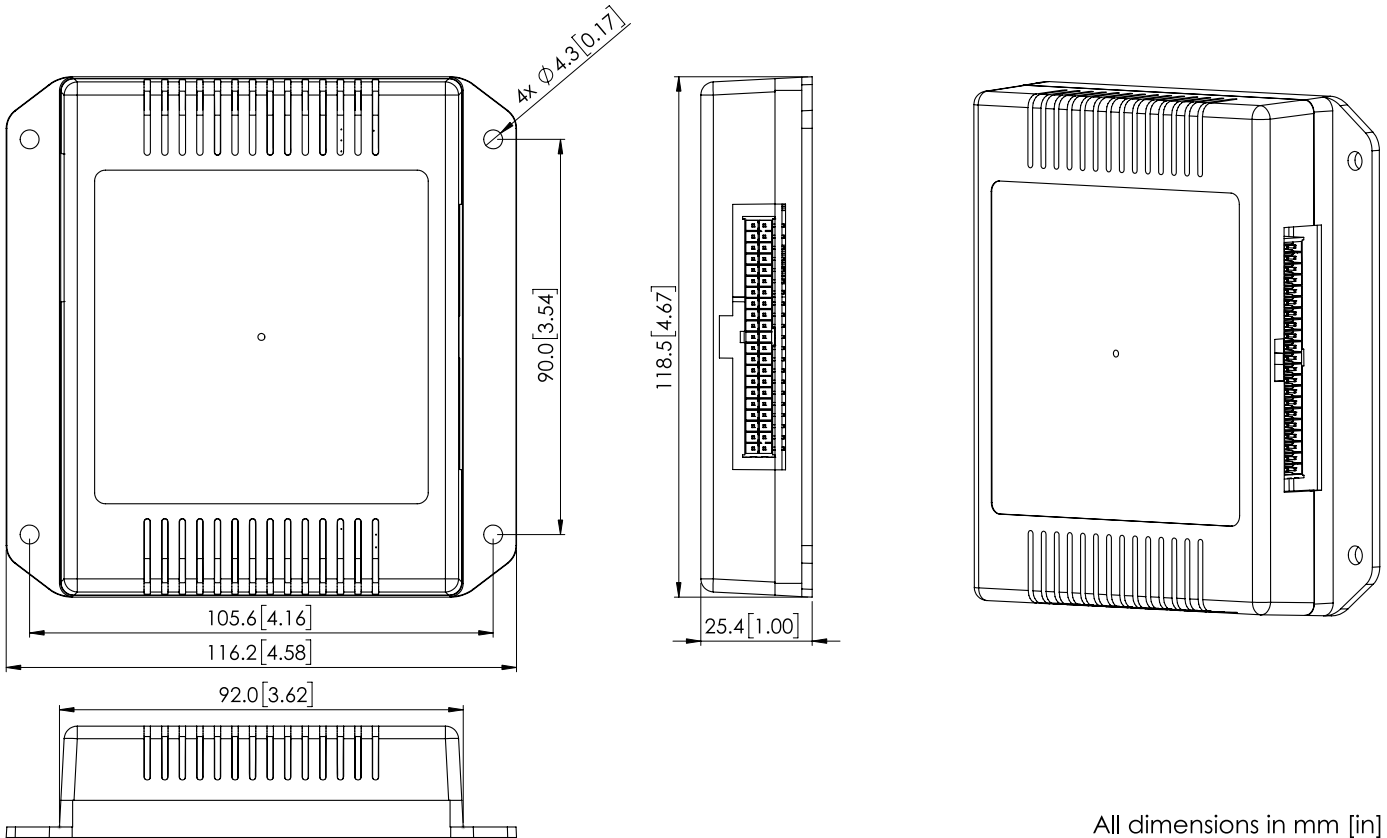

Figure 8. Mechanical Drawing of G5 Cell Interface



Please refer to <https://www.nuvationenergy.com/technical-resources> for access to CAD files.

3.2.2.2. Installation Location and Position

Mounting Clearances

The G5 Cell Interface produces up to 15 W during cell balancing. A portion of this heat is transferred to the bulkhead.

Extra space should be provided around the G5 Cell Interface module to allow for sufficient heat dissipation, and cable installation.

3.2.2.3. Mounting Instructions

The G5 Cell Interface is rated to operate in the temperature range of -20 °C to 60 °C. It is designed for indoor use.

The G5 Cell Interface should be mounted against a flat surface with vent above the Nuvation Energy logo pointing up to the sky.



If the mounting surface is conductive, ensure it has been connected securely to Earth.

Ensure appropriate fasteners (not included) are used to mount the G5 Cell Interface. These fasteners will vary depending on the material and construction of the mounting surface.

It is suggested to use M4 screws with a split lock washer for the mounting holes provided on each side flange of the G5 Cell Interface.

3.2.3. Electrical Connections



The G5 Cell Interface connects to the battery stack-referenced signals through high-voltage rated connectors. Safety precautions are required to handle and connect cables into this module.

3.2.3.1. Getting Started

To complete the installation of the G5 Cell Interface, the following is required:

1. 1x Voltage and Temperature Sensors Cable
2. 1x Cat5e Ethernet Cable

These cables are available for purchase as a kit from <https://nstore.nuvationenergy.com>.



Figure 9. Example G5 Cell Interface kit contents

Connection sequence

- Step 1: [Connect the Voltage and Temperature Sensors Cable](#)
- Step 2: [Connect the Link Bus Cable](#)



The wiring of the battery cell voltage and temperature sensing should be verified **before** connecting to the G5 Cell Interface modules. The temperature sensing must be isolated from the cell voltage sensing and Earth. Wiring errors can cause damage to the G5 Cell Interface and/or the cells.

3.2.3.2. Connect the Voltage and Temperature Sensors Cable

Table 1. Voltage and Temperature Sensors - Port and Cable options



Figure 10. Cell Voltage and Temperature Sensors port



Figure 11. Voltage and 2 Temperature Sensors Cable (NUVW-C23A15-020)



Figure 12. Voltage and 8 Temperature Sensors Cable (NUVW-C24A15-020)



Your G5 Stack Switchgear is pre-configured to expect a defined number of cells and thermistors based on the information provided to Nuvation Energy during order fulfillment. Failure to use the same number of cells and thermistors will result in undesirable G5 Stack Switchgear behavior.

Please contact support@nuvationenergy.com if there is a change requiring a G5 Stack Switchgear configuration update.

The Voltage and Temperature Sensors cables include cell temperature and cell voltage sensor wires.

Temperature Sensor wires with Thermistors

The temperature sensor wires include 10 kΩ NTC thermistors for temperature measurement of the cells and surrounding area. These sensors are used by Nuvation Energy BMS to detect over and under temperature conditions and adjust battery current limits to compensate for cell temperature.

Cable Isolation

Because the temperature sensors are referenced to the CI_REF1- input on the G5 Cell Interface, care must be taken to ensure that they are electrically isolated from any common or ground potential, and from all other cell voltage terminals of all G5 Cell Interface modules in the system.

The thermistors must also be isolated from the cell voltage terminals, as well as any metal work or other exposed conductors, in such a way that they will not make an electrical connection to a cell terminal in the event of vibration or failures.

Voltage Sense wires

The voltage sense wires provide a means of sensing cell voltage. These wires also carry current used to balance the cells. The Voltage and Temperature Sensors cables provided by Nuvation Energy have the voltage sense wires labelled for ease of installation. Be aware that the wires are unterminated and unused cell voltage sense wires must be connected to adjacent cells. Do not leave these wires unterminated in the end-application, as their cut ends are not insulated.

Power Requirements

The G5 Cell Interface module is powered by the battery cells. The cells are connected as two groups, and a minimum of 11.2 V DC must be present between the most negative and most positive cells of each group. See specifications in [Section 5.1.2.1, "Electrical Characteristics"](#).

Connection Procedure



The G5 Stack Switchgear is configured for a specific battery topology based on the details provided to Nuvation Energy during order fulfillment. Failure to use the same number of G5 Cell Interface modules or using a different battery topology will result in undesirable G5 Stack Switchgear behavior.

Please contact support@nuvationenergy.com if there is a change in the system design that would require a G5 Stack Switchgear configuration update.



If you are building your own cables, please refer to the pin-out for this connector in [Cell Voltage and Temperature Connector](#).

Connect Temperature Sensors to Cell Surface

It is recommended to use thermally conductive and electrically non-conductive epoxy to adhere the thermistors to the cells.

Connect Voltage Sense Wires to Battery Cells

Connect the G5 Cell Interface voltage sense wires to the battery voltage terminals. The individual wires are labelled to help with identifying the connections. Refer to the [Wiring Examples](#) to wire a differing number of cells to a G5 Cell Interface.

- Begin at the negative post of the battery at the bottom of the stack.
- Connect the CI_REF1- pin on the voltage sense harness to the negative post of the battery at the bottom of the stack.
- For the first G5 Cell Interface in the Link Bus Chain, this negative post will also be connected to

the G5 Stack Switchgear Battery (-) terminal, as shown in the G5 Stack Switchgear [Battery Stack and DC Bus Connector Lugs](#).

- The CI_REF1- pin, with the Cell 1+ pin on the positive terminal of this battery, serves as Cell 1.
- Additional cell voltage sense wires are connected to the next battery cells in ascending series voltage, with the last cell voltage sense wire ending on the Cell 24+ pin.
- For scenarios with more than 24 cells, additional G5 Cell Interface modules are required. The connection pattern repeats in blocks of 24 (cells 25 to 48, 49 to 72 etc.), until the desired stack voltage is reached, up to a maximum of 1500 V DC.

Verify Connections

- The wiring of the battery cell voltage and temperature sensors should be verified before connecting to the G5 Cell Interface modules.
- The temperature sensors must be isolated from the cell voltage terminals.
- Wiring errors can cause damage to the G5 Cell Interface and the battery cells.



Nuvation Energy recommends using the G5 Cell Connection Tester to verify connections and detect wiring errors that could damage a G5 Cell Interface. Please contact support@nuvationenergy.com to purchase.

Connect Cable to G5 Cell Interface

- Connect the Voltage and Temperature Sensors cable to the connector on the right side of the G5 Cell Interface.

Wiring Examples

The diagrams below show the common wiring scenarios for connecting battery cells to a G5 Cell Interface. If your G5 Stack Switchgear is pre-configured to expect less than 24 cell inputs to the G5 Cell Interface, please connect the unused cell inputs to the battery stack as shown in the last two diagrams.

- [Wiring 24 cells](#)
- [Wiring 20 cells](#)
- [Wiring 13 cells](#)

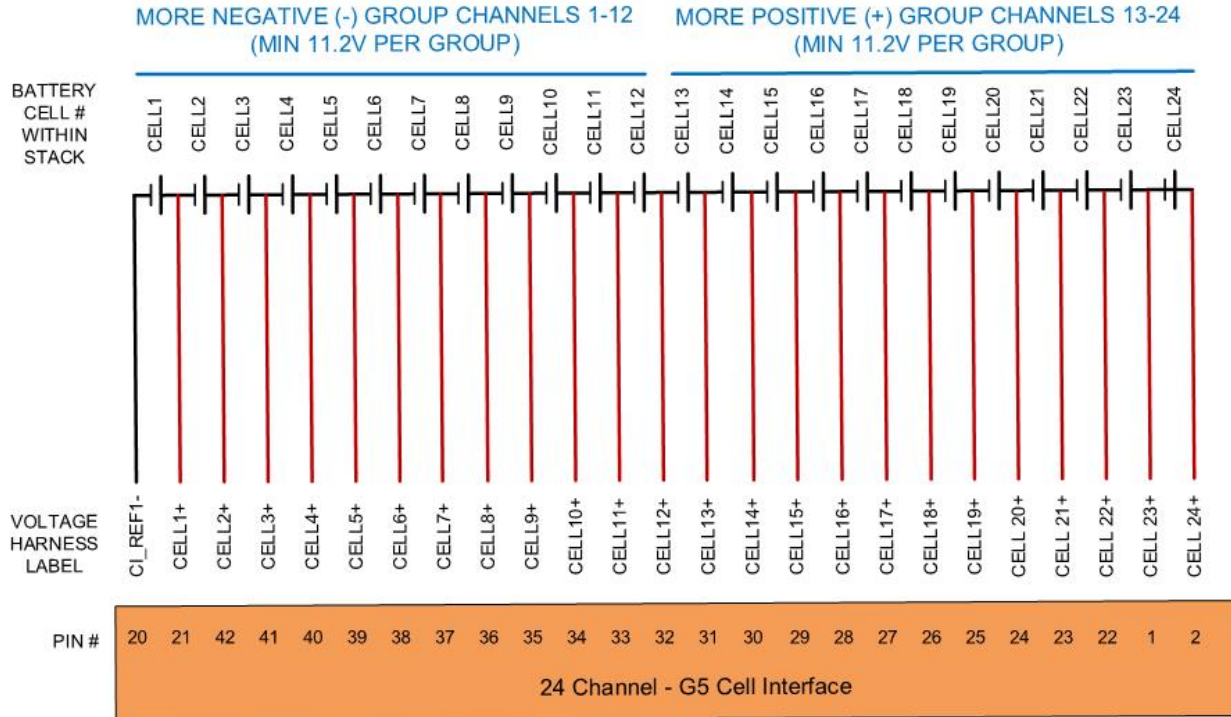

Figure 13. Example wiring 24 cells in a G5 Cell Interface - 24 channel

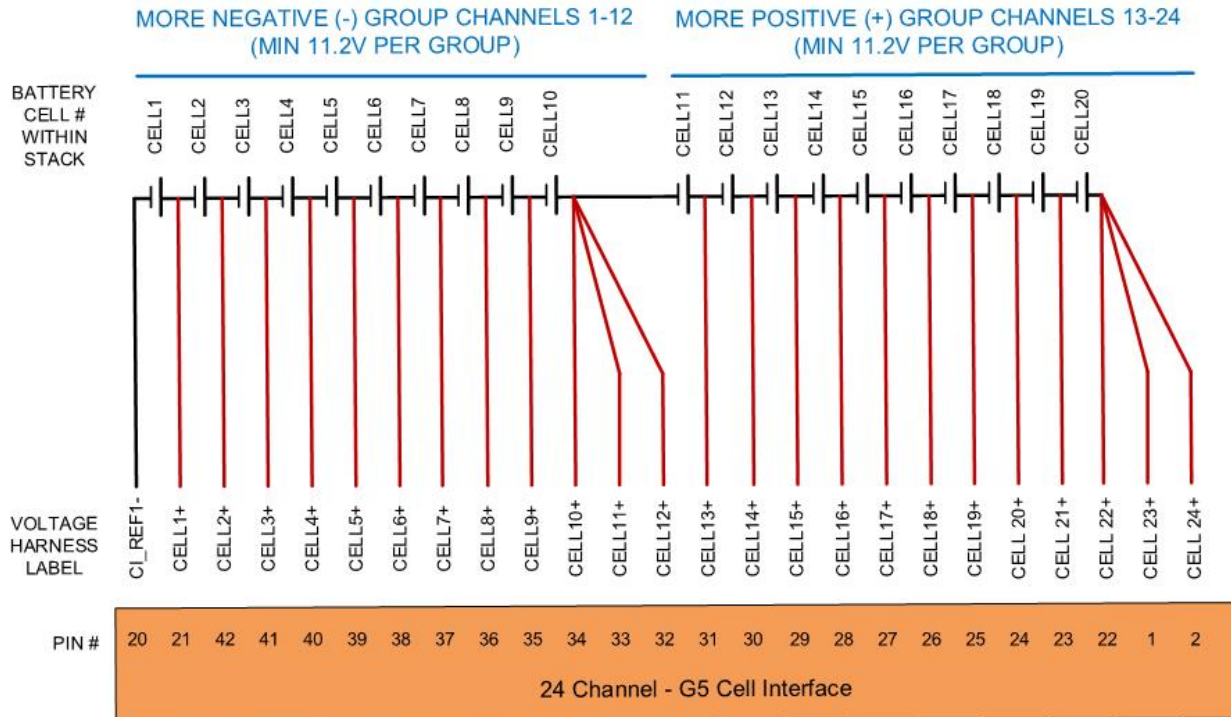

Figure 14. Example wiring 20 cells in a G5 Cell Interface - 24 channel

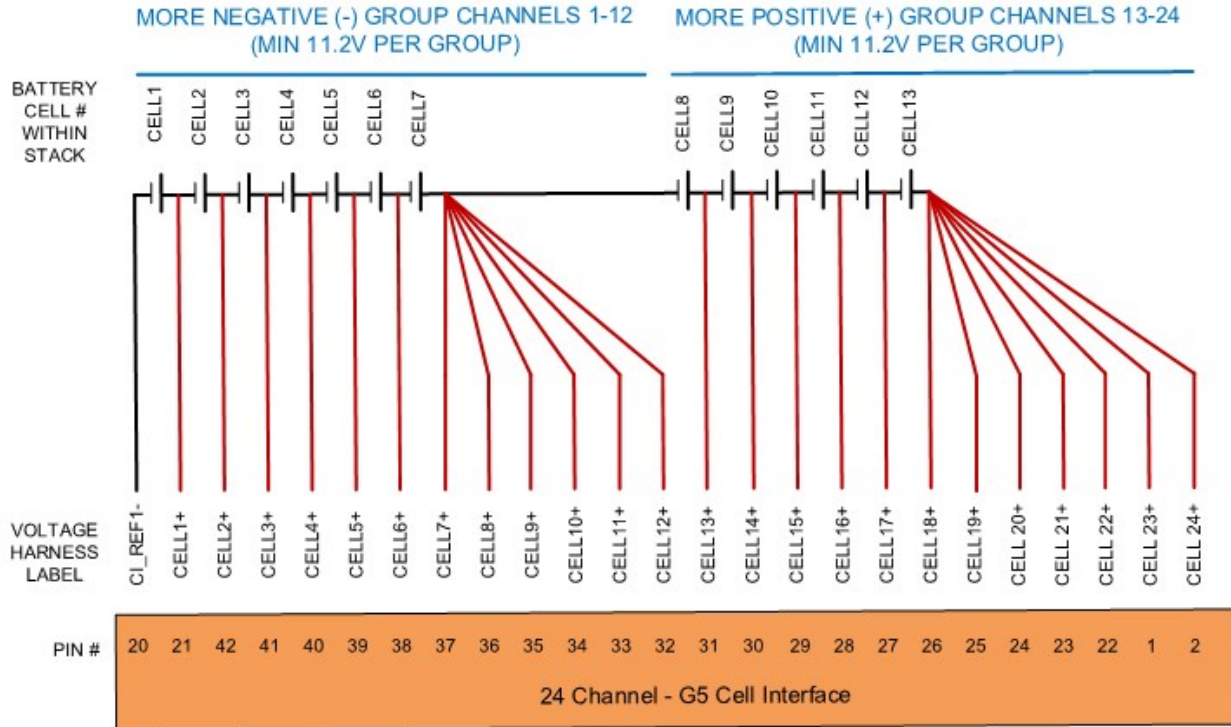

Figure 15. Example wiring 13 cells in a G5 Cell Interface - 24 channel

3.2.3.3. Connect the Link Bus Cable

Table 2. Link In and Link Out - Ports and Cable



Figure 16. Link In and Out Connector



Figure 17. Ethernet cable (NUVW-D01X00-020)

The Link Bus cable is a standard Cat5e RJ45 Ethernet cable.

- Link Bus Chain communications start with the G5 Stack Switchgear, continue to the G5 Cell Interface at the bottom of the stack, and end at the G5 Cell Interface at the top of the stack, using

standard Ethernet cables.

- The Link Bus cable is used to connect G5 Cell Interface modules in a daisy chain (called the Link Bus chain) by connecting the 'Link Out' of one G5 Cell Interface to the 'Link In' of the next G5 Cell Interface in ascending series voltage order.
- The Link Bus provides a data channel to subsequent G5 Cell Interface modules in the Link Bus chain.

Cable Isolation

The Link Bus cable contains signals that are isolated from the battery cells and its voltage level is within SELV limits. The cable can touch the grounded metal of the battery rack. However, it must not touch the battery cells. Failure to properly insulate the Link Bus from contact with the battery terminals can damage the G5 Battery Management System and cause harm to the user.

Connection Procedure

1. Begin with the First G5 Cell Interface in the Link Bus Chain, connected to the most negative battery cells at the bottom of the stack.
2. Connect one end of the link bus cable to the 'Link Out' connector on the first G5 Cell Interface.
3. Connect the other end of the Link Bus cable to the 'Link In' connector on the next G5 Cell Interface.
4. The connection pattern repeats for each succeeding G5 Cell Interface in the stack.
5. The last G5 Cell Interface connected is electrically located at the top of the stack.
6. This last G5 Cell Interface is connected to the battery cell whose positive terminal will be connected to the Battery (+) post of the G5 Stack Switchgear as shown in [Battery Stack and DC Bus Connector Lugs](#).

The 'Link Out' of the last G5 Cell Interface module in the Link Bus chain is left unconnected.

To complete the Link Bus chain communications in [Section 3.3.3.8, "Connect Link Out cable to G5 Cell Interface"](#), a Link Bus cable will connect:

- the 'Link Out' connector of the G5 Stack Switchgear to
- the 'Link In' connector of the first G5 Cell Interface in the Link Bus Chain, at the bottom of the stack.

3.3. G5 Stack Switchgear

3.3.1. Installation Overview



During all stages of the installation, appropriate Personal Protective Equipment (PPE) must be worn. This is especially critical when working with live voltages.

To complete the installation of the G5 Stack Switchgear, the following is required:

Mounting Brackets

Brackets for shelf mounting are included. Optionally, you can request Front-securing Brackets for 19" Rack mounting if appropriate for your application. A third option is for users to source brackets which uphold the weight of the unit.

Cables

To connect your G5 Stack Switchgear you will require the following cables:

- 1x Power and Fan Cable for either AC or DC power.
- 1x Cat5e Ethernet cable for communication with a computer
- 1x GPIO Control Cable

These cables are available for purchase as a kit.

The instructions below are for applications using cable harnesses purchased from Nuvation Energy. To build custom cables, refer to [G5 Stack Switchgear Connectors](#) for connector pin-out and specifications.

Tools and Materials

You will need the following tools and materials to complete your G5 Stack Switchgear installation:

- M13 and M17 wrench
- Torque wrench with range 60-130 inch pounds
- Fasteners and tools for attaching the brackets to the end desired surface.

3.3.2. Mechanical Installation

3.3.2.1. Dimensions and Weight

The G5 Stack Switchgear is 4U (rack-units) tall. The unit weighs 23.5 kg [51.8 lbs].

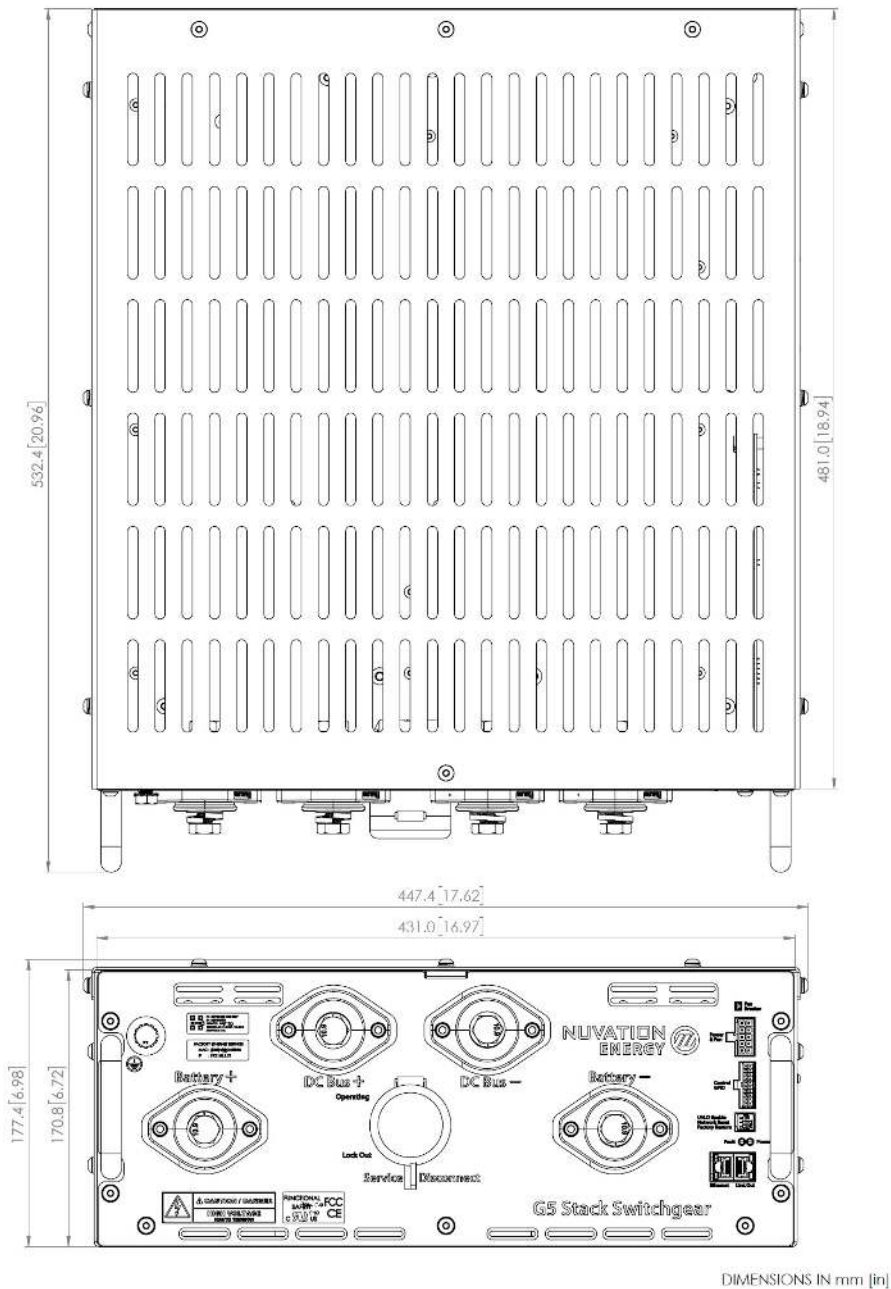

Figure 18. Mechanical Drawing of G5 Stack Switchgear



Please refer to <https://www.nuvationenergy.com/technical-resources> for access to CAD files.

3.3.2.2. Installation Location and Position

The G5 Stack Switchgear is primarily designed to fit in a standard 19" rack with a 23"-deep cabinet. However, other mounting possibilities are supported, as the following subsections discuss. By default, the G5 Stack Switchgear ships with brackets for shelf mounting. Depending on the desired application, brackets can be ordered with part numbers listed in [G5 Stack Switchgear Ordering Information](#).

The G5 Stack Switchgear must be installed in a horizontal orientation with the vent-slots pointing up to the sky. The G5 Stack Switchgear is not designed to be installed in any other orientation.

Mounting Clearances

To maintain safe operating temperatures, it is recommended to leave 1U of space above the unit for airflow. Depending on the environment, active airflow, and ambient temperature, some installations may require additional space.

3.3.2.3. Mounting Instructions

Fasteners (M5 x 8 mm) for attaching the brackets to the G5 Stack Switchgear unit are included with any mounting bracket order.



If fasteners other than the provided hardware is used, the screws cannot extend into the G5 Stack Switchgear more than 5.5 mm. High-voltage and high-power elements that exist inside the unit could arc to the screw if it intrudes too deep into the unit.

Fasteners for attaching the brackets to the end desired surface are not provided, due to the application-specific nature. In order to source these fasteners, note that the corresponding bracket slots have widths designed for M5 screws.

After removing the G5 Stack Switchgear from its packaging, perform the following steps based on the mounting brackets purchased.

Shelf-Mount

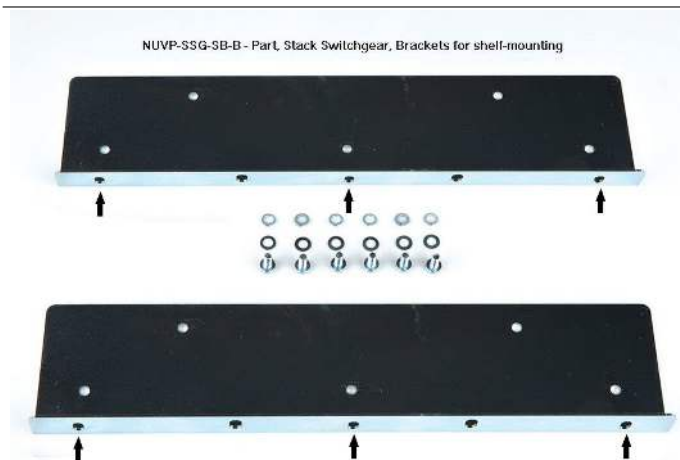

Figure 19. Shelf Mount (NUVP-SSG-SB-B)



Figure 20. Product with brackets installed

A G5 Stack Switchgear may be mounted on a horizontal surface, with the aid of shelf-mount brackets, as shown above.

1. Install the brackets on the G5 Stack Switchgear. Install at least 3 screws in each shelf bracket as indicated with arrows above. The recommended tightening torque is 4.5 to 5 N-m [40 to 44 in-lbs].
2. Place the G5 Stack Switchgear on a shelf or level surface at the desired location. Ensure the G5 Stack Switchgear is in a horizontal orientation with the vent-slots pointing up to the sky.
3. Attach the G5 Stack Switchgear (with brackets installed) to the shelf or level surface.

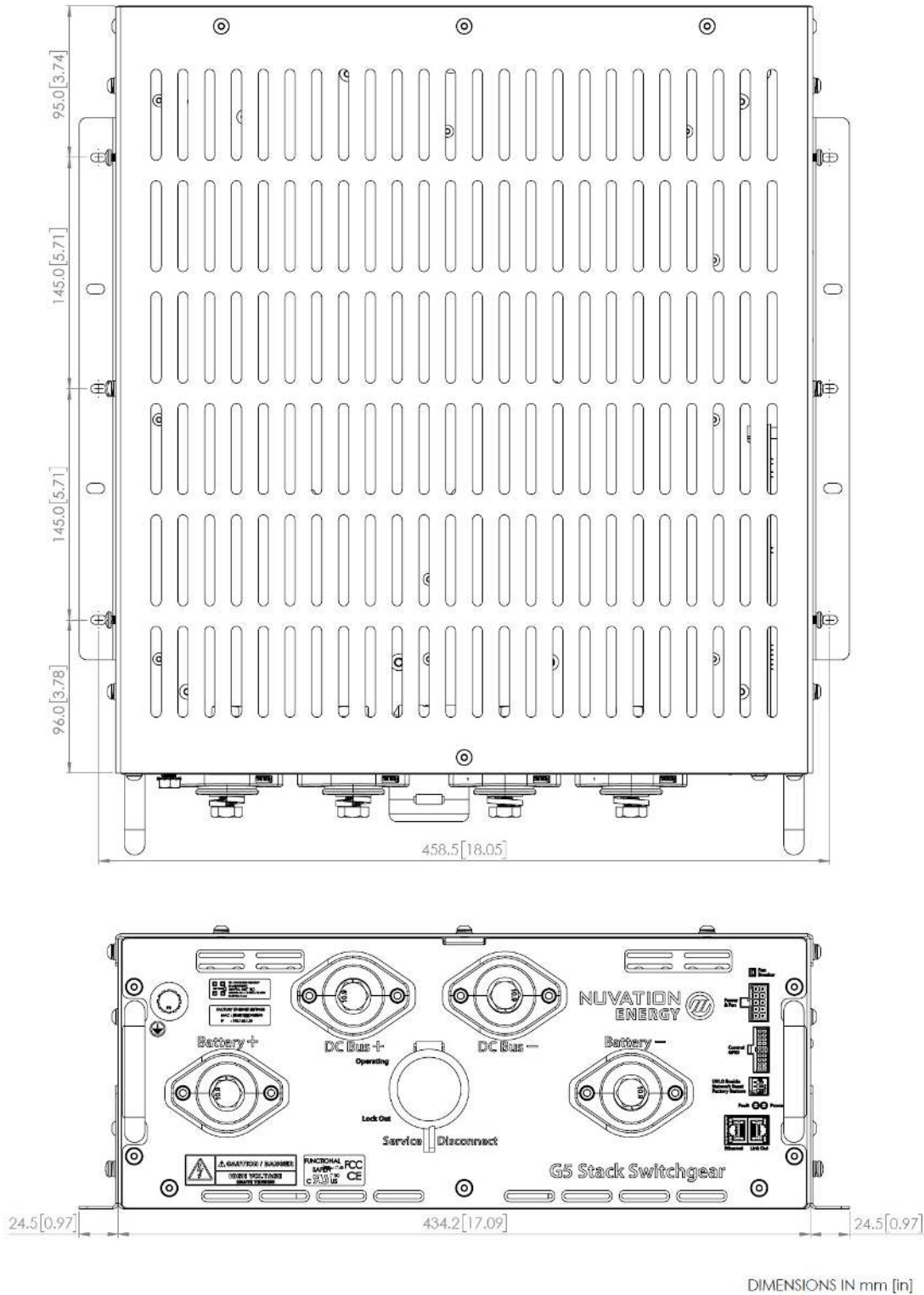

Figure 21. Dimensions, shelf-mount

Front-securing Rack-Mount, 19"



Figure 22. Rack Mount (NUVP-SSG-RB-19-B)



Figure 23. Product with brackets installed

These brackets are designed to secure the front of the unit with respect to the front of the rack. The mounting brackets allow for adjusting how far the unit protrudes or recedes from the front of the rack.



Side-support angle brackets are necessary to uphold the weight of the unit, in this mounting application.

Some third-party examples include RASA22BK3 or RAAB2436BK products by Hammond Manufacturing (<https://www.hammfg.com/>).

1. Install the side-support angle brackets on the rack at the desired location.
2. Install the front-securing brackets on the G5 Stack Switchgear. Install 2 screws in each bracket. The recommended tightening torque is 4.5 to 5 N-m [40 to 44 in-lbs].
3. Place the G5 Stack Switchgear onto the installed side-support angle brackets. Ensure the G5 Stack Switchgear is in a horizontal orientation with the vent-slots pointing up to the sky.
4. Secure the G5 Stack Switchgear to the rail of the rack using the front-securing brackets installed.

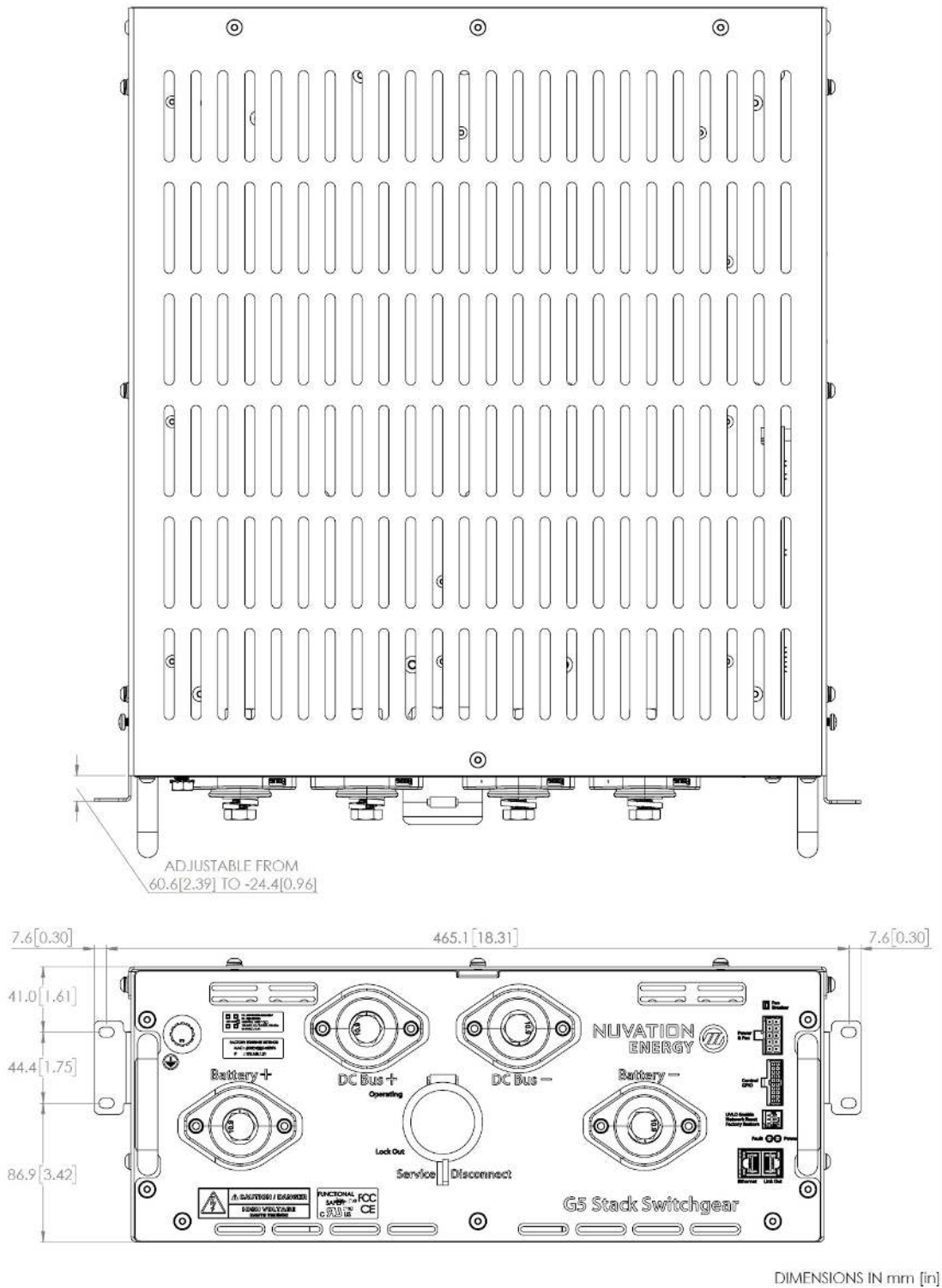

Figure 24. Dimensions, rack-mount, 19", front-securing

3.3.3. Electrical Connections



Before making any connections, ensure that the service disconnect switch is in the **Lock Out** position.



The G5 Stack Switchgear is configured for a specific battery topology based on the details provided to Nuvation Energy during order fulfillment. Failure to use the same number of G5 Cell Interface modules and/or using a different battery topology will result in undesirable G5 Stack Switchgear behavior.

Please contact support@nuvationenergy.com if there is a change in the system design that would require a G5 Stack Switchgear configuration update.

3.3.3.1. Getting Started

To complete the installation of the G5 Stack Switchgear, the following is required:

1. 1x Power and Fan Cable
2. 1x Cat5e Ethernet Cable
3. 1x GPIO Control Cable

These cables are available for purchase as a kit from <https://nstore.nuvationenergy.com>.

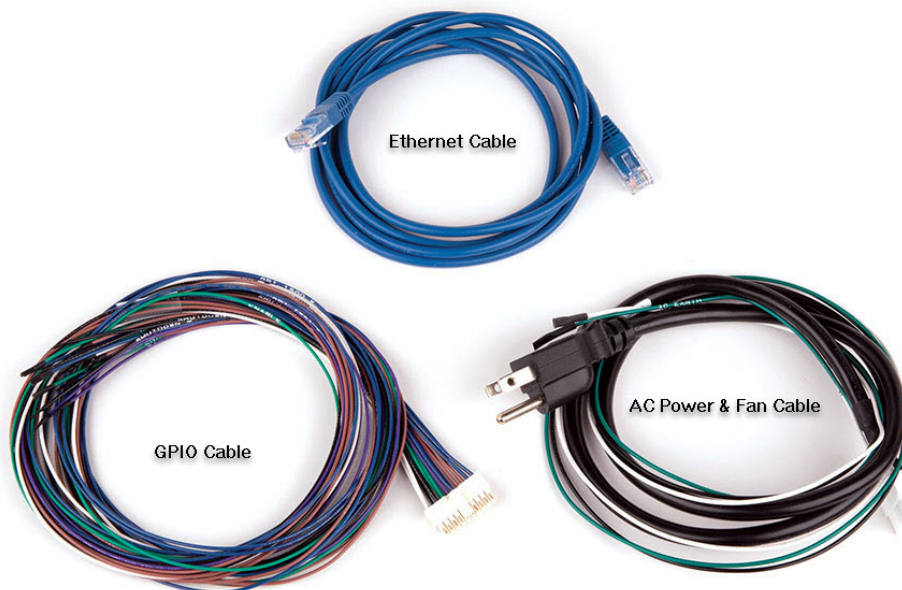

Figure 25. Example G5 Stack Switchgear cable kit contents

The instructions below are for applications using cable harnesses purchased from Nuvation Energy. To

build custom cables, refer to [G5 Stack Switchgear Connectors](#) for connector pin-out and specifications.

Connection sequence

- Step 1: [Ensure system is de-energized](#)
- Step 2: [Ground the G5 Stack Switchgear](#)
- Step 3: [Connect Power In and Fan Control](#)
- Step 4: [Connect control to General Purpose Input/Output \(GPIO\) cable](#)
- Step 5: [Connect Ethernet cable to external computer \(PC\)](#)
- Step 6: [Connect Link Out cable to G5 Cell Interface](#)
- Step 7: [Set the Config Switches](#)
- Step 8: [Connect Battery Stack to DC Bus](#)

Below is an overview image of the connectors available on the front of the G5 Stack Switchgear.



Figure 26. G5 Stack Switchgear

3.3.3.2. Ensure system is de-energized



Ensure that the Service Disconnect switch is in the **Lock Out** position.

Service Disconnect

The manual Service Disconnect switch is accessible on the front of the G5 Stack Switchgear. Use the lock-out/tag-out function to ensure that the battery stack does not connect to the DC bus or Power Conversion System (PCS) during installation.

Ensure the service disconnect switch is in the **Lock Out** position and lock-out/tag-out the switch by locking the cover.



Figure 27. Service Disconnect

The service disconnect switch removes power to the internal contactors—it does not physically break the connection (this is done by the contactors themselves).



In the very unlikely event of damage to both internal contactors (i.e. two welded contactors), the service disconnect switch cannot guarantee that the DC bus has been disconnected from the battery. It is therefore recommended to check for voltage present on the Battery Stack and DC Bus terminals with a voltmeter before working on the stack to ensure the contactors have opened fully.

Verify G5 Stack Switchgear is de-energized

Using a multimeter check the Battery Stack and the DC Bus terminals respectively to verify that the G5 Stack Switchgear is de-energized.

3.3.3.3. Ground the G5 Stack Switchgear



Figure 28. Grounding bolt

The G5 Stack Switchgear must be bonded to the rack or Earth through a suitably sized conductor by NEC standards. From NFPA 70, Table 250.122, the wire size must be chosen based on the rating of

the automatic over-current device in the circuit, as shown in [Table 3, "Minimum grounding wire size"](#).

Table 3. Minimum grounding wire size

G5 Stack Switchgear Current Rating (A)	Grounding Wire (AWG)	
	Copper	Aluminum
200	6	4
300	4	2
350	3	1

An M8 lug (not included) should be used (e.g. Panduit Corp LCMA50-8-L), along with an M8 bolt and tooth lock washer (both included), as shown in [Figure 28, "Grounding bolt"](#).

In order to make the connection:

1. Strip the insulation
2. Crimp the lug
3. Screw the lug onto the terminal

The recommended tightening torque is 15 N-m [130 in-lbs].

3.3.3.4. Connect Power In and Fan Control

On the front panel, the G5 Stack Switchgear internal power and external fan power is connected via the Power and Fan cable connector.

Table 4. Power and Fan - Port and Cable options



Figure 29. Power and Fan port

Compatible with either AC or DC cable.



Figure 30. AC cable (NUVW-B15H03-010)



Figure 31. DC cable (NUVW-B16H03-010)



If you are building your own cables, please refer to the pin-out for this connector in [Power and Fan Connector](#). For specifications of this input, see [Section 5.1.1, "G5 Stack Switchgear"](#).

The G5 Stack Switchgear requires a 100 V to 240 V AC or a 24 V DC power to be supplied from an external source which must be de-energized before installation.

Fan control enables the G5 Stack Switchgear to control external AC or DC fans for cooling the battery cells.

- If DC Fans are used, an external DC power source is required
- If AC Fans are used, an external AC power source is required
- If a DC and an AC power source are both provided, the AC source is used to power the G5 Stack Switchgear

The fans are enabled by the BMS when battery cell temperatures exceed configurable thresholds.

The figure below provides the internal wiring implementation of the fan control parts shown above.

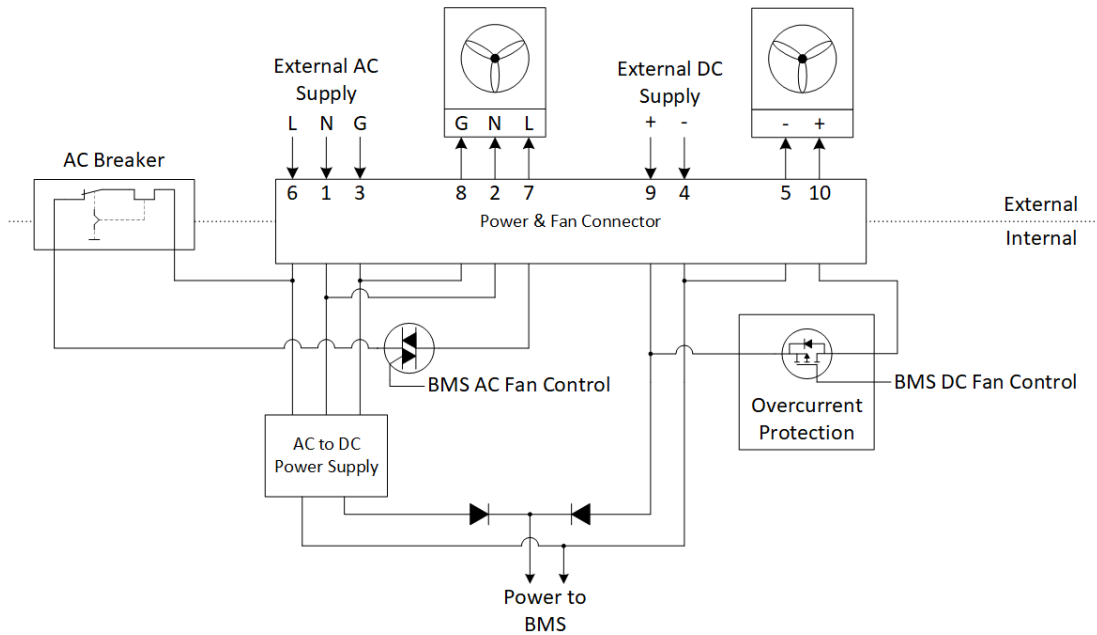

Figure 32. Battery cooling fan control wiring diagram



Power to the G5 Stack Switchgear and the fans is expected to be de-energized before installation; this involves turning off power at the end application.

Plug in the Power & Fan cable to the connector on the front of the G5 Stack Switchgear.

3.3.3.5. AC Fan Breaker and DC Fan Overload Protection

The Fan Breaker shown above in [Figure 32, "Battery cooling fan control wiring diagram"](#) is only for AC powered fans. The AC fan breaker does not provide digital feedback and requires a manual reset in the event of an overload. After resolving the cause of the overload, the AC Fan breaker can be reset by carefully pressing in the breaker, no more than 2 mm, until a click is felt.

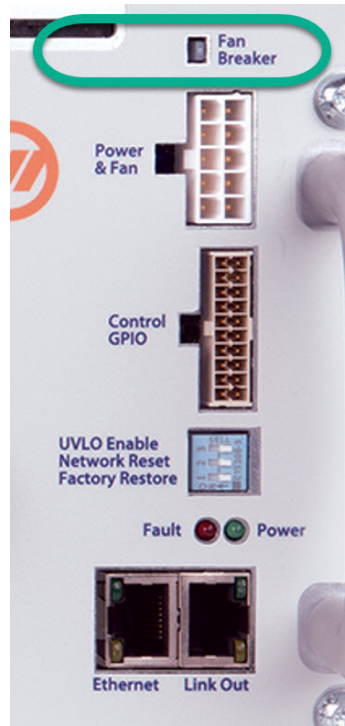

Figure 33. AC Fan Breaker

DC Fan Overload Protection is provided by an internal smart integrated circuit which sends feedback to the system if it trips due to an overload. The integrated circuit can auto-reset when the cause of the overload trip has been resolved.

3.3.3.6. Connect control to General Purpose Input/Output (GPIO) cable

This Control GPIO cable harness includes special input signals, 2 General Purpose Outputs (GPO) and 2 General Purpose Inputs (GPI). Use the cable harness to connect external equipment to the GPIO interface.

This interface provides connections to special function input signals that can:

- Enable the G5 Stack Switchgear power supply (see [Section 4.11.5, "Under-Voltage Lockout"](#))
- Invoke or force a G5 Stack Switchgear system shutdown (see [Shutdown Input](#))
- Invoke or force the G5 Stack Switchgear to disconnect the battery stack (see [Disconnect Input](#))

General purpose outputs and inputs are configured by the end-user to match their needs.

This interface provides connections to isolated general purpose outputs and inputs, that can be used for signals such as:

- G5 Stack Switchgear fault state output - signal external devices when internal faults are present
- G5 Stack Switchgear trigger state output - signal an external LED when a specific trigger is tripped
- PCS emergency OFF input

- Ground Fault Detector input
- Manual clear G5 Stack Switchgear faults input

Connect the Control GPIO cable to the connector on the front of the G5 Stack Switchgear.

Table 5. Control GPIO - Port and Cable options



Figure 34. Control GPIO port



Figure 35. GPIO cable (NUVW-C26H03-010)



If you are building your own cables, please refer to the pin-out for this connector in [I/O Connector](#).

3.3.3.7. Connect Ethernet cable to external computer

Connect the Ethernet cable between the Ethernet port on the G5 Stack Switchgear and an external computer.

Table 6. Ethernet - Port and Cable options



Figure 36. Ethernet Connector



Figure 37. Ethernet cable (NUVW-D01X00-020)

The Ethernet connector is a standard RJ45 Ethernet jack. It may be used to connect the G5 Stack Switchgear to an external system, such as:

- A laptop, to configure operating parameters and observe status
- A local area network (LAN) connection
- A Nuvation Energy Multi-Stack Controller
- Energy control systems, such as PCSs and energy controllers
- An Ethernet switch, to access any number of the above devices

Any Cat5e-rated or higher Ethernet cable of suitable length may be used to connect to this RJ45 jack.

3.3.3.8. Connect Link Out cable to G5 Cell Interface

If the G5 Cell Interface modules are not already connected to the battery (e.g. battery cell voltage sensors, temperature sensors, and Link Bus cables between the G5 Cell Interface modules), this can be done now. For instructions on connecting the G5 Cell Interface modules to the battery, refer to [Section 3.2.3, "Electrical Connections"](#).

The G5 Cell Interface cable kit includes a standard Cat5e Ethernet cable. Connect this Ethernet cable between the G5 Stack Switchgear and the First G5 Cell Interface in the Link Bus Chain. The Link Bus chain communication is complete when the Ethernet cable connects the 'Link Out' connector of the G5 Stack Switchgear to the 'Link In' connector of the first G5 Cell Interface.

Table 7. Link Out - Port and Cable options



Figure 38. Link Out Connector



Figure 39. Ethernet cable (NUVW-D01X00-020)

The Link Out connector provides communication to the G5 Cell Interface modules.

Typically, the Link Bus is connected to the G5 Cell Interface module which measures the most negative cell, with each subsequent G5 Cell Interface module measuring increasingly positive cells. This ensures that the software registers and the Operator Interface will sequence the cells in an intuitive order of increasing potential.

3.3.3.9. Set the Config Switches

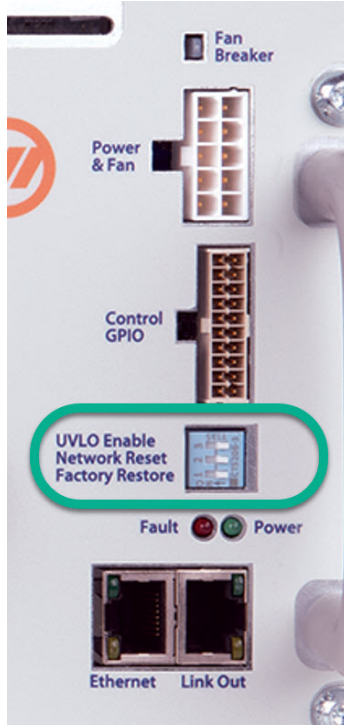

Figure 40. Config Switches

Set the switch positions for the desired functionality that they manage.



The G5 Battery Management System will continue to discharge battery cells below the low voltage fault threshold unless UVLO has been enabled. For unattended applications, it is strongly encouraged to enable UVLO.

- Network Reset and Factory Restore are not required during installation of a new G5 Stack Switchgear.
- A config switch set to the left is **ON**, and set to the right is **OFF**.

The following table describes the functionality per config switch.

Table 8. Config Switch Settings

Switch	Name	Position	Description
3	UVLO Enable	Off	UVLO is disabled
3	UVLO Enable	On	UVLO is enabled
2	Network Reset	Off	No action
2	Network Reset	On	Enables a user to select a Network Reset during the subsequent power on. See instructions below.
1	Factory Restore	Off	No action
1	Factory Restore	On	Enables a user to select an Factory Restore during the subsequent power on. See instructions below.

Network Reset

With the Network Reset switch in the ON position, supply power to the G5 Stack Switchgear to turn it on.

If the position of the Network Reset switch is returned to the OFF position while the LEDs are blinking, the Ethernet network settings will be restored to the Factory Network Settings stated on the front of the G5 Stack Switchgear. If the Network Reset switch remains in the ON position for 30 seconds from the time power is supplied, the G5 Stack Switchgear continues execution ignoring the Network Reset switch.

Factory Restore

With the Factory Restore switch in the ON position, supply power to the G5 Stack Switchgear to turn it on.

If the position of the Factory Restore switch is returned to the OFF position while the LEDs are blinking, the G5 Stack Switchgear will be restored to the same version of firmware and configuration settings (including Network settings) that it had when it released from the factory.

If the Factory Restore switch remains in the ON position for 30 seconds from the time power is supplied, the G5 Stack Switchgear continues execution ignoring the Factory Restore switch. The network configuration is reset when a factory restore is performed.



Changes in config switch settings must occur when the Nuvation Energy G5 Stack Switchgear is powered off.

Prior to attempting a Factory Restore, contact support@nuvationenergy.com, to obtain more details on recalibrating and restoring the Nuvation Energy G5 Stack Switchgear to its factory state.

3.3.3.10. Connect Battery Stack and DC Bus



Due to the nature of batteries, live voltages are always present; for this reason, these connections should be completed last. In order to reduce the risk of a short, only install one connection at a time.



The G5 Stack Switchgear is configured for a specific battery topology based on the details provided to Nuvation Energy during order fulfillment. Failure to use the same number of G5 Cell Interface modules and/or using a different battery topology will result in undesirable G5 Stack Switchgear behavior.

Please contact support@nuvationenergy.com if there is a change in the system design that would require a G5 Stack Switchgear configuration update.

The front panel of the G5 Stack Switchgear has four high-power connectors, as illustrated below. Two of these are for the positive and negative terminals of the battery stack; the other two are for the connection to the DC bus (or a PCS in a single stack system). The colors are coordinated such that red is for the positive connections and black is for the negative connections.

The connectors use M10 screws (included) and are intended for M10 lugs (not included, e.g. Panduit Corp LCMA50-10-L).

Flexible snap-on terminal covers are included. The maximum acceptable terminal lug tongue width is 1.1 inches and the maximum wire outer diameter (including insulation) is 0.817 inches. The recommended tightening torque is 6.8 N-m to 9.0 N-m [60 to 80 in-lbs].



Figure 41. Battery Stack and DC Bus Connector Lugs

Table 9. Battery Stack and DC Bus Connector Assignment

Name	Description	Connected to Device
Battery (-)	Negative terminal of battery stack	Battery stack
Battery (+)	Positive terminal of battery stack	Battery stack
DC Bus (-)	Negative terminal of DC bus	External equipment
DC Bus (+)	Positive terminal of DC bus	External equipment

A typical NUVG5-SSG-1500-350 installation capable of up to 350 A should use 4/0 AWG 90°C copper cable rated 1500 V DC or higher, based on Table 310.15(B)(17) of the NEC (Allowable Ampacities of Single-Insulated Conductors Rated Up to and Including 2000 Volts in Free Air). This should be evaluated on a per-project basis in accordance with site-specific conditions and local codes. The installer shall be responsible for installing cables in accordance with all applicable electrical codes.

In order to make the connection:

1. Feed the wire through the terminal cover
2. Strip the insulation
3. Crimp the lug
4. Screw the lug onto the terminal
5. Torque to the recommended specifications above
6. Slide the terminal cover onto the terminal



The battery stack terminals are always energized and should be handled as such.

Although the DC bus terminals are disconnected from the battery by the G5 Stack Switchgear unit’s contactors, the DC bus can still be energized by other components on the DC bus (e.g. PCS or other stacks). The DC bus terminals should always be treated as though they are energized.

A simple voltage check (i.e. across the positive and negative terminals) is not always sufficient, *especially* with grounded battery stacks. It is recommended to also check for voltage between each conductor and ground.

3.4. First Power-up

Once the G5 Cell Interface modules chain and the G5 Stack Switchgear are connected to the battery, the G5 Stack Switchgear can be powered.

Put the Service Disconnect switch in the **Operating** position. The power LED (green) will turn ON to indicate that the G5 Stack Switchgear is powered.

For more details on the Status LEDs, please refer to [Section 5.2, "Status LEDs"](#).



On initial power-up, it is common to see that the fault LED (red) is also ON. This indicates that a fault has been detected.

Once the Operator Interface is installed, the faults can be investigated and cleared. This will enable the G5 Stack Switchgear to connect the battery to the DC bus.



Nuvation Energy BMS relies on your system charger to charge the battery cells; do not leave your charger off while Nuvation Energy BMS is powered from the stack for prolonged periods of time. Nuvation Energy BMS should be shut down when the system is in storage to minimize the drain on the cells.



The G5 Cell Interface modules are powered from the cells and will continue to draw power even while the Battery Stack is disconnected from the DC Bus. For example, the G5 Cell Interface modules will continue to draw power even if the Nuvation Energy BMS has detected a low-voltage fault and opened contactors to disconnect the stack from the DC Bus. To protect the cells when the stack is not supervised, there are two options to significantly lower cell battery drain by the Nuvation Energy BMS:

1. Enabling Under Voltage Lockout (UVLO) which will shutdown down the Nuvation Energy BMS when cell or stack voltages reach critical levels. Refer to [Section 4.8.4, "UVLO Enable Config Switch Input"](#) for further operational and configuration details of UVLO.
2. Placing all stacks into Service Lockout which will prevent the scanning of all G5 Cell Interface. Refer to [Section 5.3.5, "Understanding the Service Lockout and Self Check"](#) for further details operational details of Service Lockout.

The G5 High-Voltage BMS can now be managed from a computer using the Operator Interface. Refer to the subsequent [Section 3.5, "Operator Interface Installation"](#) and [Section 5.3, "Using the Operator Interface"](#) for instructions on setup and using the Operator Interface.

3.5. Operator Interface Installation

3.5.1. Download and Install

The Operator Interface is used to access the G5 High-Voltage BMS. It must be installed on a local PC to access the BMS over a network connection.

Download

Visit <https://www.nuvationenergy.com/technical-resources> to download the latest version of the Operator Interface.

Install

Extract the contents of `bms-oi-<version>.zip` to a suitable location on your computer. To avoid overwriting other releases or files present in the same directory, it is recommended to extract the package to a folder with the same name as the package.

3.5.2. Setup PC Network Adapter

Ensure your computer is connected directly to the G5 Stack Switchgear via an Ethernet cable. You will need to configure the network adapter on your computer to match the settings on your G5 Stack Switchgear.

Identify the Battery Management System IP

By default, G5 Stack Switchgear is configured with a static IP address of 192.168.1.21 unless noted otherwise on a product label.

Identify the parts of the Battery Management System's IP Address

The IP address has two parts - the network ID and the host ID.



Figure 42. Parts of an IP address

Write down the network ID and host ID parts of the G5 Stack Switchgear's IP address.

Determine a valid IP address to assign to the PC

The Network ID for the PC IP address must be the same as the G5 Stack Switchgear. The Host ID number can be any number from 2 to 255 as long as it is not the same as the Host ID of the G5 Stack Switchgear. For example if the G5 Stack Switchgear IP address is 192.168.1.21, the IP address of the PC could be 192.168.1.12 or 192.168.1.49 or any 192.168.1.x where x is not 21.



If you have multiple stacks, note down the Host ID from the IP address of each stack's G5 Stack Switchgear. The Host ID number assigned to the PC must be

different from this list.

Setup the Static IP address on the PC

Instructions below are for a PC running Windows OS:

1. Go to Control Panel > Network and Sharing Center
2. Right-click your network adapter that connects to your G5 Stack Switchgear and select Properties
3. Click Internet Protocol Version 4 (TCP/IPv4) and click Properties

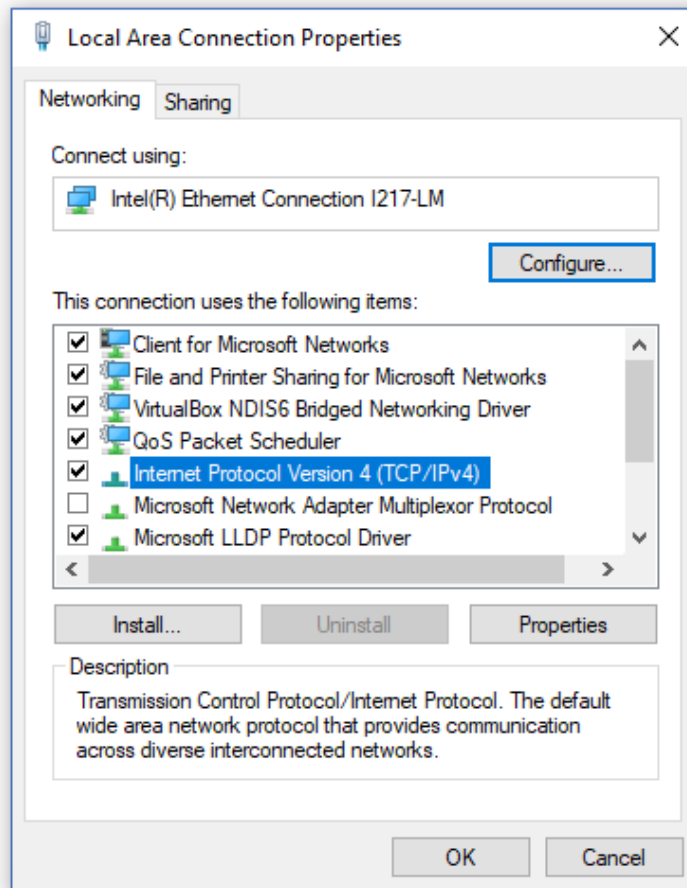

Figure 43. Network Adapter Properties on Windows.

4. Update your network adapter TCP/IPv4 settings to the following:
 - Static IP Address: The IP address must have the same Network ID as the G5 Stack Switchgear and a Host ID that isn't already in use.
 - Refer to the instruction above to determine a valid IP address for the PC.
 - Subnet Mask: 255.255.255.0
 - Default gateway: The Network ID must be the same as the G5 Stack Switchgear and the Host ID should be 1.

- For example, if the G5 Stack Switchgear IP address is 192.168.1.21, the gateway address would be 192.168.1.1

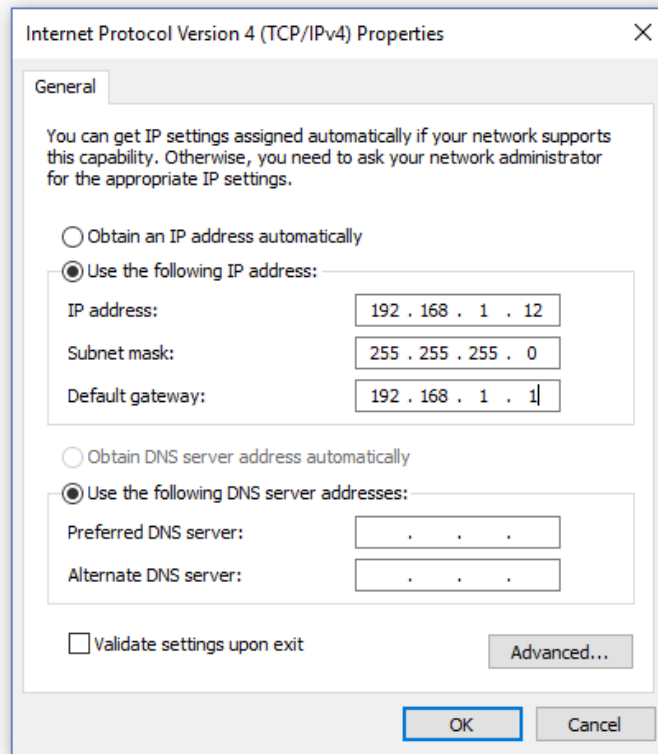

Figure 44. Network Adapter Settings on Windows

5. Ensure your computer is on the same network as your G5 Stack Switchgear.
 - You can connect an Ethernet cable directly between it and the network adapter of your PC.

3.5.3. Launch Operator Interface

Launch the Operator Interface by opening the Nuvation-Energy-Operator-Interface.html file in your web browser.



Browser Compatibility

The Operator Interface currently supports the most recent versions of Mozilla Firefox and Google Chrome. Other browsers such as Internet Explorer are not supported. Please install a supported browser before attempting to access the Operator Interface.

The Operator Interface will automatically attempt to connect to the default BMS IP (192.168.1.21) or the last successful BMS IP connection.

If the Operator Interface is unable to connect to the BMS at the assumed IP, a prompt to enter the BMS IP will be displayed. Ensure the computer IP address is on the same network as the BMS IP

address. See [Section 3.5.2, "Setup PC Network Adapter"](#).

Nuvation Energy BMS

BMS IP Address:

BMS Connection Timeout (seconds):

Save

3.6. Calibrate Nuvation Energy BMS

Nuvation Energy has pre-calibrated each G5 Stack Switchgear with its own gain and limit. Each unit will have its own set of calibrations which must be maintained when applying an upgrade or configuration update. Make sure to capture and record the calibration of each unit for this purpose.

If you have lost this calibration information, please contact support@nuvationenergy.com with the serial number(s) to retrieve this data.

4. Configuration Settings

G5 High-Voltage BMS is a highly customizable product. This section details the various configuration options available.

Configuration settings can be imported via a .config file or modified by using the 'Register Browser' in the Operator Interface. Imported settings can be either 'persisted' (retained after a reboot) or set to not persist. Changes made via the Register Browser are not persisted - i.e. they are not retained after a reboot.

4.1. Using Configuration Files

4.1.1. Generate Configuration File

The Operator Interface provides tools for importing and exporting configuration files to and from G5 Stack Switchgear as a way to set or retrieve the state of all configuration registers.



G5 High-Voltage BMS ships with a configuration file specific for the end application of the system and firmware version installed.



G5 High-Voltage BMS is a highly customizable product and the Configuration file lets you directly make changes to the BMS settings. However, serious problems might occur if the configuration settings are incorrectly modified.

If you need assistance with modifying the configuration, please contact support@nuvationenergy.com.

4.1.2. Import the Configuration File

The G5 High-Voltage BMS ships with a configuration file specific for its end application.

The following information is for advanced troubleshooting scenarios under the guidance of Nuvation Energy Product Support.

Backup existing Configuration

If your G5 High-Voltage BMS has been configured previously, please 'Export' your configuration file before importing a new one. The Export Configuration feature will generate configuration file with an alphabetical listing of all registers and their set values. Refer to [Section 5.3, "Using the Operator Interface"](#) for the following.

To Export a Configuration:

1. From the menu, select Service
2. Click Export Configuration
3. Save this .config file

Import new Configuration File

G5 High-Voltage BMS must be in Service Lockout before the file can be imported.

To Import a Configuration:

1. Unlock the Operator Interface by clicking the 'Lock' icon.
 - If the Operator Interface is password protected, please enter the password.
2. Navigate to 'Service' in the menu and click 'Enter Service Lockout'.
 - Please see [Section 5.3.5, "Understanding the Service Lockout and Self Check"](#) for more details.
3. Enable or Disable the Persist Configuration to BMS option.
 - **Enabling** this option tells G5 Stack Switchgear to persist the imported configuration file. If you are using known, good, configuration files you should check this box.
 - **Disabling** this option tells G5 Stack Switchgear to not persist the newly imported configuration file. On reboot, G5 Stack Switchgear will revert to the previous configuration file. This is useful when tweaking and testing configuration files. It allows you to recover from incorrect configuration settings by rebooting G5 Stack Switchgear
4. Click Import Configuration
5. Select the configuration file to use and click Open
6. A dialog indicating progress will pop-up



7. Wait until a dialog box appears with the configuration import result. It should indicate that the import was successful.

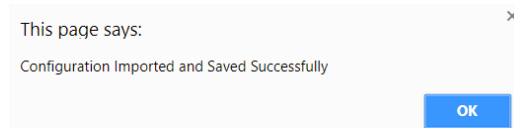

Backup imported Configuration Files

Please backup any imported or exported configuration file for future reference. G5 High-Voltage BMS does not store the .config file internally. Only the register values set in the configuration file are stored internally.

4.1.2.1. Configuration File Import Troubleshooting

Register Write failure error

During the configuration file import, if you receive a Register Write failure error, check to ensure you have valid entries in your configuration file.

For details on the various registers and their intended use, please refer to [Section 4, "Configuration Settings"](#).

Unable to exit Service Lockout

While exiting the service lockout, if a failure is reported, please see [Section 5.3.5, "Understanding the Service Lockout and Self Check"](#) for troubleshooting details.



If the failures persist, please submit a support ticket with as much detail as possible to support@nuvationenergy.com.

4.2. Background and Terminology

Terminology and technical concepts critical to the operation and configuration of Nuvation Energy BMS are presented in this section.

4.2.1. Register Data Model

Understanding the Register Data Model is key to understanding how to configure Nuvation Energy BMS.

Nuvation Energy BMS implements all data storage and processing using two important software building blocks.

Register

A register is the fundamental unit of data storage within the system. Each register has a unique name and associated type that defines how the value is interpreted. Registers range in size from as small as one byte up to as large as eight bytes.

Component

A component combines a set of related registers with processing rules that operate on those registers to implement a particular BMS function for the system. A given component may have many instances throughout the system. In this case, its associated registers will have the same number of instances.

Complex behavior within the system is achieved by connecting multiple components together, either through configuration or through hard-wired connections in the firmware itself.

Configuration for a system is completely determined by the state of all configuration registers present within the system. Configuration registers are persisted in non-volatile memory and are loaded automatically upon reset.

External protocols are implemented by mapping (and in some cases aggregating) the appropriate BMS registers to Modbus registers.

4.2.1.1. Index versus Location

Internally to Nuvation Energy BMS firmware, all register indexing is zero-based. That is, if multiple instances of the same register are present, the first instance is always indexed at zero. This

convention is reflected in all register expressions and configuration files.

Operator-facing tools such as Nuvation Energy BMS Operator Interface or the Modbus-based SunSpec Energy Storage Models use one-based location identifiers to refer to physical, countable entities.

For example, the location of the first cell within a stack is defined as Cell Interface 1, Cell 1—i.e. it is the first cell in the first G5 Cell Interface. The index of this first cell is defined as zero within the firmware.

4.2.1.2. Register Expressions

Registers are accessed by name in Nuvation Energy BMS tools and configuration. Each register also has a unique address that is used internally within the BMS.

Single Register Instance

This expression is used when assigning to or reading from a single register in the system and is of the form:

```
component_name.register_name
```

where:

- **component_name** is the name of the component within the system
- **register_name** is the name of the register within the component

Range of Register Instances

These expressions build on the single register references by adding an additional range expression in square brackets:

```
component_name[range_expression].register_name
```

The **range_expression** may take any of the following forms:

- **index** - A single instance of `component_name.register_name` at index. Note that `cell[0].voltage` is equivalent to `cell.voltage`.
- **start_index:end_index** - All instances from `start_index` through `end_index`. The expression `cell[0:3].voltage` expands into:

```
cell[0].voltage
cell[1].voltage
cell[2].voltage
cell[3].voltage
```

- **start_index:end_index:block_length** - All instances from `start_index` through `end_index` within a repeating block of `block_length` across all instances of the register. For example if there were N

instances of the register `cell.voltage`, the expression `cell[0:3:16].voltage` expands into:

```
cell[0].voltage
cell[1].voltage
cell[2].voltage
cell[3].voltage
cell[16].voltage
cell[17].voltage
cell[18].voltage
cell[19].voltage
cell[32].voltage
cell[33].voltage
cell[34].voltage
cell[35].voltage
...
cell[N-16].voltage
cell[N-15].voltage
cell[N-14].voltage
cell[N-13].voltage
```

- **start_index:end_index:block_length:block_count** - All instances from `start_index` through `end_index` within a repeating block of `block_length` repeated `block_count` times. The expression `cell[0:3:16:2].voltage` expands into:

```
cell[0].voltage
cell[1].voltage
cell[2].voltage
cell[3].voltage
cell[16].voltage
cell[17].voltage
cell[18].voltage
cell[19].voltage
```

In this case, only the first 2 blocks of 16 instances are included, rather than all blocks of 16 instances.

All Register Instances

A compact syntax can be used to expand to all instances of a given register within the system. The expression:

```
component_name[*].register_name
```

expands to all instances of **component_name.register_name** within the system. For example, the expression `cell[*].voltage` expands into:

```
cell[0].voltage
```

```
cell[1].voltage
cell[2].voltage
cell[3].voltage
cell[4].voltage
cell[5].voltage
cell[6].voltage
cell[7].voltage
cell[8].voltage
cell[9].voltage
cell[10].voltage
cell[11].voltage
cell[12].voltage
cell[13].voltage
cell[14].voltage
cell[15].voltage
cell[16].voltage
.
.
.
cell[N-3].voltage
cell[N-2].voltage
cell[N-1].voltage
```

where N is the total number of instances of the register `cell.voltage` within the system.

Register Address

In some cases, it is necessary to use the address of a register as a configuration value for another register in the system. This is required when assigning input and output pins to functions within the BMS, for example.

The expression:

```
@component_name.register_name
```

expands to the address of the register in the system. The single-instance range expression may be used for register addresses. For example:

```
@component_name[index].register_name
```

expands to the address of **component_name.register_name** at index in the system.

4.2.2. Units

A standard set of types/units has been adopted for use within Nuvation Energy BMS for the measurements and configuration settings. Unless otherwise noted, the units used within the firmware should be assumed as defined below.

Table 10. Standard Types and Units

Type	Units	Variable Type	Application
Address	none	uint32	BMS register address
Boolean	false=0, true=1	uint8	Logic value
Charge	mAh	int64	Depth of discharge and throughput
Count	number	uint32	A positive count of some event
Crc16	none	uint16	Used to verify persistent data
Current	mA	int32	Stack and pack currents
CurrentNano	nA	int32	Current in nano amps
Energy	Wh	uint64	Energy capacity of a stack
Farads	μFarads	uint32	Capacitance of cells
Float	value	float	Single precision floating point
Int8	value	int8	Signed 8 bit integer
Int16	value	int16	Signed 16 bit integer
Int32	value	int32	Signed 32 bit integer
Int64	value	int64	Signed 64 bit integer
Impedance	Ω	uint32	Resistance of a stack
ImpedanceMili	mΩ	uint32	Resistance of a stack
IpAddress	IP	uint32	IP4 address for a stack
LogLevel	none	uint32	Log level applied the BMS firmware
MicroOhms	μΩ	uint32	Resistance of a cell
Microseconds	μs	uint64	Time measurement or period
NanoVolts	nV	int32	Nano volt measurement
Percentage	%	uint8	Percentage of a full scale value (e.g. SoC)
PowerW	W	int32	Rated power of a stack
SoftwareId	enum	uint32	Enumeration for type of G4 Cell Interface
Temperature	°C	int16	Thermistor temperatures
String	none	char[8]	Storage for 8 characters
UInt8	value	uint8	Unsigned 8 bit integer
UInt16	value	uint16	Unsigned 16 bit integer
UInt32	value	uint32	Unsigned 32 bit integer
UInt64	value	uint64	Unsigned 64 bit integer
Voltage	mV	int32	Cell and stack voltages

Every register within the firmware has an associated type that defines the expected units for that register.



A negative value for *Current* represents a charge direction while a positive value represents a discharge direction with respect to the cell/stack. Some *Current* registers represent the magnitude of the current and are never negative in value.

These register exceptions include the following:

- `stack_current_limit.min_charge_current`
- `stack_current_limit.max_charge_current`
- `stack_current_limit.max_discharge_current`
- `stack_charge_status.hold_current`
- `stack_control.precharge_max_current`
- `stack_fault_precharge_over_current.thresh`

4.2.3. Storage Types

Each register in Nuvation Energy BMS can be one of five storage types.

Volatile

- Data that is not persisted across a system reset

Configuration

- Data that is persisted on the [service page](#) via loading a configuration file.

Persistent

- Data that is persisted and regularly saved

Factory

- Data that is persisted when requested and is typically set at the factory

Manufacturing

- Data that is persisted and saved at manufacturing time

These types of storage can be read directly from the Operator Interface *Registers* menu option as discussed in [Section 5.3.3.1, "Registers"](#).

4.2.4. Configuration File

Configuration is stored externally to Nuvation Energy BMS in a plain-text file. This file defines the state of configuration registers as required for a particular system.



The G5 High-Voltage BMS ships with a configuration file specific for its end application.

To update the configuration file, please contact support@nuvationenergy.com.

The Operator Interface provides tools for importing and exporting configuration files to and from Nuvation Energy BMS as a way to set or retrieve the state of all configuration registers.

The configuration file format is plain ASCII text with the following syntax:

- Any lines starting with a leading # are treated as comments.

- Each non-comment line is treated as a register assignment statement.

A register assignment takes on the form `register_expression = value` where:

- `register_expression` is one of the valid [Register Expressions](#) previously defined.
- `value` is either a numerical constant, quoted string, IP address, or a valid [Register Address](#).

Any standard text editor can be used to edit configuration files (e.g. Notepad++, etc.).



A configuration file cannot be used to configure the IP settings of a stack.

Stack IP configuration is detailed in the [Appendix E, BMS Network Configuration](#).



When a Battery Management System has been configured for [Factory Lockdown](#) there are a set of components that will have all their register protected from most write operations. Attempting to perform a write operation via a register addressing (for example using a [Digital Inputs](#)) will silently fail. Please refer to [Section 4.3.4, "Restricted Register Write Operations"](#) for further details.

4.3. Factory Lockdown

Factory Lockdown is a mechanism for users to lock registers with *Factory* storage type as read-only. This is typically used to protect safety related configurations for safety certification purposes.

4.3.1. Configuring Factory Registers

Factory registers can be configured in the same way normal configuration registers can be set. They can be set through the Operator Interface *Registers* menu option ([Section 5.3.3.1, "Registers"](#)) or applied by uploading a configuration file. Factory registers can only be configured when the system is not in *Factory Lockdown*.

4.3.2. Enabling Factory Lockdown

Factory Lockdown can be enabled by writing to specific registers from the Operator Interface. The user must follow the process below for the Nuvation Energy BMS to be considered factory-locked.

1. Ensure all factory registers are configured to their desired value
2. Write 1 to `sc_factory_lockdown.requested_state`
3. Write 1 to `sc_factory_persist.save`
4. Wait until `sc_factory_persist.save` is equal to 0
5. Verify `sc_factory_lockdown.actual_state` is equal to 1

4.3.3. Clearing Factory Lockdown

Contact Nuvation Energy (support@nuvationenergy.com) for assistance in unlocking a Factory Locked

G5 Stack Switchgear.

4.3.4. Restricted Register Write Operations

When *Factory Lockdown* has been enabled, all register writes are restricted through external interfaces (e.g. Modbus-TCP, HTTP) with some exceptions. A 'whitelist' of registers which can be written to when in *Factory Lockdown* and are excluded from write protection are listed in [Table 11, "Factory Lockdown Whitelist"](#).

Table 11. Factory Lockdown Whitelist

Register Name	Register Address (hexadecimal)
sc_op_state.requested_state	0x448C0
sc_boot.requested_state	0x383E0
stack_trigger_summary.clear_faults	0x203E9
stack_trigger_summary.clear_warnings	0x203EA
stack_factory_trigger_summary.clear_faults	0x364E9
stack_factory_trigger_summary.clear_warnings	0x364EA
sc_linkbus.cell_open_wire_manual_scan	0x113E3
sc_linkbus.diagnostics	0x113E9
stack_control.requested_state	0x313E1
stack_contactor[0].requested_value	0x193E1
stack_contactor[1].requested_value	0x193EF
stack_contactor[2].requested_value	0x193FC
sc_gpo[0].value	0x173E1
sc_gpo[1].value	0x173E6
sc_controller_wdt.expired	0x363E0
sc_controller_heartbeat.value	0x444E0
sc_persist.save	0x4800
sc_persist.load	0x4801
sc_persist.error	0x4802
sc_aux_persist.save	0x4818
sc_aux_persist.load	0x4819
sc_aux_persist.error	0x481A
sc_ci_persist.save	0x63D0
sc_ci_persist.load	0x63D1
sc_ci_persist.error	0x63D2
sc_val_persist.save	0x4820
sc_val_persist.load	0x4821
sc_val_persist.error	0x4822
cell_val_persist.save	0x4830

Register Name	Register Address (hexadecimal)
cell_val_persist.load	0x4831
cell_val_persist.error	0x4832
sc_network_cfg_persist.save	0x4840
sc_network_cfg_persist.load	0x4841
sc_network_cfg_persist.error	0x4842
sc_clock_err_stats.reset	0x29433
sc_stack_stat.reset	0x344E3
sc_linkbus_stat.reset	0x345E3
sc_rom_test_stat.reset	0x346E3
sc_ram_test_stat.reset	0x347E3
stack_balance_stat.update	0x44EE5
stack_soc.reset	0x163E3
stack_soc.reset_soc	0x163E4
stack_soc.reset_capacity	0x163E5
stack_soc.measured_capacity	0x163ED
stack_soc.adaptive_soc	0x163E8
stack_soc.accumulative_soc	0x163E7
ssg_gpi_error_fault.error	0x4CA80
ssg_gpi_error_warn.error	0x4CA70



Configuration storage typed registers can be written to and are exempt from this rule. Refer to [Section 4.2.3, “Storage Types”](#) for information on register storage types.

4.4. Battery Parameters

These following settings are used to configure State-of-Charge (SoC) and State-of-Health (SoH) algorithms for operation with a particular battery chemistry.

4.4.1. Stack Capacity

Battery stack capacity is defined as the total amount of charge that can be extracted from a battery stack when discharging from full to empty, assuming current limits are properly followed. Nominal (or design) capacity is configured as follows:

stack_soc.nominal_capacity

- Nominal capacity of the battery stack
- Set to the capacity that would correspond to a full discharge



The nominal capacity of the stack is identical to that of the cells used within the stack, where a cell may be one or more electro-chemical cells directly connected in

parallel. The actual capacity of the battery stack maybe less than this nominal capacity due to imbalances in SoC and capacity fade of the cells with usage. Correct configuration of the nominal capacity is essential for accurate SoC and SoH estimation.

4.4.2. Stack Cycle Count

In addition to the nominal capacity, the nominal cycle count for the battery stack is required for SoH estimation based upon cycle count.

`stack_soc.nominal_cycle_count`

- Set to the expected cycle life of the battery stack assuming full discharge cycles at the configured maximum operating current
- Set to zero to ignore cycle count for SoH

4.4.3. State-of-Health

The State-of-Health (SoH) is a value that can be used to describe the battery's current performance relative to its performance at beginning of life. Nuvation Energy BMS estimates SoH by using one or both of the following two metrics:

1. **Cycle count:** SoH for a specific cell can be defined as the ratio of the number of equivalent cycles to the nominal cycle count. At the stack level, the SoH will be the minimum of the cell SoH values.
2. **Battery capacity:** Capacity based SoH can be defined as the ratio of the current measured capacity to the nominal capacity value. Note that this SoH value will also include charge imbalance.

There are two ways State-of-Health can be configured using the above two metrics:

1. Capacity based SoH:
 - a. Configure the nominal capacity as describe in the [battery capacity](#) section.
 - b. Set the `stack_soc.nominal_cycle_count` register to zero.
2. Capacity and cycle count based SoH:
 - a. Configure both the [battery capacity](#) and [cycle count](#).
 - b. The SoH estimate will be the minimum of the stack capacity SoH and the stack cycle count SoH.



Currently, we cannot configure SoH based only on cycle count. SoH will always have a capacity based component to it.

4.4.4. State of Charge (SoC)

The state of charge of a battery is a measure of the percentage of charge contained in the battery that is available for discharge. The BMS can be configured to measure the state of charge using two different methods:

1. **Accumulated SoC:** Continuously measures and accumulates the charge that is charged/discharged to/from the battery.
2. **Adaptive SoC:** Augments the accumulated measurements with an adaptive SoC algorithm. This latter technique compensates for errors due to integration over long periods of time and for factors such as self discharge which can not be directly measured by a BMS. The algorithm requires a configuration of the [open circuit voltage](#) for the battery.

The following parameters are used to select and enable which state of charge for the Nuvation Energy BMS.

Table 12. Current Full Condition Configuration

Register	Type	Units	Description
stack_soc.enable	config	bool	Enables the state of charge measurement when set to one. Applies to both SoC techniques
stack_soc.output_select	config	enum	Selects which technique of state of charge is used for output on the following registers. Zero selects the accumulated SoC measurement and one selects the adaptive SoC algorithm.
stack_soc.soc	output	percentage	The current state of charge of the battery
stack_soc.dod	output	mAhr	The current depth of discharge of the battery



The adaptive state of charge algorithm does require more detailed configuration settings for proper use. Please contact support@nuvationenergy.com for help in configuring this algorithm for your battery chemistry. This algorithm is not currently recommended for LFP chemistries.



The SunSpec Energy Storage Models Modbus point definition for SoC and DoD uses the data from the registers noted above for output.

The end limits for the state of charge (i.e. 0% and 100%) are defined by the full and empty conditions of a battery. The following subsections provide details on these end conditions and how they are configured.

4.4.4.1. Battery Empty Condition

Nuvation Energy BMS supports the definition of the empty condition using either or both min/max and average cell voltages, as configured using the following registers.

stack_soc.vempty

- Defines fully discharged minimum cell voltage for operation
- Set as per application requirements, or set to zero to disable

stack_soc.vemptyavg

- Defines fully discharged average cell voltage for operation
- Set as per application requirements, or set to zero to disable

When discharging near the bottom of the battery, if the empty conditions are not met the battery will remain at 1% SoC.



For battery chemistries that do not tolerate over-discharge, the empty conditions are typically applied against the minimum cell voltages. `stack_soc.vemptyavg` should be set to 0 mV for most applications.



These voltage settings must be carefully aligned with the minimum [Cell Voltage Thresholds](#) and [Stack Voltage Thresholds](#) for proper SoC operation.

4.4.4.2. Battery Full Condition

A battery can reach the full condition while charging (i.e. when the BMS reads negative current measurements) Nuvation Energy BMS supports the definition of the full condition using a combination of cell voltage and battery current measurements. This condition is configurable using the following register settings.

`stack_soc.vfull`

- Defines fully charged maximum cell voltage for operation
- Set as per application requirements, or set to zero to disable

`stack_soc.vfullavg`

- Defines fully charged average cell voltage for operation.
- Set as per application requirements, or set to zero to disable.

`stack_soc.ifull`

- Defines the largest negative current before the battery is considered full.
- Value must be negative to represent a current in the charge direction.
- Set to a large negative value (default) if this condition is not applicable.

`stack_charge_status.hold_current`

- Defines the upper bound for the current full condition.
- Configured as a positive value.
- Software will use the negative value of this setting for the full condition.
- Should be larger than the noise measurement of the current.

`stack_soc.ifull_period`

- Defines the period a current must between the prior thresholds before the full current condition is met.
- Configured as a positive value in microseconds.
- Set to a value of zero if no period is desired.

A battery is full (reaches 100% SoC) if all three of the following conditions are met:

1. The full voltage condition is met (either/both maximum or average setting).

2. The battery current is between the full current threshold and the negative hold current.
3. The battery current is maintained between the prior thresholds for the duration of the ifull period.

For example, assume the following:

```
vfull      = 3600 mV
vfullavg   = 0
ifull      = -1000 mA
hold_current = 5 mA
ifull_period = 1000000 microseconds
```

The full condition would be met when the first cell voltage equals or was greater than 3.6 V AND when the current was between -1000 and -5 mA for a duration of one second.

When charging at the top end of the battery, if the full conditions are not met the battery will remain at 99% SoC.



For battery chemistries that do not tolerate overcharge and make use of electrical balancing circuits to keep cells balanced (e.g. Lithium-Ion), the full conditions are typically applied against the maximum cell voltages. But for chemistries that make use of overcharge during the charging process as a way to balance the stack (e.g. lead acid), the empty conditions are typically applied against the average cell voltage.



These voltage settings must be carefully aligned with the maximum [Cell Voltage Thresholds](#) and [Stack Voltage Thresholds](#) for proper SoC operation.

4.4.5. Open Circuit Voltage Curve

Nuvation Energy BMS supports the use of an open-circuit voltage (OCV) table for the battery cells. The component `stack_ocv_lut` stores the voltages unique for each SoC percentage (total of 101 entries). The first table entry represents 0 percent and the last entry represents 100 percent. The voltages must be consistent with the defined the cell voltage range of [empty to full](#).

The OCV curve can be used to estimate the SoC of a stack when it is at rest. Contact support@nuvationenergy.com for details on how to perform this estimation.

4.4.6. Cell Resistance Estimation

The Nuvation Energy BMS can be configured to estimate the per cell resistance of every installed cell during charge/discharge usage. To learn more about this feature and how to configure and use it, please contact support@nuvationenergy.com.

4.4.7. Nameplate Information

Nuvation Energy BMS can be configured to display nameplate information about the battery stack.

`stack_nameplate.label0`

- First 8 characters of the battery stack's name which will be displayed as a banner on the Operator Interface

`stack_nameplate.label1`

- Next 8 characters of the battery stack's name after `stack_nameplate.label0`

`stack_nameplate.label2`

- Next 8 characters of the battery stack's name after `stack_nameplate.label1`

`stack_nameplate.label3`

- Next 8 characters of the battery stack's name after `stack_nameplate.label2`

`stack_nameplate.battery_type`

- Type of battery, corresponding to SunSpec (Draft 3) model 801 Point: `BatTyp`

`stack_nameplate.energy_capacity`

- The nameplate energy capacity of the battery stack in Wh, corresponding to SunSpec (Draft 3) model 801 Point: `WHRtg`

`stack_nameplate.max_charge_rate`

- The nameplate maximum rate of energy transfer into the battery stack in W, corresponding to SunSpec (Draft 3) model 801 Point: `WMaxChaRte`

`stack_nameplate.max_discharge_rate`

- The nameplate maximum rate of energy transfer out of the battery stack in W, corresponding to SunSpec (Draft 3) model 801 Point: `WMaxDisChaRte`

`stack_nameplate.max_soc`

- The nameplate maximum state of charge expressed as a percentage, corresponding to SunSpec (Draft 3) model 801 Point: `SoCnPMaxPct`

`stack_nameplate.min_soc`

- The nameplate minimum state of charge expressed as a percentage, corresponding to SunSpec (Draft 3) model 801 Point: `SoCnPMinPct`

4.5. Stack Topology

Configuring the battery stack topology requires that the following be specified:

- Which cell voltage taps are actually connected to cells
- Which thermistor inputs are actually connected to thermistors

4.5.1. Cell Inputs

The G5 Cell Interface modules may be connected to fewer cells than the maximum supported number of cell inputs.

The following registers are used to indicate which cells are actually present in the system. The index `n` is the zero-based index of the cell input.

`cell[n].installed`

- Indicates a cell is physically connected
- Set to 1 if connected
- Set to 0 if not connected

To configure the G5 Cell Interface - 24 channel for G5 Stack Switchgear, the following register configurations must be applied.

Table 13. CI-24 Configuration Registers

Register	Value	Description
<code>sc_linkbus[0].cicount</code>	0 to 20	Number of CI-24 in the link-bus chain
<code>sc_linkbus[0].softwareid</code>	32	Identifies the CI as a CI-24
<code>sc_linkbus[0].powermode</code>	0	Selects both link-bus and refernce voltage as off
<code>cell[0:23:24:20].installed</code>	0 or 1	Cells are installed in repeated groups of 24
<code>therm[0:7:8:20].installed</code>	0 or 1	Thermistors are installed in repeated groups of 8

4.5.2. Thermistor Inputs

The G5 Cell Interface modules may be connected to fewer than the maximum supported number of thermistors. The following registers are used to indicate which thermistors are actually present in the stack. The index *n* is the zero-based index of the thermistor input.

`therm[n].installed`

- Indicates a thermistor is physically connected
- Set to 1 if connected
- Set to 0 if not connected

Thermistor indexing is statically assigned in such a way that `therm[0]` always refers to the first thermistor on the first G5 Cell Interface in the Link Bus chain.

When using multiple G5 Cell Interface modules, `therm[8]` refers to the first thermistor in the second G5 Cell Interface in the Link Bus chain, `therm[16]` refers to the first thermistor in the third G5 Cell Interface in the Link Bus chain, and so on.

4.6. Operational Limits

The operational limits of a battery stack are captured in the form of voltage, temperature, and current thresholds. These thresholds must be set correctly for your battery cells and DC bus system so that the BMS can:

1. Control current during charging and discharging to keep the battery within normal operating limits.
2. Warn operators and external systems if the battery is not within normal operating limits
3. Disconnect the battery from the DC bus under a fault condition if the battery is approaching

unsafe limits

Nuvation Energy BMS can either be in an operating or non-operating zone. The operating zone is also known as the *All Clear* zone while the non-operating zone is further divided into the *Warning* and *Fault* zones. All three zones are illustrated below graphically.

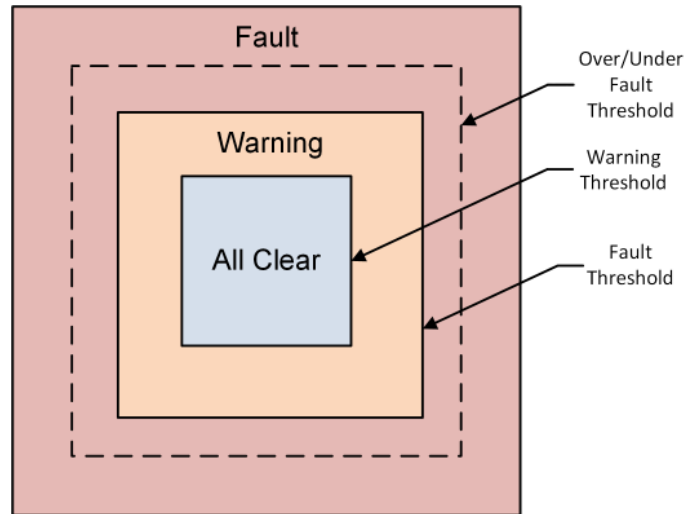

Figure 45. Battery Management System Zones

All Clear

- The *All Clear* zone represents the subset of all system states that can be reached under normal, fully controlled operation. With proper configuration and functional control, a system should never leave this zone.

Warning

- The *Warning* zone describes the region where the battery cells are not within their normal operating limits and Nuvation Energy BMS is taking action to try and bring the system back into the operating zone.

Fault

- The *Fault* zone describes the region where the battery cells are approaching unsafe limits. There are two thresholds within this zone: the *Fault Threshold* and the *Over/Under Fault Threshold*. At least one of the two thresholds should be enabled.
 - At the *Fault Threshold*, Nuvation Energy BMS will gracefully disconnect the battery from the DC bus and shut down the inverter. When the battery cells return to an operable state, Nuvation Energy BMS can be configured to automatically reconnect the battery to the DC bus.
 - At the *Over/Under Fault Threshold*, Nuvation Energy BMS will disconnect the battery cells as quick as possible. An explicit user action is required to bring the system back into an operating state at this point. These faults must be enabled for functional safety compliance for UL 1973 or UL 9540.

4.6.1. Triggers

The fundamental building block used to define thresholds throughout Nuvation Energy BMS are

trigger components. There are four types of trigger components, each described in the following sections.

4.6.1.1. Basic Triggers

A Basic Trigger is the most fundamental type of trigger in Nuvation Energy BMS. This trigger is latching meaning a tripped trigger will not self-clear when the trigger condition is cleared. The trigger will remain tripped until explicitly cleared through an external request via the Operator Interface or a supported protocol.

`trigger_name.thresh`

- The input must meet or exceed this threshold to trip the trigger.

`trigger_name.disabled`

- Set to 0 to enable the trigger
- Set to 1 to disable the trigger

4.6.1.2. Boolean Triggers and Standalone Triggers

Boolean and Standalone Triggers are specific types of Basic Triggers where the trigger is tripped based on either a 1 or 0 value. The two triggers are identical except for how they are tripped. Both triggers are latching. The following register is used to configure these types of triggers.

`trigger_name.disabled`

- Set to 0 to enable the trigger
- Set to 1 to disable the trigger

4.6.1.3. Hysteresis Triggers

A Hysteresis Trigger provides a means of hysteresis to the triggering condition. This trigger can be configured to be latching or non-latching. The following registers are used to configure this type of trigger.

`trigger_name.thresh`

- The input must meet or exceed this threshold to trip the trigger

`trigger_name.time_hyst`

- The elapsed time that the input must meet or exceed the threshold in order to trip the trigger
- Set to 0 to configure a trigger that trips instantly

`trigger_name.end_time_hyst`

- The elapsed time that the input must recover (i.e. remain below the threshold) before the trigger will clear
- Set to 0 to configure a trigger that clears instantly
- Set to > 0 to configure a trigger that clears after the defined period of time

`trigger_name.latched`

- Set to 1 for latching trigger behavior
- Set to 0 for non-latching trigger behavior

`trigger_name.disabled`

- Set to 0 to enable the trigger
- Set to 1 to disable the trigger

4.6.1.4. User-Defined Triggers

A user-defined trigger provides a separate way to create a high/low signal based on BMS measurements. The user-defined triggers are not connected into any of the prior warning or fault reporting and operate independently. A user-defined trigger will not open contactors when triggered. Once configured, the triggered state of any user-defined trigger could be directed to a [General Purpose Output](#) or [Configurable Modbus](#) point for external control/notification outside of Nuvation Energy BMS.

A user-defined trigger is configured identically as the [hysteresis trigger](#).

All user defined triggers have the following two naming formats:

- `stack_trig_<measurement>_<condition>`
- `ssg_trig_<measurement>_<condition>`

4.6.1.5. Externally Activated Fault and Warning

At times there is a need for the G5 High-Voltage BMS to react to events external to itself. For example if a ground fault detection failure was determined in the stack, it would be desirable for that external detection to disconnect the stack. The Nuvation Energy BMS has the ability to configure a fault and/or warning that can be externally triggered using one of the two [GPI inputs](#).

The components that manage the fault and warning are as follows:

- `ssg_fault_gpi`
- `ssg_warn_gpi`

These fault and warning components are derived from the hysteresis trigger and has the same [configuration options](#) available to them. The GPI used to direct the fault/warning signal into the BMS must be configured to write its output to one of these registers.

- `ssg_gpi_error_fault[0].error`
- `ssg_gpi_error_warn[0].error`

4.6.2. Cell Voltage Thresholds

The following diagram illustrates how cell voltage trigger thresholds are configured in typical applications.

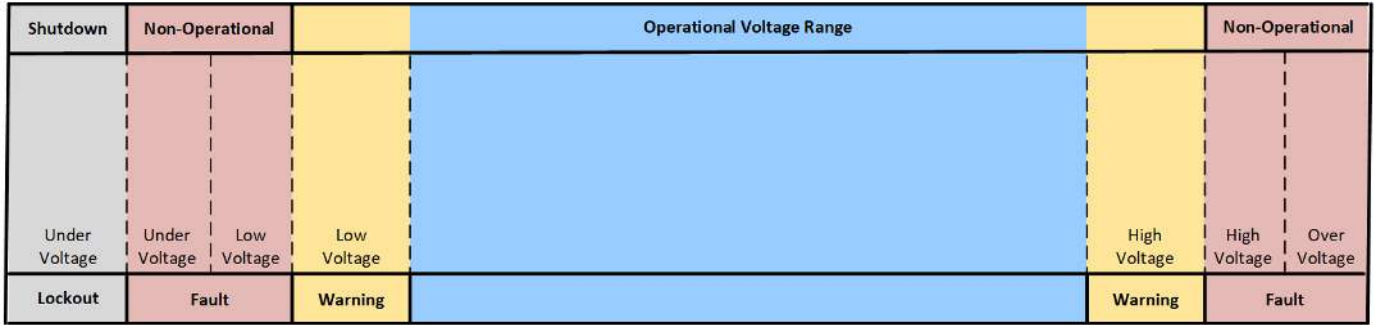

Increasing Voltage

Figure 46. Typical Arrangement of Cell Voltage Thresholds

These thresholds also affect the current limits of the system as shown below.

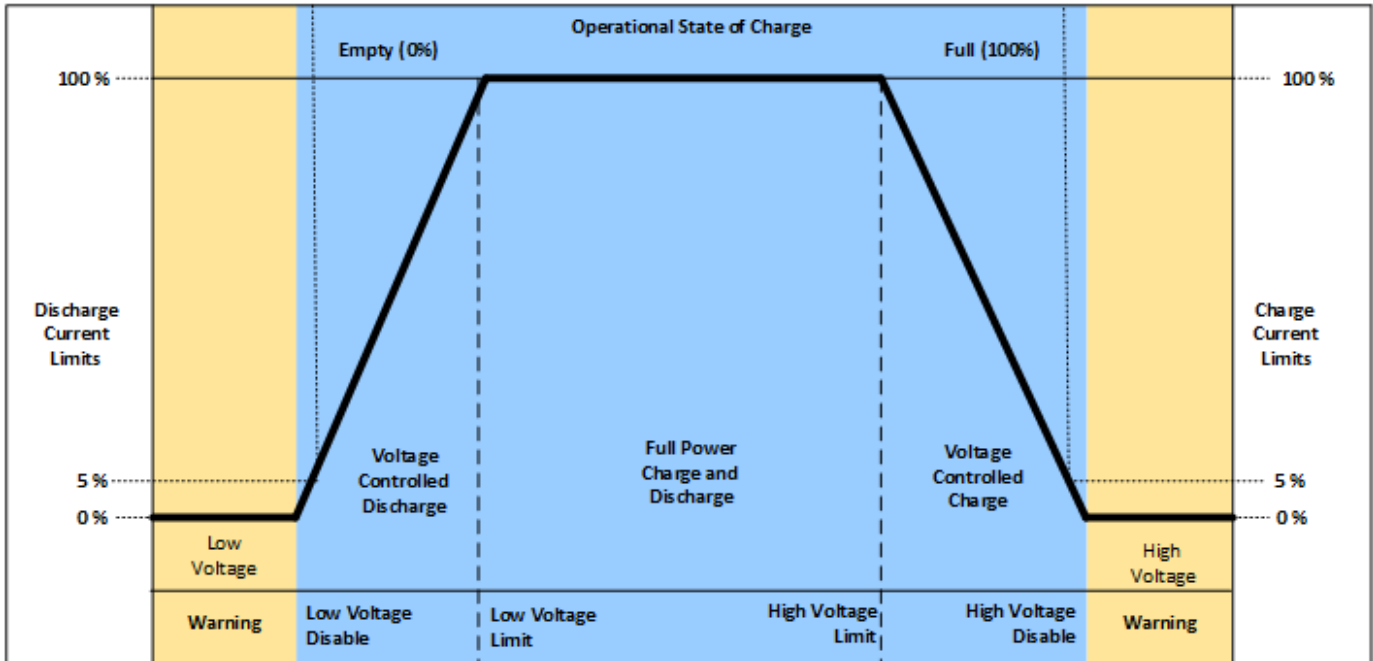

Figure 47. Typical Arrangement of Cell Voltage Current Limits

Most systems will make use of thresholds configured in the following order of decreasing cell voltage.

Table 14. Cell Voltage Operational Limits

Register	Setting
stack_fault_cell_over.thresh	The limit within the fault zone above which an explicit user operation is required to bring the system back into an operating state.
stack_fault_cell_hi.thresh	The upper limit of the warning zone as per cell specifications. Set just below stack_fault_cell_over.thresh to allow a self-clearing range within the fault zone.

Register	Setting
stack_warn_cell_hi.thresh	The upper limit of the operating zone. Set just above stack_current_limit.voltage_cell_max.
stack_current_limit.voltage_cell_max	The voltage at which charge limits approach 0%. Set just above stack_soc.vfull.
stack_current_limit.voltage_cell_high	The voltage at which charge current limits are reduced from 100%. Set as per application requirements.
stack_current_limit.voltage_cell_low	The voltage at which discharge current limits are reduced from 100%. Set as per application requirements.
stack_current_limit.voltage_cell_min	The voltage at which discharge limits approach 0%. Set just below stack_soc.vempty.
stack_warn_cell_lo.thresh	The lower limit of the operating zone. Set just below stack_current_limit.voltage_cell_min.
stack_fault_cell_lo.thresh	The lower limit of the warning zone as per cell specifications. Set just above stack_fault_cell_under.thresh to allow a self-clearing range within the fault zone.
stack_fault_cell_under.thresh	The limit within the fault zone below which an explicit user operation is required to bring the system back into an operating state.
stack_uvlo_cell_voltage.thresh	The under-voltage lockout threshold for system shutdown.



The under-voltage lockout feature can trigger the BMS to shut down when a cell voltage drops below this level. For more information on UVLO, refer to [Under-Voltage Lockout](#).

stack_fault_cell_over.thresh may or may not be different from stack_fault_cell_hi.thresh, depending upon system requirements. For example, if a battery system is expected to implement self-clearing (non-latching) faults during operation, the stack_fault_cell_hi.thresh must be set slightly below stack_fault_cell_over.thresh. This allows the stack_fault_cell_hi trigger to prevent the stack_fault_cell_over trigger from engaging, which would require an explicit clear action. If the stack_fault_cell_over.thresh and stack_fault_cell_hi.thresh are identical, it is impossible to implement self-clearing behavior on high voltage conditions. The same applies to under-voltage conditions.

The stack_fault_cell_[over/under] or the stack_fault_cell_[hi/lo] trigger can be disabled if only one behavior is necessary. The stack_fault_cell_[over/under] triggers must be enabled for safety compliance to UL 1973 or UL 9540.

User-defined triggers are also available for high and low cell voltages.

Table 15. User-Defined Cell Voltage Triggers

Register	Setting
stack_trig_cell_hi.thresh	User-defined high cell voltage trigger
stack_trig_cell_lo.thresh	User-defined low cell voltage trigger

4.6.3. Thermistor Temperature Thresholds

Separate configuration thresholds are provided for charging and discharging as many cells have different temperature limits in these two modes of operation. Charge triggers will only trip while the stack is charging, while discharge triggers will only trip while the stack is discharging or resting.

The following diagrams illustrates how temperature trigger thresholds are configured in typical applications.

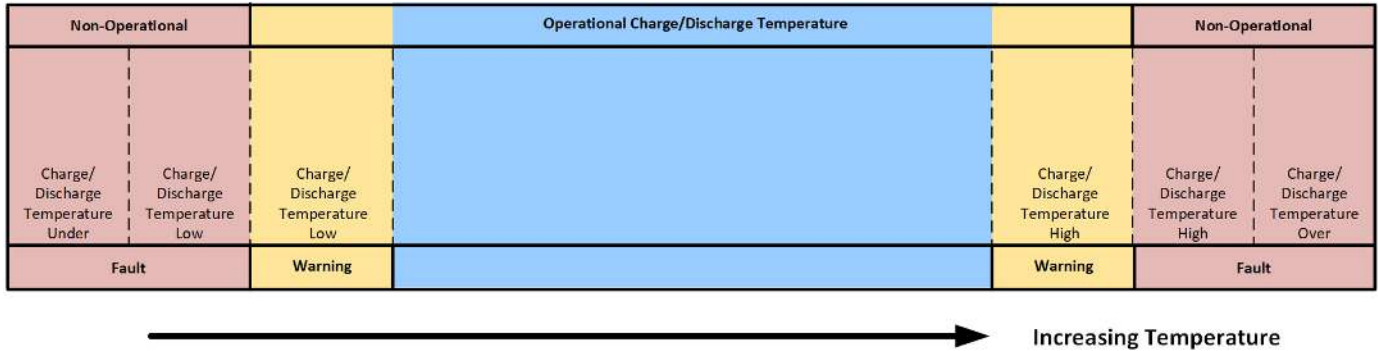

Figure 48. Typical Arrangement of Temperature Thresholds

These thresholds also affect the current limits of the system as shown below.

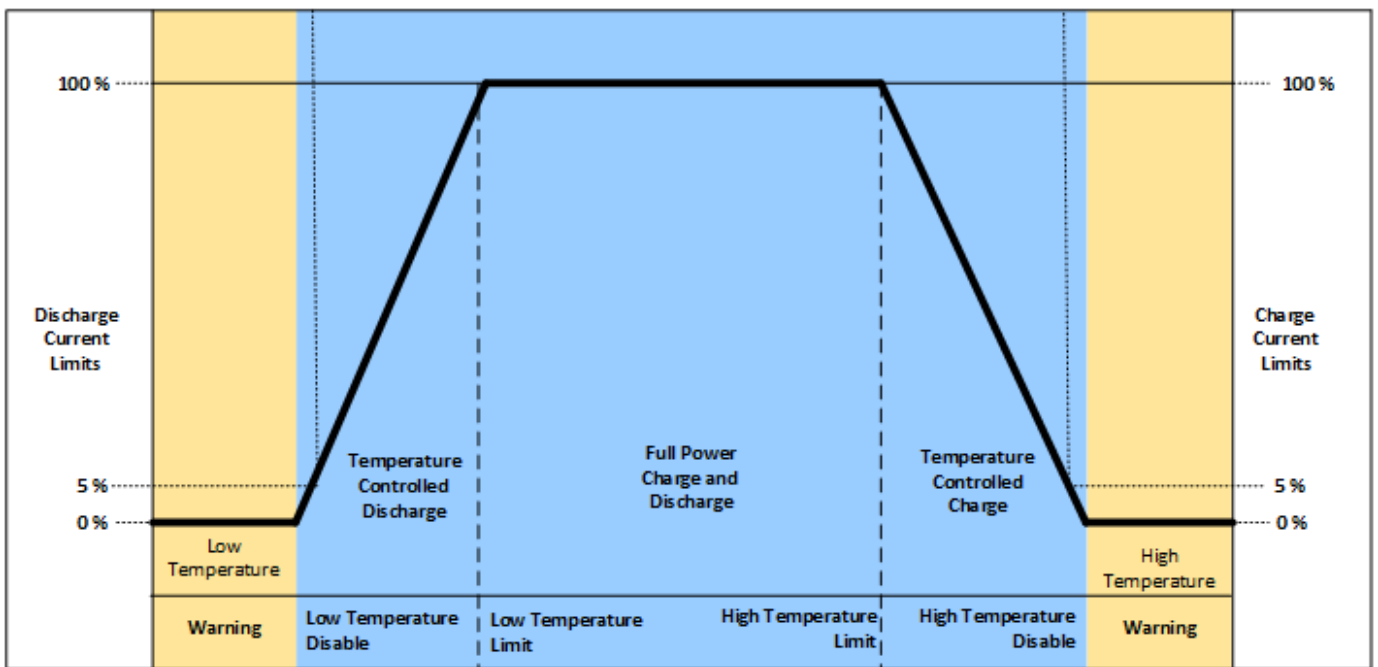

Figure 49. Typical Arrangement of Temperature Current Limits

Most systems will make use of thresholds configured in the following order of decreasing thermistor temperature.

Table 16. Charge Temperature Operational Limits

Register	Setting
stack_fault_charge_therm_over.thresh	The limit within the fault zone above which an explicit user operation is required to bring the system back into an operating state.
stack_fault_charge_therm_hi.thresh	The upper limit of the warning charging zone as per cell specification.
stack_warn_charge_therm_hi.thresh	The upper limit of the operating charging zone. Set just above stack_current_limit.temperature_charge_max.
stack_current_limit.temperature_charge_max	The temperature at which current limits approach 0% during charging.
stack_current_limit.temperature_charge_high	The temperature at which current limits are reduced from 100% during charging.
stack_current_limit.temperature_charge_low	The temperature at which current limits are reduced from 100% during charging.
stack_current_limit.temperature_charge_min	The temperature at which current limits approach 0% during charging.
stack_warn_charge_therm_lo.thresh	The lower limit of the operating charging zone. Set just below stack_current_limit.temperature_charge_min.
stack_fault_charge_therm_lo.thresh	The lower limit of the warning charging zone as per cell specification.
stack_fault_charge_therm_under.thresh	The limit within the fault zone below which an explicit user operation is required to bring the system back into an operating state.

Table 17. Discharge Temperature Operational Limits

Register	Setting
stack_fault_discharge_therm_over.thresh	The limit within the fault zone above which an explicit user operation is required to bring the system back into an operating state.
stack_fault_discharge_therm_hi.thresh	The upper limit of the warning discharging zone as per cell specification.
stack_warn_discharge_therm_hi.thresh	The upper limit of the operating discharging zone. Set just above stack_current_limit.temperature_discharge_max.
stack_current_limit.temperature_discharge_max	The temperature at which current limits approach 0% during discharging.
stack_current_limit.temperature_discharge_high	The temperature at which current limits are reduced from 100% during discharging.
stack_current_limit.temperature_discharge_low	The temperature at which current limits are reduced from 100% during discharging.
stack_current_limit.temperature_discharge_min	The temperature at which current limits approach 0% during discharging.
stack_warn_discharge_therm_lo.thresh	The lower limit of the operating discharging zone. Set just below stack_current_limit.temperature_discharge_min.
stack_fault_discharge_therm_lo.thresh	The lower limit of the warning discharging zone as per cell specification.

Register	Setting
stack_fault_discharge_therm_under.thresh	The limit within the fault zone below which an explicit user operation is required to bring the system back into an operating state.

The temperature charge and discharge thresholds can be configured in a similar manner to how the cell voltage thresholds ([Section 4.6.2, "Cell Voltage Thresholds"](#)) are configured.

User-defined triggers are also available for high and low thermistor temperature during both charge and discharge.

Table 18. User-Defined Charge Temperature Triggers

Register	Setting
stack_trig_charge_therm_hi.thresh	User-defined threshold for charge high temperature trigger.
stack_trig_charge_therm_lo.thresh	User-defined threshold for charge low temperature trigger.

Table 19. User-Defined Discharge Temperature Triggers

Register	Setting
stack_trig_discharge_therm_hi.thresh	User-defined threshold for discharge high temperature trigger.
stack_trig_discharge_therm_lo.thresh	User-defined threshold for discharge low temperature trigger.

4.6.4. Stack Current Thresholds

The following diagrams illustrate how current trigger thresholds are configured in typical applications.

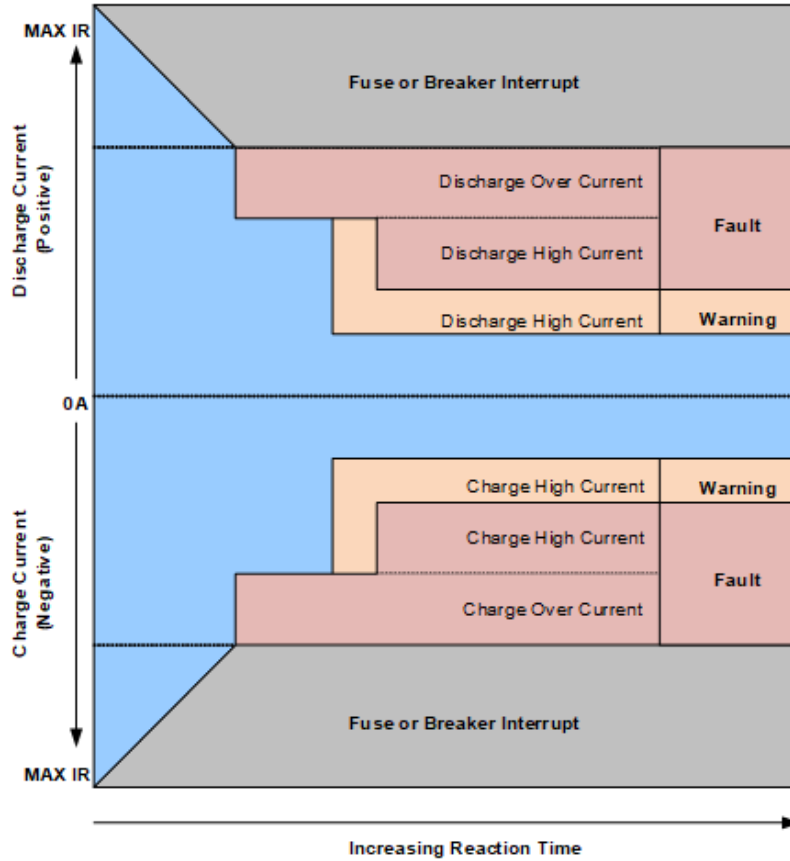

Figure 50. Typical Arrangement of Current Thresholds

The stack current thresholds are used to define the limits of the operating zone and non-operating zone for charge and discharge currents. These limits must factor in the specifications of the battery cells as well as the limits of any DC current-carrying paths in the stack.

Table 20. Stack Current Operational Limits

Register	Setting
stack_fault_charge_current_over.thresh	The limit within the fault zone above which an explicit user operation is required to bring the system back into an operating state.
ssg_fault_bus_charge_current_over.thresh	The limit within the fault zone above which an explicit user operation is required to bring the system back into an operating state, as measured on the DC bus.
stack_fault_charge_current_hi.thresh	The limit of the warning charging zone as per cell specification and stack design limits.
stack_warn_charge_current_hi.thresh	The limit of the operating charging zone as per application requirements.
stack_warn_discharge_current_hi.thresh	The limit of the operating discharging zone as per application requirements.
stack_fault_discharge_current_hi.thresh	The limit of the warning discharging zone as per cell specification and stack design limits.

Register	Setting
stack_fault_discharge_current_over.thresh	The limit within the fault zone below which an explicit user operation is required to bring the system back into an operating state.
ssg_bus_fault_discharge_current_over.thresh	The limit within the fault zone below which an explicit user operation is required to bring the system back into an operating state, as measured on the DC bus.

The stack current thresholds can be configured in a similar manner to how the cell voltage thresholds ([Section 4.6.2, “Cell Voltage Thresholds”](#)) are configured. The stack_fault_[charge/discharge]_current_hi faults are typically configured with a small amount of trip time hysteresis (e.g. approximately 100–200 ms).

Concurrently, Nuvation Energy BMS includes separate triggers which derive from [Section 5.1.1.2.2, “Continuous and Maximum Current Ratings”](#).

Table 21. G5 Stack Switchgear Continuous and Maximum Current Operational Limits

Register	Setting
ssg_fault_charge_current_hi.thresh	The maximum rated continuous charge current of the G5 Stack Switchgear.
ssg_fault_charge_current_hi.time_hyst	Time in microseconds for which the G5 Stack Switchgear can operate above the maximum rated continuous charge current before opening the contactors.
ssg_fault_charge_current_over.thresh	The absolute maximum rated charge current of the G5 Stack Switchgear.
ssg_fault_discharge_current_hi.thresh	The maximum rated continuous discharge current of the G5 Stack Switchgear.
ssg_fault_discharge_current_hi.time_hyst	Time in microseconds for which the G5 Stack Switchgear can operate above the maximum rated continuous discharge current before opening the contactors.
ssg_fault_discharge_current_over.thresh	The absolute maximum rated discharge current of the G5 Stack Switchgear.

User-defined triggers are also available for charge and discharge currents.

Table 22. User-Defined Stack Current Triggers

Register	Setting
stack_trig_charge_current_hi.thresh	User-defined charge current trigger.
stack_trig_discharge_current_hi.thresh	User-defined discharge current trigger.



Charge current thresholds are specified as negative values and discharge current thresholds are specified as positive values.

4.6.5. Stack Voltage Thresholds

The following diagrams illustrate how stack voltage trigger thresholds are configured in typical

applications.

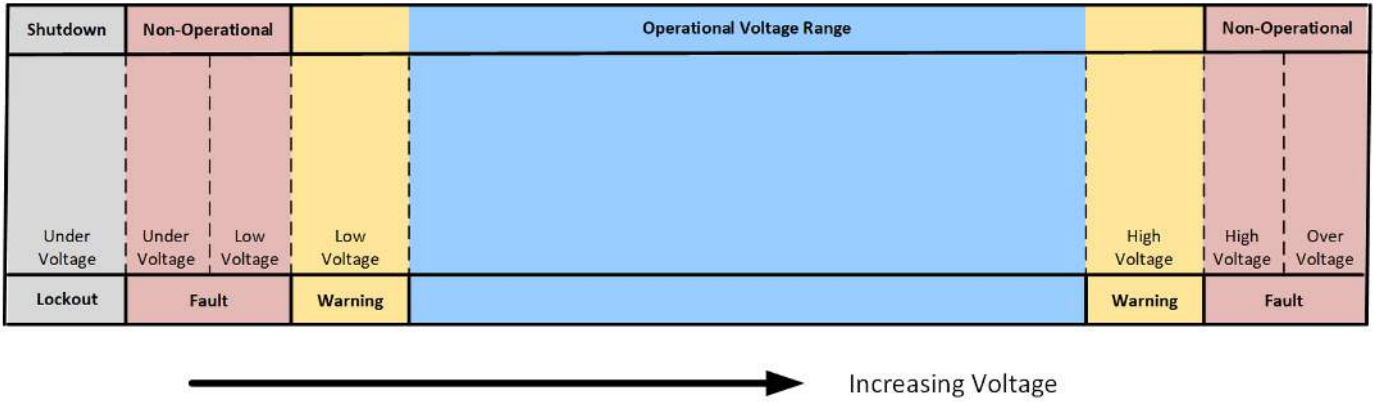

Figure 51. Typical Arrangement of Stack Voltage Thresholds

These thresholds also affect the current limits of the system as shown below.

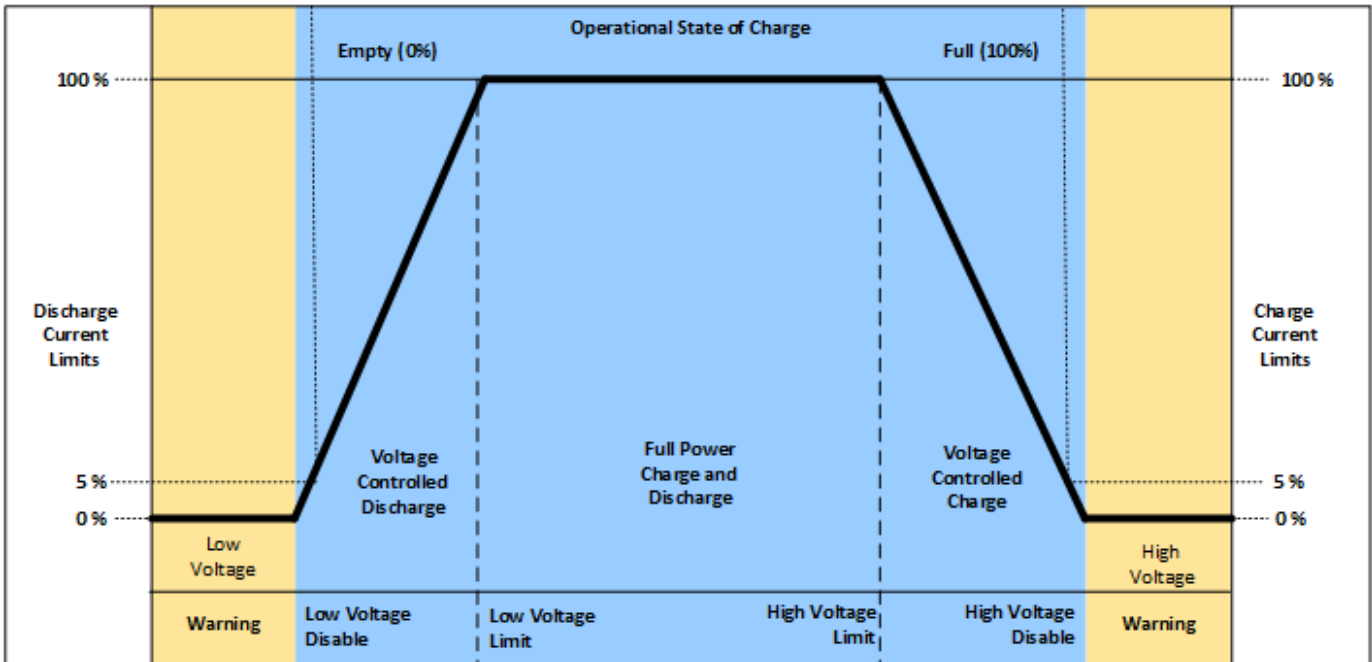

Figure 52. Typical Arrangement of Stack Voltage Current Limits

Stack voltage thresholds are used to define the operating voltage limits of the overall battery stack design. These thresholds are used to enforce the design limits of the battery stack or DC bus as a whole. For example, it may be necessary to limit the overall stack voltage within a certain limited range to maintain compatibility with a specific charger or inverter. Stack voltage limits also are used to ensure that average cell voltage is maintained within specified limits.

Most systems will make use of thresholds configured in the following order of decreasing stack voltage.

Table 23. Stack Voltage Operational Limits

Register	Setting
stack_fault_voltage_over.thresh	The limit within the fault zone below which an explicit user operation is required to bring the system back into an operating state.
stack_fault_voltage_hi.thresh	The upper limit of the warning zone as per application requirements.
stack_warn_voltage_hi.thresh	The upper limit of the operating zone. Set just above stack_current_limit.voltage_stack_max.
stack_current_limit.voltage_stack_max	The voltage at which charge limits approach 0%. Set as per application requirements.
stack_current_limit.voltage_stack_high	The voltage at which charge current limits are reduced from 100%. Set as per application requirements.
stack_current_limit.voltage_stack_low	The voltage at which discharge current limits are reduced from 100%. Set as per application requirements.
stack_current_limit.voltage_stack_min	The voltage at which discharge limits approach 0%. Set as per application requirements.
stack_warn_voltage_lo.thresh	The lower limit of the operating zone. Set just below stack_current_limit.voltage_stack_min.
stack_fault_voltage_lo.thresh	The lower limit of the warning zone as per application requirements.
stack_fault_voltage_under.thresh	The limit within the fault zone below which an explicit user operation is required to bring the system back into an operating state.
stack_uvlo_stack_voltage.thresh	The under-voltage lockout threshold for system shutdown.



The under-voltage lockout feature can trigger the BMS to shut down when the stack voltage drops below this level. For more information on UVLO, refer to [Under-Voltage Lockout](#).

The stack voltage thresholds can be configured in a similar manner to how the cell voltage thresholds ([Section 4.6.2, “Cell Voltage Thresholds”](#)) are configured.

Concurrently, Nuvation Energy BMS includes separate voltage based triggers which derive from [Table 40, “Voltage and Temperature Sensor Specifications for all Configurations”](#).

Table 24. G5 Stack Switchgear Maximum Voltage Operational Limit

Register	Setting
ssg_fault_voltage_over.thresh	The absolute maximum rated voltage for the G5 Stack Switchgear.

User-defined triggers are also available for high and low stack voltages.

Table 25. User-Defined Stack Voltage Triggers

Register	Setting
stack_trig_voltage_hi.thresh	User-defined high stack voltage trigger.
stack_trig_voltage_lo.thresh	User-defined low stack voltage trigger.

Since stack voltage is measured independently from individual cell voltages in Nuvation Energy BMS, another important configuration threshold is the limit for mismatch between the overall stack voltage measurement and the sum of individual cell voltages.

`stack_fault_voltage_sum.thresh`

- The upper limit of the operating voltage mismatch zone
- Set as per application requirements (typically at least 5–10% of `stack_fault_voltage_over.thresh`)

4.6.6. External Controller Heartbeat

Nuvation Energy BMS can be configured to require a heartbeat signal from an external controller in order to keep the stack online and out of fault state. A write to the SunSpec controller heartbeat register is expected at least once during the watchdog period. If a multi-stack controller—such as the Nuvation Energy Multi-Stack Controller—is in use, it can periodically write to this register to keep the stack out of fault state.

`sc_controller_wdt.period`

- Trip time for watchdog if heartbeat disappears
- Set to 5 seconds or as per application requirements

`sc_fault_controller_wdt.disabled`

- Set to 0 to enable controller watchdog
- Set to 1 to disable controller watchdog

If this feature is not used, the watchdog fault should be disabled.

4.7. Control Settings

4.7.1. Current Control

Nuvation Energy BMS controls the current flowing through a battery stack:

1. During connection or disconnection of the battery to prevent harmful transient current events
2. During operation of a connected battery to keep the battery within its operational limits
3. During operation of a battery to keep the individual cells at a balanced state of charge
4. During a fault condition in order to protect the battery

Control for cases (1) and (4) is achieved through external switching devices that are under the control of Nuvation Energy BMS. This control is limited to hard switching. Control for case (2) is achieved through current limiting signals that are used by chargers and inverters to throttle current dynamically. Control for case (3) is implemented within Nuvation Energy BMS itself through passive balancing loads that are under control of a configurable balancing algorithm.

4.7.1.1. Stack Switch Functions

Nuvation Energy BMS defines three contactor switch functions for use within typical battery configurations:

- **Pre-charge Switch:** Connected during pre-charge operation only. Disconnected under fault condition.
- **Main Switch:** Connected after any pre-charge operation completes. Disconnected under fault condition.
- **Stack Switch:** Connected whenever either the pre-charge switch or the main switch is connected. Disconnected under fault condition.

While a *pre-charge contactor* is optional, virtually all systems require a *main contactor* to protect the battery from unsafe conditions.

A *stack contactor* is often used in conjunction with a main contactor, i.e. at the other end of the stack to isolate the battery stack completely from the DC bus and provide a level of contactor redundancy.

Stack connection and disconnection sequencing is illustrated in the state diagram below.

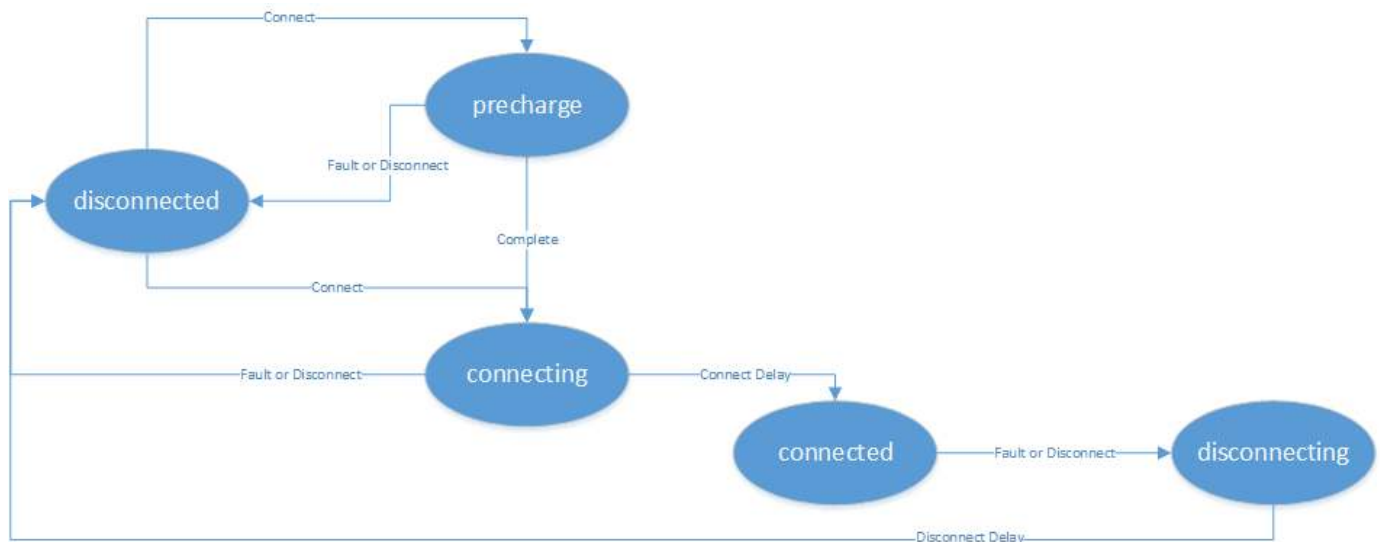

Figure 53. Battery Stack States and Transitions

As a system is connected and disconnected from the DC bus, a configurable sequencing delay is inserted before and after the connected state. During the connected state, the BMS uses current limits to control current flowing into and out of the stack. During all other states, current limits are set to zero. This allows for graceful switching behavior with no current flow under normal connect and disconnect requests.



The switch functions defined here must be mapped to appropriate outputs for use in an actual system. This process is covered in detail in [Section 4.8, “Input / Output Assignment”](#).

Auto-Connection Setting

It is sometimes desired for the Nuvation Energy BMS to automatically initiate a connection of a

battery stack when:

- The BMS powers on
- After all faults have been cleared

This operation can be configured with the following register setting.

`stack_control.auto_connect`

- When set to a value of one, the BMS will initiate a connection of the battery stack if there are no faults triggered
- When set to a value of zero, the BMS waits for a connection request from the Operator Interface or through one of its external interface. Note a stack will not connect if there is any faults triggered.

Pre-Charge Switch Settings

The pre-charge switch is engaged for a fixed (but configurable) amount of time during the pre-charge state.

If the pre-charge over-current fault is configured, the pre-charge will terminate if the fault is triggered. At the end of the pre-charge period, the following conditions are evaluated:

- At least one stack current sample was received
- The absolute value of the stack current is compared to be smaller than a maximum threshold value
- The absolute difference between the stack voltage and the DC Bus voltage is smaller than a maximum threshold

If all of the above conditions are true then the pre-charge operation was successful. Otherwise a pre-charge timeout fault is tripped. Upon successful pre-charge completion, the stack connection sequence continues. During the remaining connection sequence, both the main and pre-charge contactors are engaged. At the end of the connection sequence the pre-charge contactor is de-energized.

Pre-charge behavior is configured through the following registers as required for a particular application.

`stack_control.disable_precharge`

- If set to 1 then pre-charge is disabled
- If pre-charge is disabled the system will skip the pre-charge step and immediately enter the next part of the connection sequence

`stack_control.precharge_delay`

- Determines the fixed amount of time the pre-charge path is energized if enabled
- Set based upon pre-charge hardware power and thermal ratings
- This delay is limited to a minimum duration of 1 second and a maximum duration of 10 seconds



`stack_control.disable_precharge` must be set to 0 for this register to have an effect

`stack_control.disable_connecting`

- If value is set to 1, the system will immediately enter the connected state after pre-charge completes

`stack_control.connect_delay`

- Determines the minimum time both the pre-charge and main contactors are energized during connection
- This connection delay occurs after the pre-charge delay has successfully completed
- Set to a minimum of 1 second to ensure both contactors are energized at the end of the duration
- This delay is limited to a maximum duration of 10 seconds



`stack_control.disable_connecting` must be set to 0 for this register to have an effect

`stack_control.precharge_max_current`

- Determines the maximum current flow at the end of `stack_control.precharge_delay` under which pre-charge can complete successfully
- Set to ensure any in-rush currents upon main switch connection are within system ratings

`stack_control.precharge_connection_sequence`

- Determines which of the stack and pre-charge switches should be closed first during the pre-charge state
- In a multi-stack system, it is recommended to set the first stack to stack first and all subsequent stacks to pre-charge first
- Value of 0 closes stack switch first
- Value of 1 closes the pre-charge switch first

`stack_control.precharge_connection_sequence_override`

- Allows an external controller to override the `stack_control.precharge_connection_sequence` factory configuration value
- Value of 0 results in no override
- Value of 1 closes the stack switch first
- Value of 2 closes the pre-charge switch first

`stack_fault_precharge_over_current.thresh`

- Sets the over-current limit at any time during pre-charge
- If the fault is triggered, pre-charge will terminate immediately
- Limits the power dissipated of a pre-charge resistor during a short condition allowing for a smaller resistor

`stack_fault_precharge_timeout.disabled`

- Must be set to zero if pre-charge is enabled

A pre-charge operation only completes successfully if the stack current magnitude falls below the maximum pre-charge current within the configured delay time and the `stack_fault_precharge_over_current` does not trip.



If pre-charge is enabled the fault `stack_fault_precharge_timeout` must also be enabled.

Sequencing Delays

The following registers are used to configure the sequencing delays used before a stack enters the connected or disconnected state.

`stack_control.connect_delay`

- The delay between the contactors connecting and current limits engaging after a connect request
- This delay is important for systems using pre-charge
- When pre-charge is used the delay must be a minimum of one second and is limited to 10 seconds maximum



`stack_control.disable_connecting` must be set to 0 for this register to have an effect, otherwise the system will behave as if this delay is 0s

`stack_control.disconnect_delay`

- The delay between current limits disengaging and the contactors disconnecting after a disconnect request
- This delay is important to allow a PCS time to ramp down before the BMS opens the contactors
- This delay should not be less than one second and is limited to 10 seconds maximum



The [Section 4.11.4, "Fault Pilot"](#) is expected to be configured to allow stack connection to be maintained for `stack_control.disconnect_delay` period and have the PCS ramp power down before contactors. Please refer to this section for details when that fault pilot period is not maintained. This delayed response to disconnection will help in reducing the number of events that could degrade [Section 4.11.9, "Contactor Life Tracking"](#).

4.7.2. Contactor Configuration

Contactors that are used internally to the G5 Stack Switchgear must have a specific configuration to match its design and wiring.

The following registers are used to configure the internal contactors.

4.7.2.1. Contactor Configuration

Main Contactor

- `stack_contactor[0].installed = 1`

- `stack_contactor[0].inverted = 0`
- `stack_contactor[0].feedback_enable = 1`
- `stack_contactor[0].address_enable = 1`
- `stack_contactor[0].address = @stack_control[0].main_switch_state`

Pre-Charge Contactor

- `stack_contactor[1].installed = 1`
- `stack_contactor[1].inverted = 0`
- `stack_contactor[1].feedback_enable = 0`
- `stack_contactor[1].address_enable = 1`
- `stack_contactor[1].address = @stack_control[0].precharge_switch_state`

Stack Contactor

- `stack_contactor[2].installed = 1`
- `stack_contactor[2].inverted = 0`
- `stack_contactor[2].feedback_enable = 1`
- `stack_contactor[2].address_enable = 1`
- `stack_contactor[2].address = @stack_control[0].stack_switch_state`



The registers `stack_contactor[0:2].delay` and `stack_contactor[0:2].direction` are not used and their configuration can be ignored.

4.7.3. Current Limits

The Nuvation Energy BMS supplies configurable current limits for the charge and discharge directions of a battery stack. The current limits provide a feedback to an external control system to gradually taper the current demanded from the battery as the stack approaches its full (100% SOC) and empty (0% SOC) states.

The current limits are calculated by taking the minimum of the following input variables:

1. Cell Voltage (refer to [Figure 47, "Typical Arrangement of Cell Voltage Current Limits"](#))
2. Cell Temperature (refer to [Figure 49, "Typical Arrangement of Temperature Current Limits"](#))
3. Stack Voltage (refer to [Figure 52, "Typical Arrangement of Stack Voltage Current Limits"](#))

The charge/discharge current limits can be accessed via the following outputs:

BMS Registers

`stack_current_limit.charge_current_limit`

- The charge current limit in milliamps.

stack_current_limit.discharge_current_limit

- The discharge current limit in milliamps.

SunSpec (Draft 3) Modbus Points

SunSpec 802 Model: Maximum Charge Current (MaxBatACha)

- Modbus address 40106 at unit identifier 1
- Single point of unsigned data
- Units of Amperes once scaled

SunSpec 802 Model: Maximum Discharge Current (MaxBatADischa)

- Modbus address 40107 at unit identifier 1
- Single point of unsigned data
- Units of Amperes once scaled



A scaling factor has to be applied to the current limits read from the SunSpec 802 model. The scaling factor can be read from Modbus address 404014. The scaling factor is an exponent of a base 10 adjust applied to the data read. (e.g. a scaling factor of -3 means the current limits are divided by 1000). The scaling factor is constant for the Battery Management System operation.

4.7.3.1. Current Limit Behavior

The calculated current limits are only updated to the [outputs](#) only when the Nuvation Energy BMS is in the [connected state](#). Outside of this state, the current limits are set to zero to indicate that the external power controller should not be charging or discharging the battery stack. This behavior is most important during the [Disconnecting](#) state. When the current limits do go to zero, there will be a time granted to the external controller to ramp down power before the contactors are opened. Such behaviour allows the [contactor life](#) to be protected and avoid opening Battery Management System contactors at elevated currents.

4.7.3.2. Current Limit Configuration

The configuration for the limits of the current limits for each contributing measurement was provided in earlier sections:

- Cell Voltage (refer to [Table 14, "Cell Voltage Operational Limits"](#))
- Cell Temperature (refer to both [Table 16, "Charge Temperature Operational Limits"](#) and [Table 17, "Discharge Temperature Operational Limits"](#))
- Stack Voltage (refer to [Table 23, "Stack Voltage Operational Limits"](#))

The following sections detail additional configuration of current limits.

Maximum Operating Currents

The maximum continuous operating charge and discharge currents must be configured for current

limiting to function properly. These values correspond to the current limit values that will be used during normal wide-open operation (i.e. no throttling).

`stack_current_limit.max_charge_current`

- Magnitude of maximum continuous operating charge current

`stack_current_limit.max_discharge_current`

- Magnitude of maximum continuous operating discharge current



The current limits given above are magnitudes only—i.e. both charge and discharge current limits are positive.

Minimum Charge Current

The minimum charge current is the constant charging current that should be applied as the battery reaches the end of its charge cycle. The BMS will ensure that the charge current limit does not fall below this minimum value until the battery has reached its maximum charging voltage.

`stack_current_limit.min_charge_current`

- Minimum charge current to be applied at the end of charge cycle
- Set as per battery manufacturer recommendations (typically below C/20)

This setting must be configured in conjunction with the full thresholds defined by [Stack Capacity](#). For example, the stack can be considered full once the current limit reaches the minimum charge current.



The current limit given above is magnitude only—i.e. charge current limit is positive.

Current Limiting Response Times

The current limiting control loop can be tuned for stable and responsive behavior in a variety of systems. Two independent settling times are provided to allow independent adjustment of the response to decreases in current limits (attack time) and increases in current limits (decay time).

`stack_current_limit.attack_settling_time`

- Settling time for decreases in current limits
- Typically this is between 1 and 5 seconds

`stack_current_limit.decay_settling_time`

- Settling time for increases in current limits
- Typically this is on the order of 10x larger than `stack_current_limit.attack_settling_time`

`stack_current_limit.nonlinear_rolloff`

- Enables a non-linear roll-off of the current limits when set to True (i.e. a value of one)
- Current limits will follow a linear response when set to False (i.e. a value of zero)

Since the attack time determines how quickly the current limits can respond before a potential fault conditions opens a switch, it is critical to have sufficient control bandwidth here to avoid tripping

faults.

A non-zero settling time is critical in most applications to avoid oscillations in the presence of noise and other imperfections in high-power control of the DC current in the charger and/or inverter.

When the nonlinear roll-off is enabled, the slope of the current limits at the end of the charge/discharge regions will be smaller (closer to zero) than the linear response. A nonlinear roll-off will reduce large changes in variables (such as the cell voltage) on the current limit output.

4.7.4. Passive Cell Balancing

When multiple cells are connected in series to form a larger battery stack, it is important to ensure each cell is giving equal contributions to the system. The effects of a single low State-of-Charge or a single high State-of-Charge cell will dominate the performance of the large battery stack. The act of equalizing State-of-Charge of multiple series-connected cells is called *balancing* and there are many types of balancing.

Nuvation Energy BMS implements a *passive* balancing solution. Cells with high State-of-Charge are discharged via internal bleed resistors which are enabled on a per-cell basis. Properly adjusting the algorithm settings for your cells is necessary to achieve a well-performing system.

A number of configurable settings are used to fine-tune the passive balancing algorithm for voltage, temperature, current, and duty cycle.

There are two choices of balancing algorithms available to execute on the Nuvation Energy BMS. Only one of the algorithms can be enabled at a time. Enabling one algorithm will immediately disable the other algorithm.

`stack_balancing_selector.enable_voltage_balancer`

- Set to 1 to enable.
- Balancing that is based only the differences between cell voltages.

This balancing approach can only occur when there are differences between cell voltages. For popular battery chemistries liker LFP, the regions where cell voltage differences are large enough are only available at the very top and bottom of the [Section 4.4.5, "Open Circuit Voltage Curve"](#). A battery stack must remain in these regions of low and high SOC until balancing has completed. This balancing process can take many hours to complete and prevents the stack from being charged/discharged.

`stack_balancing_selector.enable_soc_balancer`

- Set to 1 to enable
- Balancing that is based only the differences in SOC imbalances between cells.

Similarly to voltage based balancing, the estimates for cell imbalance are largest at the regions where the cell voltages change rapidly. However after these imbalance estimates are measured, the battery stack can return to operation while the measured cell imbalances are continuously removed.

4.7.4.1. Voltage Based Cell Balancing

Settings for Voltage Based Cell Balancing

Both absolute and relative cell voltage thresholds are used to safely balance a stack of batteries.

min_enable_voltage is the absolute threshold that determines the voltage below which a cell will not be balanced. This prevents over discharging in a system even with large imbalances.

voltage_delta is the relative threshold that is used to determine when a system is balanced. Balancing for a given cell will take place when that cell's voltage is at least `voltage_delta` millivolts higher than the minimum cell voltage.

`stack_cell_voltage_balancer.min_enable_voltage`

- Minimum voltage threshold for balancing (mV). The minimum cell voltage threshold for balancing must be greater than, or equal to, 1.1 V.
- Typically this is set higher than `stack_current_limit.voltage_cell_high`

`stack_cell_voltage_balancer.voltage_delta`

- Delta voltage threshold for balancing (mV)
- Delta between a given cell's voltage and the minimum cell voltage
- Typically this is set between 5 and 25 mV



If `stack_cell_voltage_balancer.voltage_delta` is set to zero, the system will continue balancing down all cells (even if the difference between min and max is zero) until they reach `stack_cell_voltage_balancer.min_enable_voltage`. This mode can be used to passively balance all cells in a stack to a specific open-circuit voltage.

Cell Balancing Temperature Settings

Temperature limits are used to prevent the cells and the BMS module from overheating. If the following temperature threshold is exceeded, balancing is disabled for all cells in the stack.

`stack_cell_voltage_balancer.max_enable_temperature`

- The upper cell temperature limit, in degrees °C, as measured by thermistors external to the BMS
- Set per application requirements.

Cell Balancing Current Settings

Thresholds based on stack current allow the balancer to be fine-tuned to run during specific portions of the charge and discharge cycle.

`stack_cell_voltage_balancer.min_enable_current`

- The minimum current at which balancing remains enabled (mA)
- This is typically set to a negative value to enable balancing below certain charge currents

- For example, a value of -10000 causes balancing to be **disabled** when charging at greater than 10 A

`stack_cell_voltage_balancer.max_enable_current`

- The maximum current at which balancing remains enabled (mA)
- This may be a negative or positive value depending upon application requirements
- For example, a value of 200 causes balancing to be **disabled** when discharging at greater than 200 mA

The two most common use cases are:

1. **Balance only while charging:** In this case, both the minimum and maximum current thresholds are set to negative values that correspond to the range of charge currents under which balancing should take place.
2. **Balance while charging and holding:** In this case, the maximum current threshold is set to a slightly positive value so that the stack will balance when it is idle or disconnected. The level of discharge current flow tolerated during idle balancing is application-specific and is thus configurable.

4.7.4.2. Cell Balancing Duty Cycle

All the energy that is removed from a cell by passive balancing is dissipated as heat. If the amount of heat dissipated is too great, its desirable to reduce the amount of balancing applied to the cells. Passive balancing is applied for the majority of a cell voltage scan period defined by the register `sc_linkbus[0].scan_period`. Balancing is disabled every linkbus scan cycle to measure the cell voltages. The register `sc_linkbus[0].balance_settle_period` provides the period of time balancing is turned off before measuring cell voltages. The duration of balancing applied to all cells can be reduced by increasing this delay period.



The `sc_linkbus[0].balance_settle_period` register value must be between a minimum of 50 ms and must be smaller than the linkbus scan period.

4.7.5. Continuous Balancing

G5 High-Voltage BMS introduces a passive balancing algorithm which increases the operational time of a battery stack and minimize the time spent balancing cells. Traditional voltage based balancing requires that the cells maintain a difference in voltages to identify the cells requiring balancing. This voltage difference must be maintained to allow balancing to act on the cells of the highest voltages. Such an operation can cause the battery stack to be offline for hours to allow the cell balancing to complete. Furthermore, the regions of SOC which have a large range of cell voltage are limited with popular battery chemistries such as LFP. Refer to [Figure 54, "Limited Regions for Cell Balancing for LFP Cells."](#) which shows for a typical LFP chemistry, the best regions for balancing are at less than 10% and greater than 99% state of charge.

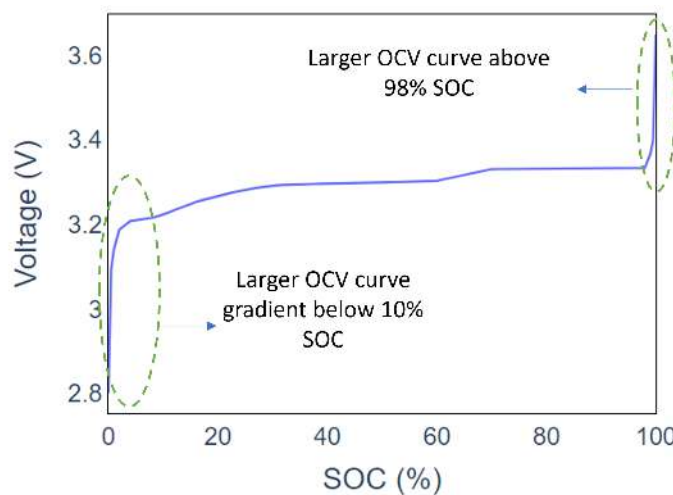

Figure 54. Limited Regions for Cell Balancing for LFP Cells.

Continuous balancing is an algorithm that minimizes this operational downtime by the following procedure:

1. A Nuvation Energy BMS continuously provide estimates on the imbalance in cells of a stack. The best results of imbalance estimations are often at the top of a charge cycle of a battery stack.
2. When balancing is desired to be executed on a stack, the stack needs to be charged up to near its full state (> 99% SOC) or near its empty state (< 10% SOC).
3. After the imbalance estimates have been established, the software will begin to apply passive balancing to the cells with the highest imbalance. A stack can resume its operation while this balancing occurs.
4. BMS software provide status on the amount of imbalance remaining for the cells. After the imbalance has been removed, it is suggested that the stack could repeat its charge cycle to capture the next cell imbalance estimates.
5. This process is repeated until the imbalance estimates are small and no longer trigger any balancing actions.



Cell imbalance estimations are periodically persisted and will recover after a reboot of the G5 Stack Switchgear



Cell balance estimations uses confidence intervals and are only updated when there is a high confidence in the imbalance estimation. The best confidence estimates for imbalance are at the top of the charge cycle in the final few SoC percentages before a stack is full. It is highly suggested that the stack is controlled using a properly configured BMS current limits to approach the full state of a stack. Refer to [Section 4.7.3, "Current Limits"](#) for further details.

4.7.5.1. Frequency of Continuous Balancing

As a general recommendation, it is suggested that continuous balancing is performed every 2 weeks on a maintenance cycle for a typical LFP battery chemistry. This recommendation may vary

depending on the application and cell chemistry of the battery stack. Nuvation Energy has prepared an application note on the frequency of this maintenance cycle which can be applied to a customers application. Please contact support@nuvationenergy.com to receive this application note.

4.7.5.2. Cell Imbalance Estimation Components

The following are the components associated with cell imbalance estimation.

Table 26. Cell Imbalance Components

Component	Instances	Description
stack_soc_distribution_estimator	480	Component that estimates the soc distribution at a per cell level using voltage measurements.
stack_imbalance_estimator	1	Component that estimate cell level imbalance using the soc distribution values
cell_imbalance	480	Component that stores the value of the imbalance estimates at a per cell level

4.7.5.3. Cell Imbalance Estimations Configuration

Cell imbalance estimation is configured using the following registers:

Table 27. Cell Imbalance Estimation Configuration

Register	Suggested Value	Description
stack_soc_distribution_estimator[0]. enabled	1	Enables the estimation of SoC distribution used in the new balancing algorithm.
stack_soc_distribution_estimator[0]. measurement_error	3	Standard deviation of the noise in the voltage measurements.
stack_soc_distribution_estimator[0]. ohmic_resistance_error	Nominal_resistance * 0.05	Standard deviation of the noise in the ohmic resistance estimates.
stack_soc_distribution_estimator[0]. ohmic_resistance_error	Nominal_resistance * 0.05	Standard deviation of the noise in the ohmic resistance estimates.
stack_soc_distribution_estimator[0]. critical_value	2	Value used to determine the upper and lower thresholds of confidence interval. For a normal distribution, a value of 2 indicates 95% confidence.
stack_imbalance_estimator[0]. upper_estimation_soc_window	98	Defines an SoC estimation window, from full to a specific SoC point, where imbalance estimation can occur. A value of 95% means, imbalance estimation can occur between 95% and 100% SoC. Set this value to 100% when doing bottom-balancing.
stack_imbalance_estimator[0]. lower_estimation_soc_window	0	Defines an SoC estimation window, from a specific SoC point to empty, where imbalance estimation can occur. A value of 5% means, imbalance estimation can occur between 0% and 5% SoC. Set this value to 0% when doing top-balancing.

Register	Suggested Value	Description
stack_imbalance_estimator[0].upper_estimation_voltage_window	stack_soc.vfull - 15	Defines a voltage estimation window, from full to a specific voltage point, where imbalance estimation can occur. A value of 3580 mV means, imbalance estimation can occur above 3580 mV. Set this value to stack_soc.vfull - 15 when doing top-balancing.
stack_imbalance_estimator[0].lower_estimation_voltage_window	stack_soc.vempty + 15	Defines a voltage estimation window, from a specific voltage point to empty, where imbalance estimation can occur. A value of 2850 mV means, imbalance estimation can occur below 2850 mV. Set this value to stack_soc.vempty + 15 when doing bottom-balancing.
stack_imbalance_estimator[0].estimation_current_window	stack_soc.ifull + 1000	In addition to constraining imbalance estimation using voltage measurements, the measured current can be used to restrict when an imbalance estimate is generated. A value of 8000 mA means that imbalance estimation will only occur if the absolute value of the measured current is below this value.
stack_cell_state_estimator[0].disable_measurement_update	1	Register to disable the measurement update for estimating the battery states.



Cell imbalance estimation requires the configuration of an OCV table for the cells. Enabling imbalance detection is not meaningful without this configuration.

4.7.5.4. Cell Imbalance Estimations Status

The following registers provide a status of the imbalance estimates. The imbalance estimates are reduced by the amount of energy removed from applied balancing. Balancing will halt when all imbalance estimates are reduced to zero.

Table 28. Cell Imbalance Registers

Registers	Instances	Description
stack_imbalance_estimator[0].imbalance_estimation_uncertainty	1	Register used to qualify the uncertainty associated with the imbalance estimation.
cell_imbalance[0].imbalance_estimate	480	Register to store the amount of estimated cell imbalance as output from the stack_imbalance_estimator

4.7.5.5. Continuous Balancing Configuration

Two new configuration registers have been added for configuring the continuous balancing algorithm

Table 29. Continuous Balancing Algorithm Configuration

Register	Suggested Value	Description
stack_balancing_selector[0].enable_soc_balancer	1	Enables the execution of the continuous balancing algorithm, that is based on cell level SoC.
stack_imbalance_estimator[0].balancing_resistor	26000000	Value of the resistor in the Nuvation Energy G5 Cell Interface used for balancing.



In addition to these configurations, the continuous balancing algorithm requires the configuration of the open cell voltage curve. Refer to [Section 4.4.5, “Open Circuit Voltage Curve”](#) for further details.

4.7.5.6. Balancing Counters per Cell

There is a persistent counter per cell of its number of cell balancing events. Every time during a cell measurement scan, any cell that is requested to be balanced has its corresponding counter incremented by one.

`cell[instance].balancing_event_count`

Refer to [CI24 configuration](#) to determine the instance for a given CI and cell channel.

As long as the period of the CI scan does not change of over the life time of the stack operation, the total amount of balancing time can be calculated as follows:

Total balancing time [s] = `cell[instance].balancing_event_count * sc_linkbus.scan_period / 1000000`

The balancing event counters are persisted to non-volatile storage on a hourly period.

4.7.5.7. Thermal Throttling for Cell Balancing

The G5 High-Voltage BMS now provides the capability to throttle cell balancing based on the internal temperature of G5 Cell Interface. Since the continuous balancing algorithm can balance for the full range of battery operation, throttling of balancing is done to protect the G5 Cell Interface from over-heating. There are two internal temperatures read from each G5 Cell Interface. These measurements are available from the following registers:

- `ci[0:19].ci_temperature_1`
- `ci[0:19].ci_temperature_2`

If the maximum temperature on any Nuvation Energy G5 Cell Interface exceeds a configurable threshold, balancing is turned off for all the cells on that over-temperature G5 Cell Interface. Balancing is then re-enabled if the maximum G5 Cell Interface temperature falls below a second configurable threshold.



The thermal throttling for balancing is independent of the type of balancing algorithm selected.

Configuration

Thermal throttling introduces two configuration registers for when to disable and re-enable cell balancing.

Table 30. Thermal Throttling Configuration

Register	Suggested Value	Description
stack_balancing_throttling_estimator[0].disable_balancing_temperature	80	Maximum temperature threshold of the Nuvation Energy G5 Cell Interface, above which balancing is disabled.
stack_balancing_throttling_estimator[0].enable_balancing_temperature	70	Once the balancing has been disabled due to high temperature, this second threshold represents the temperature of the Nuvation Energy G5 Cell Interface below which balancing can be re-enabled.



The second re-enable threshold can be disabled by setting the enable_balancing_temperature to be the same value as the disable_balancing_temperature.

4.7.6. Fan Control (AC/DC)

The G5 Stack Switchgear provides two options to control external AC or DC fans:

1. Fans are turned on/off based on the current maximum cell temperature.
2. Fans are turned on/off by manual control

Refer to [Connect Power In and Fan Control](#) for instructions on wiring and installation of fans to the G5 Stack Switchgear.



If the fans are on at the start of a contactor closing sequence, they will be turned off and back on at the end of the sequence. This is an expected response of the fan control.



The DC fan warning will trigger when no fans are installed. Please disable the warning if no fans are installed.

4.7.6.1. Temperature Based Fan Control

The temperature based fan control introduces new triggers that are configured to control the fan output. These registers allow for temperature control in both the charge/discharge directions of the stack. These triggers are as follows:

1. ssg_trig_fan_control_charge
2. ssg_trig_fan_control_discharge

These charge/discharge triggers are aggregated to a single component named `ssg_trig_fan_control_aggregate`. These trigger components are based on standard hysteresis trigger components used in the BMS. Refer to [Section 4.6.1.3, "Hysteresis Triggers"](#) for general guidance on how to configure them. It's recommended that the latched configuration of these registers be set to zero to allow the fans to automatically turn off as the temperatures of the cells drop below their configured limits.

There are separate controls to enable output for either or both AC or DC fan outputs. The configuration for this fan control is managed by the following registers.

Table 31. Fan Control Configuration

Register	Recommended Values	Description
<code>ssg_fan_control_ac[0].address</code>	<code>@ssg_trig_fan_control_aggregate[0].trig</code>	Register to define the address of the register whose value is used for AC fan control output.
<code>ssg_fan_control_ac[0].address_enabled</code>	1	Register used to enable the temperature control of the AC fans using the register address defined previously.
<code>ssg_fan_control_dc[0].address</code>	<code>@ssg_trig_fan_control_aggregate[0].trig</code>	Register to define the address of the register whose value is used for DC fan control output.
<code>ssg_fan_control_dc[0].address_enabled</code>	1	Register used to enable the temperature control of the AC fans using the register address defined previously.

4.7.6.2. Manual Fan Control

The manual fan control allows external management to turn on and off fans of the Nuvation Energy BMS. It also could be used to verify that the wiring of fans is correct after installation. This control is managed by writing a value of zero or one to the following registers. Writing a value of one to these registers will turn on the fans. Writing a value of zero to these registers will turn off the fans.

1. `ssg_fan_control_ac.requested_state`
2. `ssg_fan_control_dc.requested_state`



Refer to [Section 5.4.1.5, "Configurable Modbus"](#) for details on how to use the Configurable Modbus feature to both read and write to these control registers external from the Battery Management System.

To enable manual control of the fans, the following configuration must be completed. This configuration will disable any internal management of the fan control by the Battery Management System firmware.

Table 32. Fan Control Configuration

Register	Recommended Values
<code>ssg_fan_control_ac[0].address</code>	0
<code>ssg_fan_control_ac[0].address_enabled</code>	0

Register	Recommended Values
ssg_fan_control_dc[0]. address	0
ssg_fan_control_dc[0]. address_enabled	0

4.7.6.3. DC Fan Warning

An independent warning for DC fan power failures is provided. The component `ssg_warn_fan_control_dc_error` provides information on failures of the DC fan operation as detected by the hardware driver. This warning uses a hysteresis trigger. The default settings of this trigger are the expected configuration for this warning.

Table 33. Default Settings for a DC Fan Warning

Register	Description
ssg_warn_fan_control_dc_error[0].disabled	1
ssg_warn_fan_control_dc_error[0].thresh	1
ssg_warn_fan_control_dc_error[0].time_hyst	0
ssg_warn_fan_control_dc_error[0].end_time_hyst	2000000
ssg_warn_fan_control_dc_error[0].latched	0



The DC fan warning will trigger when no DC fans are installed. The warning default configuration is disabled because of this behavior.



There is no equivalent warning for an AC fan.

4.8. Input / Output Assignment

The G5 Stack Switchgear implements the following inputs and outputs:

- [Section 4.8.1, "General Purpose Digital Outputs"](#)
- [Section 4.8.2, "General Purpose Digital Inputs"](#)
- [Section 4.8.3, "Disconnect Input"](#)
- [Section 4.8.4, "UVLO Enable Config Switch Input"](#)
- [Section 4.8.5, "Network Reset and Factory Restore Config Switch Inputs"](#)
- [Section 4.8.6, "Shutdown Input"](#)
- [Section 4.8.7, "Enable Input"](#)

4.8.1. General Purpose Digital Outputs

G5 Stack Switchgear provides 2 General Purpose Digital Outputs. The most commonly used *General Purpose Digital Output* functions are:

- **Charge current disable:** A control signal that is asserted when charging should be disabled

- **Discharge current disable:** A control signal that is asserted when discharging should be disabled
- **Fault state:** A signal that is asserted when faults are present within the system
- **Trigger state:** A trigger signal for external devices that is asserted when a specific trigger within the system is tripped

General Purpose Digital Output functions are assigned through the following configuration registers. The index **n** is the zero-based index of the *General Purpose Digital Output* hardware pin.

`sc_gpo[n].address_enabled`

- Set this to 1 to enable the function specified in `sc_gpo[n].address`

`sc_gpo[n].inverted`

- When set to 0, GPO output switch is **closed** when assigned function value is 0
- When set to 1, GPO output switch is **closed** when assigned function value is 1

`sc_gpo[n].address`

- Determines the function mapped to output

The configuration settings for the most common functions are illustrated in the table below.

Table 34. Common Assignments for General Purpose Digital Output

Function	<code>sc_gpo[n].address</code>	<code>sc_gpo[n].inverted</code>
Charge Current Enable	@stack_current_limit.charge_current_disable	0
Discharge Current Enable	@stack_current_limit.discharge_current_disable	0
Fault State	@stack_trigger_summary.fault	1
Trigger State	@trigger_name.trig	1

For advanced applications, *General Purpose Digital Outputs* may be configured to be driven from any Boolean register within the BMS.

4.8.2. General Purpose Digital Inputs

G5 Stack Switchgear provides 2 General Purpose Digital Inputs. The most commonly used *General Purpose Digital Input* functions are:

- **Clear faults:** Hardware input to clear any latched fault conditions
- **Fault Input:** Request to fault to be generated by the Nuvation Energy BMS due to an external event (such as ground fault detection)

General Purpose Digital Input functions are assigned through the following configuration registers. The index **n** is the zero-based index of the *General Purpose Digital Input* hardware pin.

`sc_gpi[n].address_enabled`

- When set to 1, the state of the input pin is propagated to the destination register address

`sc_gpi[n].inverted`

- When set to 0, GPI input value is 1 if hardware GPI is asserted
- When set to 1, GPI input value is 0 if hardware GPI is asserted

`sc_gpi[n].address`

- The destination register address to populate with the state of the input pin

`sc_gpi[n].rising_edge_triggered`

- When set to 1, the input value will be populated to the destination upon detection of a rising edge

`sc_gpi[n].falling_edge_triggered`

- When set to 1, the input value will be populated to the destination upon detection of a falling edge

If the *General Purpose Digital Input* is configured as neither rising nor falling edge triggered, the input value is continuously populated into the destination address. The configuration settings for the most common functions are illustrated in the table below.

Table 35. Common Assignments for General Purpose Digital Input

Function	<code>sc_gpi[n].address</code>	<code>sc_gpi[n].inverted</code>	<code>sc_gpi[n].rising_edge_triggered</code>
Clear Faults	<code>@stack_trigger_summary.clear_faults</code>	0	1
Connect Request	<code>@stack_control.requested_state</code>	0	1

For advanced applications, *General Purpose Digital Input* may be configured to drive any Boolean register within the BMS.

4.8.3. Disconnect Input

A separate Disconnect input is available on the G5 High-Voltage BMS as noted in [I/O Connector](#). When the Disconnect input is asserted it will instruct the hardware/software to disconnect the stack. There are two modes of operation of the Disconnect input:

1. Nominal: Issues a software controlled disconnect sequence
2. Quick: Issues an immediate hardware controlled disconnect



For either mode, the BMS software requires a minimum assertion of 500 ms to make sure the Disconnect request is captured.



See [Section 8.4, “Disconnect Input Causing Faults to Trip”](#) for configuration details to avoid tripping faults when using the Disconnect Input.



The state of the Disconnect input may be read via the register `ssg_hw_disconnect.disconnect_state`



Review all the restrictions of this input behavior as noted in [I/O Connector](#)

4.8.3.1. Configuration

Table 36. Disconnect Input Configuration

Register	Description
ssg_hw_disconnect[0].mode	Configured with a value of either 0 = Nominal (software controlled) or 1 = Quick (hardware controlled)
ssg_hw_disconnect[0].inverted	Inverts the active state of the disconnect signal to the hardware. When inverted = 0, the Disconnect input is an active low signal while when inverted = 1, the Disconnect input is an active high signal.

4.8.3.2. Quick Disconnect

A quick disconnect provides the capability to configure the G5 Stack Switchgear to immediately disconnect a stack when its Disconnect input is asserted. Shortly after the assertion of the Disconnect input, the G5 Stack Switchgear hardware will remove power simultaneously from all contactors. The minimum assertion period must be maintained on this signal while in this mode.

4.8.4. UVLO Enable Config Switch Input

The enabling/disabling of the UVLO feature is managed by a config switch setting. UVLO is enabled on the G5 High-Voltage BMS when the config switch is placed in the ON position. Refer to [Section 3.3.3.9, "Set the Config Switches"](#) for details on the config switches.



The state of the UVLO Enable input may be read via the register `ssg_uvlo_enable.value`



The configuration of the UVLO feature is detailed in [Section 4.11.5, "Under-Voltage Lockout"](#)

4.8.5. Network Reset and Factory Restore Config Switch Inputs

The G5 Stack Switchgear supports network reset and factory restore features that can restore the BMS to one of its two factory states:

1. The network IP configuration is reset to its factory configuration. The current firmware and its configuration are not changed.
2. The network IP, factory image, and configuration are restored.



Network Reset and Factory Restore are not required during installation of a new G5 Stack Switchgear.

The selection of either restore function is achieved through the use of the config switches on the front face panel along the right-side of the G5 Stack Switchgear. Refer to [Section 3.3.3.9, "Set the Config](#)

[Switches](#)” for details on these config switches. The process of issuing a network reset or factory restore using the config switches is as follows:

1. Remove power from the G5 Stack Switchgear.
2. Locate the network reset and factory restore config switches on the front face along the right-side of the G5 Stack Switchgear. The bottom two DIP switches are labeled *Network Reset* and *Factory Restore*. Select the switch labeled *Network Reset* to reset only the network configuration. Select the switch *Factory Restore* to restore factory firmware and configuration, including network configuration.
3. Set either switch to the ON position prior to applying power.

Factory Restore	Network Reset	Restore State
OFF	ON	Reset network configuration
ON	Either ON or OFF	Reset network configuration, restore factory firmware & configuration

4. Reapply power to the G5 Stack Switchgear.
5. The G5 Stack Switchgear LED’s provide a visual indication as to which restore option is requested, see [Table 49, “G5 High-Voltage BMS State based on LED Status”](#).
6. To start the network reset or factory restore, acknowledge the restore config selection by setting the *Network Reset* and *Factory Restore* switches to the OFF position. This starts the network reset or factory restore process.
7. The LED pattern continues until the restore operation has completed.



If this user action is not completed in 30 seconds after the boot of the G5 Stack Switchgear, the restore is aborted and a nominal boot of the G5 Stack Switchgear is initiated. The G5 Stack Switchgear can have its power removed and reapplied to re-initiate the restore mode with the same config switch settings.

8. When factory restore has completed, the G5 Stack Switchgear will reboot.
9. G5 Stack Switchgear boots and is now accessible over its factory configured IP. The green power LED is ON.



The Factory IP setting can be read from a front panel label on the G5 Stack Switchgear



Power should remain uninterrupted during the factory restore procedure. A power failure during a factory restore could leave G5 Stack Switchgear in an inoperable state.

4.8.5.1. Network Reset Switch

The state of the Network Reset switch may be read via the register `ssg_factory_restore_1.value`

4.8.5.2. Factory Restore Config Switch

The state of the Factory Restore switch may be read via the register `ssg_factory_restore_0.value`

4.8.6. Shutdown Input

The G5 Stack Switchgear provides a Shutdown input to allow for external shutdown. When the shutdown input is asserted for a minimum of 0.5 seconds, firmware will begin the process of disconnecting stacks (if connected) and then remove power from the G5 Stack Switchgear. The Shutdown input could remain asserted for longer durations. If the Shutdown is asserted continuously for 10 seconds, the G5 Stack Switchgear hardware will power down.



The Enable input ([Section 4.8.7, “Enable Input”](#)) can be asserted to reapply power to the G5 Stack Switchgear while in its power down state.



While the G5 High-Voltage BMS remains powered, the state of the Shutdown input may be read via the register `ssg_shutdown.value`.



Shutdown will not be able to remove power if the UVLO feature is disabled in hardware. Refer to [Table 8, “Config Switch Settings”](#) for details on how to configure hardware to enable/disable UVLO. The firmware configuration for UVLO has no impact for Shutdown feature. There is no firmware configuration required for the Shutdown feature.

4.8.7. Enable Input

The Enable input can be asserted to the G5 Stack Switchgear to do the following:

- apply power to the G5 Stack Switchgear while in its power down state,
- override the Shutdown input ([Section 4.8.6, “Shutdown Input”](#)), or
- keep power on during a UVLO event ([Section 4.8.4, “UVLO Enable Config Switch Input”](#)).

The Enable input keeps the G5 High-Voltage BMS turned on when features like Shutdown or UVLO are turning off the G5 High-Voltage BMS. Assert the Enable input to prevent these prior actions from happening. For example if a stack has a critically low cell and UVLO is triggered, use the Enable input to power on the G5 High-Voltage BMS to enable charging the stack.

Refer to [Section 4.11.5, “Under-Voltage Lockout”](#) for details on UVLO, Shutdown and Enable features. Refer to [Enable Input](#) diagram for further details on the hardware specifications of this input.

The state of the Enable input may be read from the register `ssg_enable.value`.

4.9. External Communication Interface Settings

The G5 Stack Switchgear supports a 10/100 Ethernet interface for Modbus TCP and Operator Interface connectivity with external systems. Refer to [Section 5.4.1, “Modbus Protocol Support”](#) and

[Section 5.3, "Using the Operator Interface"](#) for details on the protocols and services offered.

4.10. Measurement Calibration

The Nuvation Energy BMS provides calibration settings which allow the system to be fine-tuned for integration with a variety of measurement sensors. The preset values that ship with the BMS can be adjusted as required.

4.10.1. Thermistor Calibration

Nuvation Energy BMS can be configured to use any thermistor. A function that converts measured voltage into temperature must be determined and configured for the particular thermistor in use.

A sixth-order polynomial is used within the BMS to model this transfer function:

$$T(v) = C_0 + C_1 \cdot v + C_2 \cdot v^2 + C_3 \cdot v^3 + C_4 \cdot v^4 + C_5 \cdot v^5 + C_6 \cdot v^6$$

`stack_therm_poly.coeff0` (Factory)

- Set to C_0 (Floating-point value)

`stack_therm_poly.coeff1` (Factory)

- Set to C_1 (Floating-point value)

`stack_therm_poly.coeff2` (Factory)

- Set to C_2 (Floating-point value)

`stack_therm_poly.coeff3` (Factory)

- Set to C_3 (Floating-point value)

`stack_therm_poly.coeff4` (Factory)

- Set to C_4 (Floating-point value)

`stack_therm_poly.coeff5` (Factory)

- Set to C_5 (Floating-point value)

`stack_therm_poly.coeff6` (Factory)

- Set to C_6 (Floating-point value)

The thermistor voltage is read by a 10 kΩ pull-up to 3.00 V DC. The first step in calculating coefficients for a thermistor is to create a table in Microsoft Excel™ or equivalent spreadsheet application with the following columns:

Temperature (°C)	Resistance (Ω)	Vadc (V)
-40	334274	2.91286
-35	241323	2.88063
.....
125	336.75	0.09773

Temperature and resistance values are taken from the datasheet of the thermistor. V_{adc} is calculated using the following formula:

$$V_{adc} = 3.0 \left(\frac{R}{R + 10000} \right)$$

Using the line plot feature, create a graph of V_{adc} vs Temperature and turn on the trend line. Then modify the trend line to be a 6th order polynomial type, and display the equation on the chart. The equation will look like:

$$T(V) = (151.68) + (-352.94)V + (549.33)V^2 + (-482.08)V^3 + (223.69)V^4 + (-51.518)V^5 + (4.5693)V^6$$

These polynomial coefficients can then be used to configure Nuvation Energy BMS for this thermistor. An example plot of these measurements is shown in the next figure.

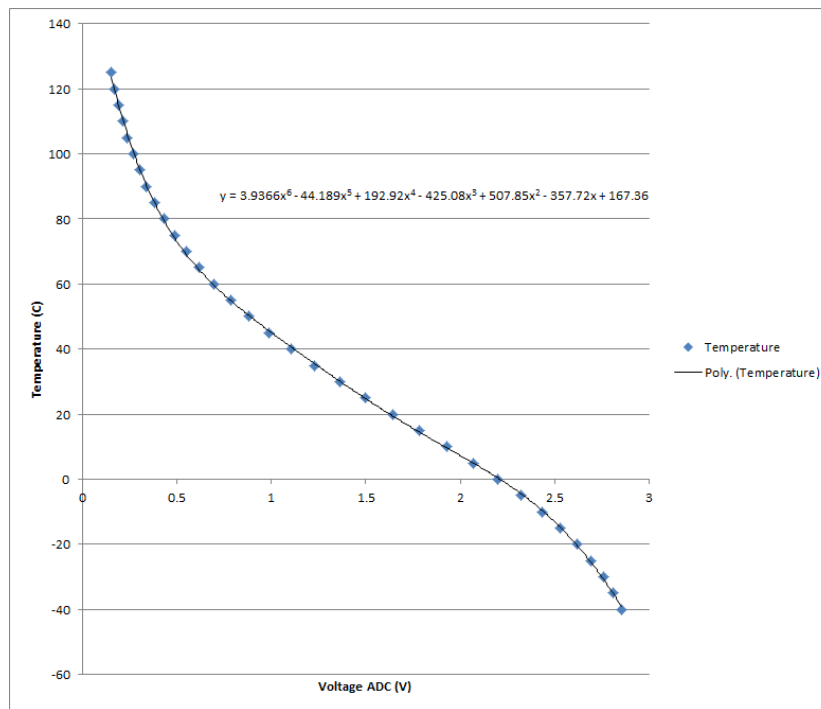

Figure 55. Typical Voltage ADC vs Thermistor Plot

4.10.2. Stack Current Calibration

Current measurements are made using a current sensing analog front-end (AFE) .

4.10.2.1. Stack Current Field Calibration

Units that have been factory locked may still require tuning for variability in shunts on a per-unit basis. The equation for Stack Current Field Calibration adjustment is:

$$I(\text{rawcurrent}) = \text{rawcurrent} \left(1 + \frac{\text{gain}}{100000} \right)$$

The gain is set in the configuration as follows.

`stack_power.current_gain` (Configuration)

- Fine tuning gain for raw current values.
- A value of 1000 = +1% adjustment ($\text{rawcurrent} * 1.01$)
- A value of -1000 = -1% adjustment ($\text{rawcurrent} * 0.99$).

At the factory, appropriate limits for the gain are defined to ensure a user does not misconfigure the system. The gain limit is set in the configuration as follows:

`stack_power.current_gain_limit` (Factory)

- Absolute value of the limit for gains on raw current values.
- If the `stack_power.current_gain` register is set to outside of this limit, the gain applied will be limited to this value.



Nuvation Energy has pre-calibrated each G5 Stack Switchgear with its own gain and limit. Each unit will have its own set of calibrations which must be maintained when applying an upgrade or configuration update. Make sure to capture and record the calibration of each unit for this purpose. If you have lost this calibration information, please contact support@nuvationenergy.com with the serial number(s) to retrieve this data.

4.10.2.2. DC Bus Current Field Calibration

There is an equivalent calibration for the DC Bus current similar to [Section 4.10.2.1, "Stack Current Field Calibration"](#) but uses the following configurable gain and limit:

`ssg_bus_power.current_gain` (Configuration)

- Fine tuning gain for raw current values.
- A value of 1000 = +1% adjustment ($\text{rawcurrent} * 1.01$)
- A value of -1000 = -1% adjustment ($\text{rawcurrent} * 0.99$).

At the factory, appropriate limits for the gain are defined to ensure a user does not misconfigure the system. The gain limit is set in the configuration as follows:

`ssg_bus_power.current_gain_limit` (Factory)

- Absolute value of the limit for gains on raw current values.
- If the `ssg_bus_power.current_gain` register is set to outside of this limit, the gain applied will be limited to this value.

4.10.2.3. Charge Deadband Setting

In addition to calibrating current readings, it is also necessary to define the deadband that will be used to determine whether the battery stack is charging, discharging, or at rest (holding).

`stack_charge_status.hold_current` (Factory)

- The battery stack is considered at rest unless the absolute value of current exceeds this threshold
- Set as required by application (typically between 50 and 100 mA)

While this threshold is used to qualify certain aspects of SoC estimation, Coulomb counting takes place continuously regardless of the configured hold current value. Other functions that require knowledge of the charge or discharge state of the stack (e.g. the thermistor temperature thresholds) also make use of this threshold.

4.10.3. Stack Voltage Calibration

Stack voltage measurements are made using a voltage sensing analog front-end (AFE) that must be configured for Nuvation Energy BMS.

4.10.3.1. Stack Voltage Field Calibration

Units that have been factory locked may still require tuning for variability on a per-unit basis. The equation for Stack Voltage Field Calibration adjustment is:

$$V(\text{rawvoltage}) = \text{rawvoltage} \left(1 + \frac{\text{gain}}{100000} \right)$$

The gain is set in the configuration as follows.

`stack_power.voltage_gain` (Configuration)

- Fine tuning gain for raw voltage values. A value of 1000 = +1% adjustment (`rawvoltage * 1.01`). A value of -1000 = -1% adjustment (`rawvoltage * 0.99`).

At the factory, appropriate limits for the gain are defined to ensure a user does not misconfigure the system. The gain limit is set in the configuration as follows:

`stack_power.voltage_gain_limit` (Factory)

- Absolute value of the limit for gains on raw voltage values.
- If the `stack_power.voltage_gain` register is set to outside of this limit, the gain applied will be limited to this value.



Nuvation Energy has pre-calibrated each G5 Stack Switchgear with its own gain and limit. Each unit will have its own set of calibrations which must be maintained when applying an upgrade or configuration update. Make sure to capture and record the calibration of each unit for this purpose. If you have lost this calibration information,

please contact support@nuvationenergy.com with the serial number(s) to retrieve this data.

4.10.3.2. DC Bus Voltage Field Calibration

There is an equivalent calibration for the DC Bus voltage similar to [Section 4.10.3.1, "Stack Voltage Field Calibration"](#) but uses the following configurable gain and limit:

`ssg_bus_power.voltage_gain` (Configuration)

- Fine tuning gain for raw voltage values.
- A value of 1000 = +1% adjustment ($\text{rawvoltage} * 1.01$)
- A value of -1000 = -1% adjustment ($\text{rawvoltage} * 0.99$).

At the factory, appropriate limits for the gain are defined to ensure a user does not misconfigure the system. The gain limit is set in the configuration as follows:

`ssg_bus_power.voltage_gain_limit` (Factory)

- Absolute value of the limit for gains on raw voltage values.
- If the `ssg_bus_power.voltage_gain_limit` register is set to outside of this limit, the gain applied will be limited to this value.

4.11. Hardware Settings

4.11.1. Link Bus Scan Period

The rate at which cell voltage and temperature measurements are updated is determined by a configurable *Link Bus* scan period. All cell voltages are measured every scan cycle. Thermistor temperature measurement is multiplexed across eight consecutive scan cycles. One thermistor in each group of cells (monitored by a single BMS module) is measured during each cycle, so the effective scan period of any given thermistor in the system is 8 times the *Link Bus* scan period.

`sc_linkbus.scan_period`

- Measurement period for cell voltages
- This is typically set to 1 second

Performance of passive balancing is also closely related to the scan period. In Nuvation Energy BMS, a single wiring harness is used to measure cell voltage as well as bleed off passive cell balancing current. It is not possible to make accurate voltage measurements while simultaneously balancing cells. To ensure accurate measurement, balancing current flow must stop before measurement can start (and any transient effects associated with that current flow must be allowed to settle). This is handled automatically by Nuvation Energy BMS. This means that passive balancing has some duty cycle that is less than 100% in practical systems.

The *Link Bus* has a configurable settling period for balancing that corresponds to the amount of time balancing is left off before voltage measurements are taken.

`sc_linkbus.balance_settle_period`

- Settling period during which balancing is disabled before cell voltage measurement.
- Typically set between 50 and 100 ms

For most systems, values between 50 and 100 ms yield accurate, stable measurements. When coupled with a scan period of 1000 ms, balancing duty cycles above 90% are achievable.

For some applications, it may be desirable to de-rate the effective passive balancing current by increasing the balancing settling period as a way to decrease the balancing duty cycle. If the balancing settling period is increased beyond the scan period, the actual scan rate of the system will start to decrease below the configured value.

The actual *Link Bus* scan period can be observed by reading the register:

`sc_linkbus.actual_scan_period`

- Actual measured scan period of the *Link Bus*
- Value should be approximately equal to the desired scan period configured in `sc_linkbus.scan_period`

4.11.2. Cell Voltage Low-Pass Filter

One of two low-pass filters (LPF) are available for cell voltage measurement. This cell voltage low-pass filter is also referred to as the 'Measurement Anti-Aliasing Filter'. The filters are implemented in hardware and are selected via the following configuration.

`sc_linkbus.cell_voltage_lpf_bw`

- A value of 0 selects a 7 kHz LPF (i.e OFF)
- A value of 1 selects a 26 Hz LPF (i.e. ON)

4.11.3. Cell Open Wire Detection and Diagnostics

The Battery Management System is capable of detecting wiring and circuit problems on each cell voltage channel. The following scenarios are detectable:

- Open circuits
- Short circuits
- High impedance connections/wiring
- Internal Battery Management System hardware failures

All installed channels are scanned for wiring and circuit problems when the Battery Management System is not in [Service Lockout](#) and its contactors are closed. Open wires and circuit problems are reported for each cell through the `cell.open_wire` flag. The common configurable settings for open wire detection on all modules are listed and described below.

`sc_linkbus.cell_open_wire_disabled`

- Typically this is set to 0

- Setting this to 1 will disable all open wire reporting

`sc_linkbus.cell_open_wire_period`

- The configurable period for scanning all channels for open wires
- Typically this is set to 3600000000 (one hour)



Open wires are only scanned according to this period when the batteries are connected to the DC bus during typical operation.

`sc_linkbus.cell_open_wire_thresh`

- The configurable count for positive open wire detections before the `cell.open_wire` flag is set
- This is to ensure noise triggered false positives are filtered
- Typically this is set to 3

`sc_linkbus.cell_open_wire_max`

- The configurable maximum count for positive open wire detections
- This variable is used to prevent windup of each channel's counter
- It also dictates how many *Link Bus* scan cycles should be used to collect enough samples to detect open wires
- Typically set to 10 and cannot be less than `sc_linkbus.cell_open_wire_thresh`

For systems using G5 Cell Interface - 24 channel modules, the configurable settings are listed and described below.

`sc_linkbus.cell_open_wire_ratio_lower`

- The ratio below which the channel has an error, represented as an integer between 0 and 1000, (0 = 0.0, and 1000 = 1.0)
- Channels that have low ratios are indicative of high impedance connections between the cell and channel input, possibly due to loose connections or bad terminals.
- Very low ratios indicate an open wire or a Battery Management System hardware failure
- Typically set to 800, representing 0.8

`sc_linkbus.cell_open_wire_ratio_upper`

- The ratio above which the channel has an error, represented as an integer between 0 and 1000, (0 = 0.0, and 1000 = 1.0)
- Channels that have high ratios are indicative of either short circuits or a Battery Management System hardware failure
- This is typically 970, representing 0.97

4.11.4. Fault Pilot

The *Fault Pilot* refers to internal hardware control for the Nuvation Energy BMS that is used to open the contactors through a secondary control path in the case of a fault condition. When the system is faulted, the *Fault Pilot* will guarantee that the contactor coils are de-energized, regardless of the state

of the coil control software.

In most applications, the *Fault Pilot* operates as a delayed version of the overall fault state of the BMS. This small delay allows for the opening of contactors according to any delays configured as part of the contactor output settings ([Section 4.7.2, "Contactor Configuration"](#)).

In Nuvation Energy G5 Stack Switchgear systems, the fault pilot is an internal service that periodically arms an external watchdog timer which when expires will de-energize contactors.

`sc_gpo_fault_pilot.fault_enabled`

- Set to 1 to enable Fault Pilot to assert when `stack_factory_trigger_summary.fault` is tripped

`sc_gpo_fault_pilot.fault_delay`

- Set according to application (typically, between 100 and 5000 ms)

4.11.5. Under-Voltage Lockout

Some Battery Management System products have the hardware feature to shut off the power when the battery is at a critically low voltage level. This feature is referred to as a Under-Voltage Lockout (UVLO).

The Under-Voltage Lockout feature integrates with the same mechanism used by the Shutdown input of the G5 High-Voltage BMS ([Shutdown Input](#)). When a UVLO condition is detected the Nuvation Energy BMS will initiate its own shutdown.



The Enable input ([Enable Input](#)) can be asserted to override the UVLO feature and keep the Nuvation Energy BMS powered on to address the UVLO condition. It is possible to configure the Battery Management System to allow the contactors to close and charge the battery from this critically low state. Please contact support@nuvationenergy.com for assistance.



The UVLO feature must be enabled via a hardware setting as mentioned in [Section 3.3.3.9, "Set the Config Switches"](#). If this hardware configuration is not completed then the G5 High-Voltage BMS will not be able to power itself off. The state of this configuration can be read through the register `ssg_uvlo_enable.value`. A value of 1 indicates UVLO is enabled and a value of 0 indicates UVLO is disabled.

4.11.5.1. Configuration

The following registers need to be configured to manage this feature. A combined Under Voltage Lock Out (UVLO) trigger is used to provide a shutdown input for either a critically low stack or cell voltage.

`stack_trig_uvlo_cell_voltage.thresh`

- Set to a cell voltage that is greater than `stack_fault_cell_under.thresh` and less than `stack_fault_cell_lo.thresh`.

`stack_trig_uvlo_stack_voltage.thresh`

- Set to a stack voltage that is greater than `stack_fault_voltage_under.thresh` and less than

`stack_fault_voltage_lo.thresh.`

The above triggers are logically OR'd together into a combined trigger named `stack_uvlo_combined`. The output of this trigger needs to be directed to the internal shutdown of the G5 High-Voltage BMS using the following register configuration.

`sc_gpo_shutdown.address`

- Set to `@stack_uvlo_combined.trig`

`sc_gpo_shutdown.inverted`

- Set to 1

`sc_gpo_shutdown.address_enabled`

- Set to 1



When UVLO is disabled, set both registers `sc_gpo_shutdown.address` and `sc_gpo_shutdown.address_enabled` to zero.

4.11.6. Clock Verification

The G5 Stack Switchgear will perform periodic self checks for its internal clocks to ensure proper operation. The following components are associated with clock checking diagnostics.

`sc_fault_clocks.disabled`

- Setting to 1 enables clock checking on the G5 Stack Switchgear
- Disabling this fault will prevent the BMS from opening contactors if the G5 Stack Switchgear detects that the unit's internal clock is not operating properly.

4.11.7. Shorted Shunt Detection

The short circuit failure modes and/or wiring defects of the current shunt are detected by correlating the internal fuse temperature with the current measurement. When there is a lack of correlation between these measurements a shorted shunt fault is triggered. [Table 37, "Configuration Register Settings for Shorted Shunt Detection"](#) lists the shorted shunt parameter settings according to the fuse rating which is identified by the part number as shown in [G5 Stack Switchgear Ordering Information](#) .

Table 37. Configuration Register Settings for Shorted Shunt Detection

Fuse Code	Fuse Rating	Minimum Detection Current (A)	Non-Steady-State Temperature Derivative Threshold	Steady-State Temperature Threshold
1	200	50	0.001	3
		75	0.00125	4
		100	0.0015	5
2	250	100	0.0015	6
		150	0.005	8
		200	0.007	20

Fuse Code	Fuse Rating	Minimum Detection Current (A)	Non-Steady-State Temperature Derivative Threshold	Steady-State Temperature Threshold
3	315	100	0.001	5
		200	0.008	15
4	350	150	0.0025	6
		200	0.005	15
		300	0.01	35
		350	0.01	40
5	400	200	0.005	15
		300	0.01	35
		350	0.01	35
6	450	200	0.005	12
		300	0.01	30
		350	0.01	35
7	500	200	0.004	10
		300	0.01	25
		350	0.01	35

The short shunt detection configurations are determined based on the G5 Stack Switchgear fuse rating and the battery’s current protection limits. To determine the appropriate threshold:

1. Determine the thresholds in the table above corresponding the Fuse Rating of the G5 Stack Switchgear
2. Determine the minimum current between `stack_fault_charge_current_over.thresh` and `stack_fault_discharge_current_over.thresh`
3. Within the determined Fuse Rating section of the table, select a row corresponding to a Minimum Detection Current that is **below or equal** the current determined in Step 2 to obtain the Non-Steady-State Temperature Derivative Threshold and the Steady-State Temperature Threshold

If a Minimum Detection Current below the battery current protection limits does not exist in the table above, a different Stack Switchgear fuse type needs to be selected OR the designer must provide a mitigation to their system to protect against continuous operation at currents between `stack_fault_discharge_current_over.thresh` or `stack_fault_charge_current_over.thresh` and the Minimum Detection Current.

4.11.8. Temperature Consistency Check

For each G5 Cell Interface - 24 channel module in the stack, the temperature consistency check will calculate the maximum deviation between the smallest and largest measured temperature.

If the deviation exceeds a configurable threshold value, a fault will be tripped.

`stack_fault_ci_therm_consistency.thresh`

- The maximum temperature deviation, in units of °C, that is allowed between thermistors of a single G5 Cell Interface - 24 channel module
- Typically this is set to 15

In order to minimize this temperature deviation and prevent false trips, consider the following recommendations below.

4.11.8.1. Recommendation for Temperature Consistency Check

There are two main factors that need to be considered when connecting the thermistors. First, it is important to ensure that the thermal cooling environment for each of thermistors is similar. One approach is to place the thermistors orthogonal to the cooling air direction.

Consider the following scenario where the cooling air flow is in the same direction as the installed thermistors.

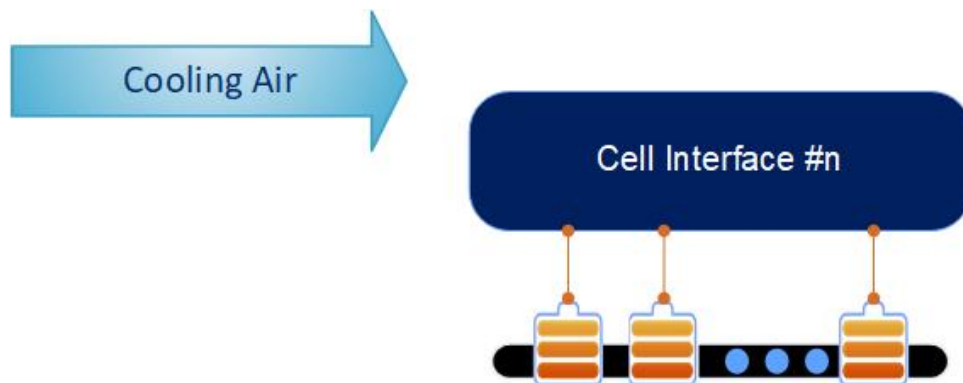

Figure 56. Thermistor arrangement scenario one

A temperature gradient will develop in the direction of the air flow, where the cells to the far left will be cooled more than the ones to the right. This can result in a large temperature deviation within the cell grouping. To minimize this, the cells can be rearranged as shown below.

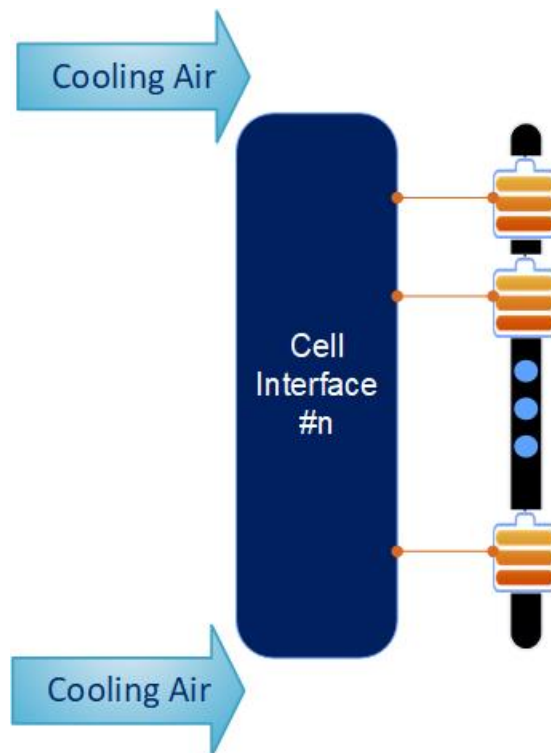

Figure 57. Thermistor arrangement scenario two

The effect of the temperature gradient can be attenuated by grouping thermistors orthogonal to the gradient. During operation, the temperature measurements within this group increase and decrease and therefore, when a failure occurs, the problematic thermistor will begin to deviate from the rest of the group.

A second factor that can be considered to minimize the temperature deviation within cell grouping is battery State-of-Health. It is advantageous to group cells with similar State-of-Health values together since they would have similar thermal responses to current activity.

4.11.9. Contactor Life Tracking

Nuvation Energy BMS provides a mechanism to track the life of each contactor and to trigger a fault when it is end-of-life. The life of each contactor at any given time is determined by the various opening currents the contactor has experienced. Each contactor can be individually configured for contactor life tracking where `ssg_contactor_monitor[n]` and `ssg_contactor_life_tracker[n]` corresponds to `stack_contactor[n]`.

Typically, a contactor will specify the number of make/break cycles it is rated for within a current range. For example, if contactor XYZ has the following ratings:

- 1000V, 200A max, 50 cycles make/break
- 1000V, 100A max, 6000 cycles make/break

Depending on the application, it may be safe to assume that above a number of rated make/break cycles, contactor life tracking is not required. In this example, we will assume that anything above

6000 cycles does not need to be tracked.

This will translate to the following contactor life tracking configuration:

- `ssg_contactor_life_tracker[0].enabled = 1`
- `ssg_contactor_life_tracker[0].min_opening_current = 100`
- `ssg_contactor_life_tracker[0].max_opening_current = 200`
- `ssg_contactor_life_tracker[0].max_rated_current = 199`
- `ssg_contactor_life_tracker[0].max_life = 50`



Consult the Nuvation Energy G5 High-Voltage BMS: NUVG5 Datasheet for specifications on contactor life ratings of your product model.

A complete list of all contactor life tracking registers is shown below.

`ssg_contactor_life_tracker[n].enabled`

- Set to 1 to enable contactor life tracking for contactor n

`ssg_contactor_life_tracker[n].current_capture_window`

- Window of current samples to consider for an opening current, centered around when the contactor opens. The largest value in this window is used
- Typical value is 2000000 (2 seconds). This would mean current measurements taken 1 second before and 1 second after the contactor opening event will be considered

`ssg_contactor_life_tracker[n].min_opening_current`

- Minimum opening current, above which the contactor life will increment
- This is typically set to the minimum current at which the contactor make/break cycles is limited

`ssg_contactor_life_tracker[n].max_opening_current`

- Maximum opening current, above which the contactor is immediately considered end-of-life

`ssg_contactor_life_tracker[n].max_rated_current`

- Current to assume the contactor opened at if the opening event could not be monitored
- Typically set to between `ssg_contactor_life_tracker[n].min_opening_current` and `ssg_contactor_life_tracker[n].max_opening_current`

`ssg_contactor_life_tracker[n].max_life`

- Maximum life of the contactor, above which the contactor is considered end-of-life
- This should be set to the number of make/break cycles the contactor is rated for between `ssg_contactor_life_tracker[n].min_opening_current` and `ssg_contactor_life_tracker[n].max_opening_current`

`ssg_warn_contactor_end_of_life.thresh`

- The threshold below which a warning is triggered around the contactor's remaining life
- This value is a Percentage, indicating the remaining life of the contactor

`ssg_fault_contactor_end_of_life.thresh`

- The threshold below which a fault is triggered around the contactor’s remaining life
- This value is a Percentage, indicating the remaining life of the contactor. This should be set to 0

Please contact support@nuvationenergy.com if this feature is required for your application’s functional safety.

4.12. Watchdogs and Freshness

Watchdog timers are employed in Nuvation Energy BMS to ensure specific functions execute regularly. If a watchdog timer is not periodically reset, the timer will expire and an associated fault will trip and disconnect the contactors. The watchdog timers are exposed by the BMS through multiple watchdog components.

`wdt.expired`

- 1 indicates that the timer has not been reset within the configured time and is considered expired
- 0 indicates the timer has not expired.

`wdt.period`

- The time period within which the timer needs to be reset before it expires

The watchdogs configurations are described below.

Table 38. Nuvation Energy BMS Watchdog Components

Watchdog Component	Notes
<code>sc_ram_test_wdt</code>	Configures the watchdog timer for the RAM testing. Typically period is 60000000 (60 s).
<code>sc_rom_test_wdt</code>	Configures the watchdog timer for the ROM testing. Typically period is 60000000 (60 s).
<code>sc_controller_wdt</code>	Configures the watchdog timer for the external controller update. The period is dependant on the responsiveness to external controller to periodically update the BMS watchdog.

4.12.1. Freshness

Freshness is a mechanism in Nuvation Energy BMS to guarantee data within the system is up to date.

Measurements such as cell voltage, cell temperatures, and stack voltage are captured on the G5 Cell Interface modules and the G5 Stack Switchgear. Points of failures on the G5 Cell Interface modules, internal measurements of the G5 Stack Switchgear or on the Link Bus can result in data reported by the BMS to be stale.

Regardless of how and where data stops being propagated, freshness provides a mechanism for the system to detect these failures and perform the necessary procedures to keep the system safe.

The freshness mechanism is exposed by the BMS through multiple freshness component.

fresh.stale

- 1 indicates that the associated data has not been updated within the configured time and is considered stale
- 0 indicates the data is still fresh

fresh.period

- The time period within which the associated data needs to be updated before it is considered to be stale

Freshness components are mapped to certain types of data such as cell data, stack data, and so on. When a freshness component becomes stale, it means that its associated data has not been updated within the configured time period.

Table 39. Nuvation Energy BMS Freshness Components

Freshness Component	Associated Data	Notes
stack_cell_fresh	cell.voltage cell.open_wire	Ensures cell information is updated. Only installed cells are checked for freshness. The period must be longer than <code>sc_linkbus.scan_period</code> , typically 3000000 (3 seconds).
stack_therm_fresh	therm.temperature therm.circuit_fail	Ensures thermistor information is updated. Only installed thermistors are checked for freshness. The period must be longer than 8x <code>sc_linkbus.scan_period</code> , typically 10000000 (10 seconds).
sc_ci_fresh	ci.supply_error ci.mux_error	Ensures Cell Interface operational information is updated. Only installed Cell Interface modules are checked for freshness. The period must be longer than <code>sc_linkbus.scan_period</code> , typically 3000000 (3 seconds).
sc_ci_therm_mux_test_fresh	ci.mux_test_failures	Ensures thermistor multiplexer testing occurs periodically. The period is typically set to 60000000 (60 seconds).
sc_ci_internal_temps_fresh	ci.ci_temperature_1 ci.ci_temperature_2	Ensures thermistor multiplexer testing occurs periodically. The period must be longer than <code>sc_linkbus.scan_period</code> , typically 3000000 (3 seconds).
stack_cell_open_wire_fresh	stack_cell_summary_stat.cell_open_wir e_executions	Ensures open-wire detection occurs periodically. The period must be set longer than <code>sc_linkbus.cell_open_wire_period</code> , typically 120000000 (120 seconds).

Freshness Component	Associated Data	Notes
stack_power_fresh	stack_power.voltage stack_power.current	Ensures stack power information is updated. The period must be set longer than pi_afe.sample_period, typically 60000000 (60 seconds).
stack_linkbus_fresh	sc_linkbus.power_error	Ensures Link Bus checks occur periodically. The period must be longer than sc_linkbus.scan_period, typically 3000000 (3 seconds).
sc_factory_verify_fresh	sc_factory_persist.verification_error	Ensures factory configuration verification of the stack controller subsystem occurs periodically. Ensures G5 Stack Switchgear factory configuration verification occurs periodically. The period is typically 60000000 (60 seconds).
ssg_contactor_life_verify_fresh	ssg_contactor_life_persist.verification_error	Ensures verification of the contactor life data occurs periodically. The period is typically 60000000 (60 seconds)
ssg_contactor_end_of_life_fresh	ssg_contactor_life_tracker_summary.min_life_remaining	Ensures contactor life is evaluated periodically. The period is typically 60000000 (60 seconds)
ssg_afe_fresh	afe_monitor.rx_count	Ensures verification of the AFE communication is executing periodically. The period is typically 2000000 (2 seconds)
ssg_afe_cpu_bist_fresh	afe_monitor.cpu_bist_update_time	Ensures verification of the AFE CPU built-in-test data is updated periodically. The period is typically 2000000 (2 seconds)
ssg_afe_ram_bist_fresh	afe_monitor.ram_bist_update_time	Ensures verification of the AFE RAM built-in-test data is updated periodically. The period is typically 2000000 (2 seconds)
ssg_afe_rom_bist_fresh	afe_monitor.rom_bist_update_time	Ensures verification of the AFE ROM built-in-test data is updated periodically. The period is typically 2000000 (2 seconds)
ssg_afe_thermistor_bist_fresh	afe_monitor.thermistor_bist_update_time	Ensures verification of the AFE thermistor built-in-test data is updated periodically. The period is typically 60000000 (60 seconds)
ssg_current_measurement_fresh	stack_power.current ssg_bus_power.current	Ensures verification of both current measurements are updated periodically. The period is typically 2000000 (2 seconds)

Freshness Component	Associated Data	Notes
ssg_therms_fresh	ssg_power_connector_therms.temperature ssg_ambient_therm.temperature ssg_shunt_therm.temperature ssg_fuse_therm.temperature	Ensures verification of all internal SSG temperature measurements are updated periodically. The period is typically 2000000 (2 seconds)
ssg_voltage_measurement_fresh	stack_power.voltage ssg_bus_power.voltage	Ensures verification of both voltage measurements are updated periodically. The period is typically 2000000 (2 seconds)
stack_cell_balancing_throttling_fresh	cell_balancing_throttling.disable_balancing_thermal	Ensures verification of data used to determine cell balancing throttling are updated periodically. The period must be longer than sc_linkbus.scan_period, typically 2000000 (2 seconds).
stack_cell_soc_distribution_fresh	cell_soc_distribution.soc_mean cell_soc_distribution.soc_interval_width	Ensures verification of data used to determine cell imbalance estimates used for continuous balancing are updated periodically. The period must be longer than sc_linkbus.scan_period, typically 1000000 (1 seconds).

5. Operating Instructions

5.1. Operating Limits

5.1.1. G5 Stack Switchgear



Exceeding the ratings will damage the system.

5.1.1.1. External Specifications

Symbol	Parameter	Min	Typ	Absolute Max	Units
V_{input_AC}	Input Voltage AC	100	-	240	V AC
f_{input_AC}	Input Frequency	45	50/60	65	Hz
V_{input_DC}	Input Voltage DC	21	24	27	V DC
P_{input_AC}	AC Input Power for BMS	-	24	88	W
P_{input_DC}	DC Input Power for BMS	-	10	50	W
V_{fan_DC}	Cooling Fan DC Voltage	-	-	27	V DC
V_{fan_AC}	Cooling Fan AC Voltage	-	-	250	V AC
P_{fan_DC}	Cooling Fan Power	-	-	96	W
P_{fan_AC}	Cooling Fan Power	-	-	120	W
$P_{total-input_AC}$	Total Input Power for BMS and Fan	-	-	144	W
$P_{total-input_DC}$	Total Input Power for BMS and Fan	-	-	106	W
GPI and Enable/Shutdown/Disconnect Specifications					
I_{max}	On Current	10	12	15	mA DC
V_{max}	Off Voltage	-	-	27	V DC
GPO Specifications					
V_{max}	Open Blocking Voltage	-	-	60	V DC
I_{max}	Closed Maximum Current	-	-	400	mA DC
R_{on}	Closed-State Resistance	-	-	2	Ω

5.1.1.2. Electrical Characteristics

The part number of the G5 Stack Switchgear captures its product rating. The voltage rating is an absolute maximum rating, and the current rating is a continuous rating (also referred to as the 'nominal' rating). Input power is internally regulated to be compliant with NEC class 2 requirements.

Part number format: NUVG5-SSG-<absolute-max-voltage>-<continuous-current-rating>-<fuse-rating> For the fuse rating, please see [Table 69, "Fuse rating and code"](#).

Voltage and Temperature Specifications

Table 40. Voltage and Temperature Sensor Specifications for all Configurations

Symbol	Parameter	Min	Typ	Absolute Max	Units
Battery Stack Specifications					
V_{stack_ov}	Stack Over-Voltage Threshold (triggers contactors to open)	-	<i>configurable</i>	1500	V DC
V_{stack_uv}	Stack Under-Voltage Threshold (triggers contactors to open)	-	<i>configurable</i>	-	V DC
Battery Cell Specifications					
C_{ov}	Cell Over-Voltage Threshold (triggers contactors to open)	-	<i>configurable</i>	-	V
C_{uv}	Cell Under-Voltage Threshold (triggers contactors to open)	-	<i>configurable</i>	-	V
Temperature Sensors Specifications					
T_{ut}	Under-Temperature Thresholds Charge/Discharge (triggers contactors to open)	-	<i>configurable</i>	-	°C
T_{ot}	Over-Temperature Thresholds Charge/Discharge (triggers contactors to open)	-	<i>configurable</i>	-	°C
T_{fan_en}	Fan Enable Temperature Thresholds Charge/Discharge	-	<i>configurable</i>	-	°C

Table 41. Overvoltage Category Specifications for all Configurations

Symbol	Parameter	Absolute Max	Units
CAT _{II}	Phase to Ground Rated System Voltage (RMS or DC)	1000	V
CAT _{III}	Phase to Ground Rated System Voltage (RMS or DC)	600	V

Continuous and Maximum Current Ratings

Table 42. Maximum Rated Current : NUVG5-SSG-1500-200-x

Symbol	Parameter	Continuous	Absolute Max	Units
$I_{discharge_oc}$	Stack Discharging Over-Current (triggers contactors to open)	200	250	A DC
I_{charge_oc}	Stack Charging Over-Current (triggers contactors to open)	200	250	A DC

Table 43. Maximum Rated Current: NUVG5-SSG-1500-300-x

Symbol	Parameter	Continuous	Absolute Max	Units
$I_{discharge_oc}$	Stack Discharging Over-Current (triggers contactors to open)	300	350	A DC
I_{charge_oc}	Stack Charging Over-Current (triggers contactors to open)	300	350	A DC

Table 44. Maximum Rated Current: NUVG5-SSG-1500-350-x

Symbol	Parameter	Continuous	Absolute Max	Units
$I_{discharge_oc}$	Stack Discharging Over-Current (triggers contactors to open)	350	400	A DC
I_{charge_oc}	Stack Charging Over-Current (triggers contactors to open)	350	400	A DC



The G5 Stack Switchgear can handle short current overages above the continuous rating. Any charge or discharge current above the continuous rating must not exceed 5 minutes per hour and must not exceed the specified absolute max rating. Sufficient time to allow the system to cool down afterward is required.

Contactor Life Ratings

Table 45. Contactor Life Ratings : NUVG5-SSG-1500-200-x

Symbol	Parameter	Min	Max	Absolute Max	Units
$I_{min_breaking}$	Minimum breaking current of contactors	200	-	-	A DC
N_{min}	Number of contactor opening cycles below the minimum breaking current	6000	-	-	cycles
$I_{max_breaking}$	Maximum breaking current of contactors	-	250	-	A DC
N_{life}	Number of contactor opening cycles between the minimum and maximum breaking currents	-	50	-	cycles
N_{max}	Number of contactor opening cycles above the maximum breaking current	-	1	-	cycle
I_{max}	One time contactor maximum breaking current	-	-	1500	A DC

Table 46. Contactor Life Ratings : NUVG5-SSG-1500-300-x

Symbol	Parameter	Min	Max	Absolute Max	Units
$I_{min_breaking}$	Minimum breaking current of contactors	200	-	-	A DC
N_{min}	Number of contactor opening cycles below the minimum breaking current	6000	-	-	cycles
$I_{max_breaking}$	Maximum breaking current of contactors	-	350	-	A DC
N_{life}	Number of contactor opening cycles between the minimum and maximum breaking currents	-	50	-	cycles
N_{max}	Number of contactor opening cycles above the maximum breaking current	-	1	-	cycle
I_{max}	One time contactor maximum breaking current	-	-	1500	A DC

Table 47. Contactor Life Ratings : NUVG5-SSG-1500-350-x

Symbol	Parameter	Min	Max	Absolute Max	Units
$I_{min_breaking}$	Minimum breaking current of contactors	200	-	-	A DC
N_{min}	Number of contactor opening cycles below the minimum breaking current	6000	-	-	cycles
$I_{max_breaking}$	Maximum breaking current of contactors	-	400	-	A DC
N_{life}	Number of contactor opening cycles between the minimum and maximum breaking currents	-	10	-	cycles
N_{max}	Number of contactor opening cycles above the maximum breaking current	-	1	-	cycle
I_{max}	One time contactor maximum breaking current	-	-	1500	A DC



To extend the lifetime of the G5 Stack Switchgear a disconnect delay can be configured to allow time for the PCS controller to reduce the current flowing through the battery stack before the G5 Stack Switchgear will open contactors, which will avoid exposing the contactors to high breaking currents.



Contactors will open immediately for the following conditions which will bypass the disconnection delay:

1. Unpowering the G5 Stack Switchgear.
2. Using the Fast Disconnect feature.

5.1.2. G5 Cell Interface



Exceeding the maximum ratings will damage the G5 Cell Interface module.

5.1.2.1. Electrical Characteristics

Symbol	Parameter	Conditions	Min	Typ	Absolute Max	Units
Link In Specifications						
I_{P_LINK}	Output Current	-	-	-	22	mA DC
I_{N_LINK}	Output Current	-	-	-	22	mA DC
Link Out Specifications						
I_{P_LINK}	Output Current	-	-	-	20	mA DC
I_{N_LINK}	Output Current	-	-	-	20	mA DC
Battery Cells Specifications						
$C_{(n)} - C_{(n-1)}$	Input Cell Voltage Range	-	1.6	-	4.3	V DC
V_{sum}	Voltage between C0 and C12		11.2	-	51.6	V DC
	Voltage between C12 and C24		11.2	-	51.6	V DC
I_{Active}	Between C0 and C12	Linkbus communication, $V_{sum} = 43.2V$	-	13	20	mA
	Between C12 and C24	Linkbus communication, $V_{sum} = 43.2V$	-	9	11	mA
$I_{Standby}$	Between C0 and C12	No Linkbus communication, $V_{sum} = 43.2V$	-	70	225	μA
	Between C12 and C24	No Linkbus communication, $V_{sum} = 43.2V$	-	70	225	μA
	Between $C_{(n)} - C_{(n-1)}$	No Linkbus communication, $V_{sum} = 43.2V$	-	1.2	15	μA
TME	Total Measurement Error		± 0.1	± 1.6	± 2.8	mV DC
$I_{(n)}$	Cell Balancing Current	$C_{(n)} - C_{(n-1)} = 4 V DC$	145	150	159	mA DC
V_{ins}	Internal reinforced insulation rating from Chassis/COM	-	-	-	1500	V DC
CAT _{II}	Overvoltage category	Phase to Ground Rated System Voltage (RMS or DC)	-	-	1000	V
CAT _{III}	Overvoltage category	Phase to Ground Rated System Voltage (RMS or DC)	-	-	600	V
Temperature Sensors Specifications						
$I_{(n)}$	Output Current to Temperature Sensor	-	-	-	300	μA
$R_{t(n)}$	Temperature Sensor Resistance at 25 °C	-	-	10	-	k Ω

Symbol	Parameter	Conditions	Min	Typ	Absolute Max	Units
$T_{(n)}$	Input Temperature Sensor Voltage Range	Cell 0 = 0 V	0	-	3	V
V_{ins}	Internal reinforced insulation rating from Chassis/COM	-	-	-	1500	V DC
CAT _{II}	Overvoltage category	Phase to Ground Rated System Voltage (RMS or DC)	-	-	1000	V
CAT _{III}	Overvoltage category	Phase to Ground Rated System Voltage (RMS or DC)	-	-	600	V

5.1.2.2. Maximum Stack Deployment

G5 Cell Interface modules are deployed as a daisy chain to monitor the cells of a stack. G5 Stack Switchgear can support a maximum of 20 G5 Cell Interface modules.

Limits Due to Cell Voltage Scan Rate

The required scan rate of the cell voltage measurements for a stack will determine the maximum number of G5 Cell Interface modules that the G5 Stack Switchgear can support for that stack configuration.

The following are approximate cell voltage scan rates for different lengths of G5 Cell Interface daisy chains where all cells are installed.

Table 48. Cell Voltage Scan Rates for CI-24

CI-24 Chain Length	Scan Rate [Hz]
1	4.43
5	3.20
10	2.38
15	1.88
20 (max)	1.51

5.1.3. Environmental Conditions

The Nuvation Energy G5 High-Voltage BMS environmental conditions are captured in the table below.

For transportation, it is recommended that the G5 Stack Switchgear be shipped in its original packaging via pallet whenever possible.

Symbol	Parameter	Min	Typ	Absolute Max	Units
Thermal Specifications					
T_a	Operating Temperature	-20	25	60	°C
	Storage Temperature	-30	25	60	°C

Symbol	Parameter	Min	Typ	Absolute Max	Units
Humidity Specifications					
RH	Operational Relative Humidity	5	-	85	%
	Storage Relative Humidity	5	-	85	%
Shock and Vibration Specifications					
Vertical	Vertical shock/vibration (SAE J2380)	-	-	10	m/s ²
Longitudinal	Longitudinal shock/vibration (SAE J2380)	-	-	10	m/s ²
Transverse	Transverse shock/vibration (SAE J2380)	-	-	10	m/s ²
Pulse vibration	On each axis (SAE J2464)	-	-	245	m/s ²
Altitude Specifications					
A _a	Operating Altitude	-	-	2000	m

5.2. Status LEDs

The status LEDs provide an indication of the functional status of the G5 Stack Switchgear. A more detailed status may be accessed via the G5 Operator Interface.

5.2.1. G5 Stack Switchgear Status LEDs

The G5 Stack Switchgear has several LEDs that are used for displaying information about the status of the BMS.

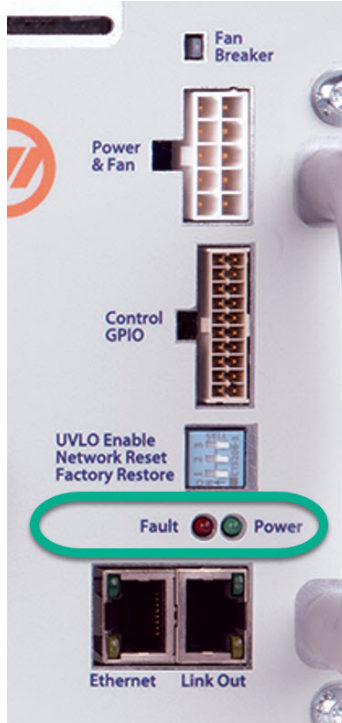

Figure 58. Fault and Power LEDs

Power LED

The **POWER** LED (green) provides information on the state of the G5 Stack Switchgear. Nominally, if this LED is *On* it indicates that the system is powered on.

Fault LED

The **FAULT** LED (red) provides information on the G5 Stack Switchgear status. Nominally, if this LED is *On* it indicates the G5 Stack Switchgear is faulted.



Figure 59. Ethernet and Linkbus LEDs

Link Out LEDs

There are two LEDs on the right side of the connector labelled 'Link Out' on the G5 Stack Switchgear.

The **BMS Activity** LED (green) provides information on the G5 High-Voltage BMS state.

This LED state combined with the Power, Fault and Link Activity LEDs states provide information on the G5 High-Voltage BMS state.

The **Link Activity** LED (amber) provides information on the G5 High-Voltage BMS state.

This LED state combined with the Power, Fault and Link Activity LEDs states provide information on the G5 High-Voltage BMS state.

Ethernet LEDs

There are two LEDs on the left side of the connector labelled 'Ethernet' on the G5 Stack Switchgear.

The upper LED is the *Activity* LED. A solid light means a connection between the devices. The LED will flash whenever data is being transmitted. No light means that there is no current connection.

The lower LED is the *Line Speed* indicator for Ethernet data speeds. It will be orange for 10 Mbit and green for 100 Mbit line speeds.

The ethernet LEDs are used only for displaying information on ethernet activity.

5.2.1.1. Determining BMS State from LED Status

The Fault, Power, BMS Activity and Linkbus Activity LED may be *On*, *Off*, *Blinking* or *Slow Blinking*. When *Blinking* the LED toggles *On/Off* with a 2 second period and 50% duty cycle. *Slow Blinking* has a ten second period with 50% duty cycle. *Blinking* and *Slow Blinking* states are not used with the Linkbus Activity, which toggles based on amount of traffic going over the linkbus. The following table provides a reference for determining the system status based on the state of the LEDs:

Table 49. G5 High-Voltage BMS State based on LED Status

Power LED	Fault LED	BMS Activity LED	Linkbus Activity LED	State Indication
<i>Off</i>	<i>Off</i>	<i>Off</i>	<i>Off</i>	BMS is unpowered
<i>On</i>	<i>Off</i>	<i>On</i>	N/A	BMS is Operational
<i>On</i>	<i>On</i>	<i>On</i>	N/A	BMS is Operational and faulted
<i>On</i>	<i>Off</i>	<i>Off</i>	N/A	BMS is in Service Lockout
<i>On</i>	<i>On</i>	<i>Blinking</i>	N/A	BMS is in Self Test
<i>On</i>	N/A	N/A	<i>Blinking</i>	Indicates Linkbus communicating
<i>On</i>	<i>On</i>	N/A	<i>On</i>	Indicates Linkbus Fault
<i>On</i>	N/A	N/A	<i>Off</i>	Indicates no Linkbus Communication
<i>Blinking</i>	<i>Off</i>	<i>Off</i>	<i>Off</i>	Unable to boot
<i>Blinking</i>	<i>Blinking</i>	<i>Off</i>	<i>Off</i>	Upgrading firmware
<i>Blinking</i>	<i>Off</i>	<i>Blinking</i>	<i>Off</i>	Network Config Reset
<i>Blinking</i>	<i>Blinking</i>	<i>Blinking</i>	<i>Off</i>	Network reset, restore factory firmware and configuration

Power LED	Fault LED	BMS Activity LED	Linkbus Activity LED	State Indication
<i>Blinking</i>	<i>Blinking</i>	<i>On</i>	<i>Off</i>	Network reset, restore factory firmware and configuration

5.3. Using the Operator Interface

Launch the Operator Interface by opening the Nuvation-Energy-Operator-Interface.html file in your web browser.



Browser Compatibility

The Operator Interface currently supports the most recent versions of Mozilla Firefox and Google Chrome. Other browsers such as Internet Explorer are not supported. Please install a supported browser before attempting to access the Operator Interface.

The Operator Interface will automatically attempt to connect to the default BMS IP (192.168.1.21) or the last successful BMS IP connection.

If the Operator Interface is unable to connect to the BMS at the assumed IP, a prompt to enter the BMS IP will be displayed. Ensure the computer IP address is on the same network as the BMS IP address. See [Section 3.5.2, "Setup PC Network Adapter"](#).

A screenshot of a web-based configuration interface for Nuvation Energy BMS. At the top, there is a header bar with the text "Nuvation Energy BMS" in blue and orange. Below the header, there are two input fields. The first is labeled "BMS IP Address:" and contains the text "http://192.168.1.21". The second is labeled "BMS Connection Timeout (seconds):" and contains the number "10". To the right of the second field is a small dropdown arrow icon. Below these fields is a "Save" button. At the bottom of the form area, there is a large, empty rectangular box.

5.3.1. The Dashboard Tab

The default tab of the Operator Interface is the Dashboard. The Dashboard contains a high-level overview on the state of the battery stack. This is the only page required for daily monitoring of the battery stack.

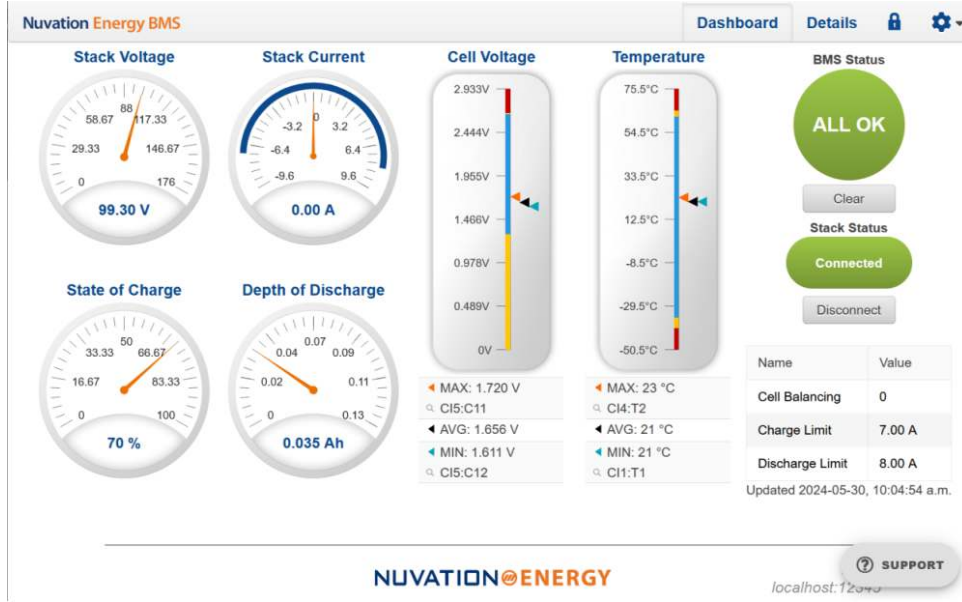

Figure 60. Nuvation Energy BMS Operator Interface Dashboard screenshot

5.3.1.1. Warnings and Faults

Before going into the details of the gauges and information presented in the dashboard, it is important to understand what a fault and a warning Nuvation Energy BMS status means.

	<p>An ALL OK indicates that there are no faults or warning. This is the normal state for Nuvation Energy BMS.</p>
	<p>A Warning indicates the state of the battery system has been detected outside of its normal operational range. The cause of the warning should be identified and a corrective action should be performed. For instance, if the warning is a thermistor temperature measurement has become too hot, the battery system should be cooled to bring the measurement back into the normal operational range.</p>
	<p>A Fault indicates the state of the battery system has been detected outside of its safe operational range. The cause of the fault must be identified and a corrective action must be performed. For instance, if the fault is a cell voltage measurement has become too low, the cell maintenance manual must be reviewed to identify what remedial actions are required.</p> <p>A Fault is more severe than a Warning and the source of the fault must be discovered and resolved before attempting to clear and continue operating the battery system.</p>

5.3.1.2. Stack Voltage

The stack voltage radial meter shows the total battery stack voltage.

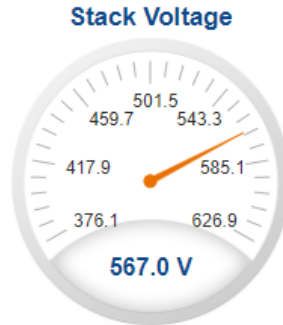

5.3.1.3. Stack Current

The stack current radial gauge shows the battery stack current as well as the maximum charge current limit and the maximum discharge current limit. The acceptable current range is visualized on the gauge by the blue arc. An absence of the blue arc indicates the battery stack cannot be charged or discharged in its present condition.

A negative current value indicates the battery stack is charging. A positive current value indicates the battery stack is discharging.



5.3.1.4. State-of-Charge

The State-of-Charge radial gauge shows the battery stack's State-of-Charge. The battery stack is empty when the State-of-Charge value is 0% and full when the State-of-Charge value is 100%.



5.3.1.5. Depth-of-Discharge

The Depth-of-Discharge radial gauge shows how much energy has been taken out of the battery stack. In an ideal Energy Storage System, defined as a system with no power losses, the amount of energy shown in this gauge needs to be added back into the battery stack to fill it back up to 100% State-of-Charge.

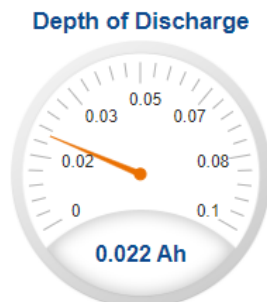

5.3.1.6. Cell Voltage

The cell voltage bar gauge shows the maximum, minimum, and average cell voltage measurements within the stack.

The high cell voltage and low cell voltage warning and fault threshold is visualized on the gauge with yellow and red segments. The blue segment depicts the acceptable cell voltage range.

If a triangle enters the yellow segment, a warning has occurred. If a triangle enters the red segment, a fault has occurred.

The maximum and minimum cell location in the stack and their voltage values are shown below the gauge, along with the average cell voltage value.

Cell Voltage

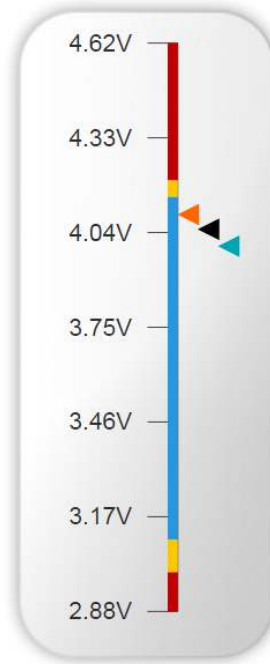

◀	MAX: 4.095 V
🔍	CI1:C3
◀	AVG: 4.05 V
◀	MIN: 3.998 V
🔍	CI1:C1

5.3.1.7. Temperature

The temperature bar gauge shows the maximum, minimum, and average cell temperature measurements within the stack.

The high cell temperature and low cell temperature warning and fault threshold is visualized on the gauge with yellow and red segments. The blue segment depicts the acceptable cell temperature range.

If a triangle enters the yellow segment, a warning has occurred. If a triangle enters the red segment, a fault has occurred.

The maximum and minimum cell location in the stack and their temperature values are shown below the gauge, along with the average cell temperature value.

Temperature

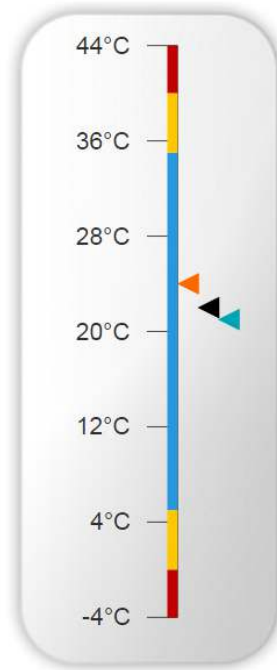

◀ MAX: 24 °C

🔍 CI7:T3

◀ AVG: 22 °C

◀ MIN: 21 °C

🔍 CI10:T4

5.3.1.8. Nuvation Energy BMS Status

Nuvation Energy BMS status information contains information on the overall safety status of the battery stacks, the battery stack connection state, number of cells balancing, maximum charge current limit, maximum discharge current, and the time and date of the last update of the Dashboard.

Operation Status

Nuvation Energy BMS operation state is shown in the big status circular indicator.



Figure 61. Three possible Nuvation Energy BMS operation states

The normal state is All OK and the color of the indicator will be green. The warning state is Warning and the color of the indicator will be orange. The fault state is Fault and the color of the indicator will be red.

Clicking on the indicator will jump to a comprehensive status list of warnings and faults active in the battery stack.

Clicking on the Clear button below the state will cancel any warnings and faults that are not self-clearing.

Connection State

The battery stack connection state is shown in the oval indicator.



Figure 62. Three possible connection states

Stack Disconnected in a red oval indicates the SSG contactors are open, and the battery stack is unavailable to be charged or discharged.

Stack Pre-charging in an orange oval indicates the battery stack has connected its pre-charge circuit and is attempting to equalize the battery stack voltage to the system DC bus voltage.

Stack Connected in a green oval indicates the battery stack is available to be charged or discharged.

Clicking the Connect button initiates the stack connection sequence of events. Nuvation Energy BMS must be in the All OK state for the Connect button to be available.

Clicking the Disconnect button will disconnect the battery stack from the system DC bus.

Information Table

The information table shows the number of cells that are having excess energy bled off to maintain a balanced battery stack.

Name	Value
Cell Balancing	15
Charge Limit	7.00 A
Discharge Limit	8.00 A

The Charge Limit shows the maximum charge current limit value. The Discharge Limit shows the maximum discharge current limit value.

The Charge Limit and Discharge Limit values are visualized on the Stack Current radial gauge as the limits of the blue arc.

Last Update

The Updated time and date shows the last time the Operator Interface had successfully communicated with Nuvation Energy BMS and updated all items in the Dashboard with values from Nuvation Energy BMS. The time and date is based on the local computer/tablet; it does not come from Nuvation Energy BMS.

If the communication with a Nuvation Energy BMS is lost, a notification banner appears at the top of the display screen. The information shown on the Dashboard represents the last data received and is no longer recent.

5.3.2. The Details Tab

The Details tab contains a much more detailed view into the status of Nuvation Energy BMS. The data values shown in this tab can be easily copied into a spreadsheet as a means of capturing the current state of Nuvation Energy BMS for manual data recording purposes.

The Details tab has multiple sub-sections called *accordions* that can be expanded to reveal more information. You can have multiple accordions expanded at the same time.

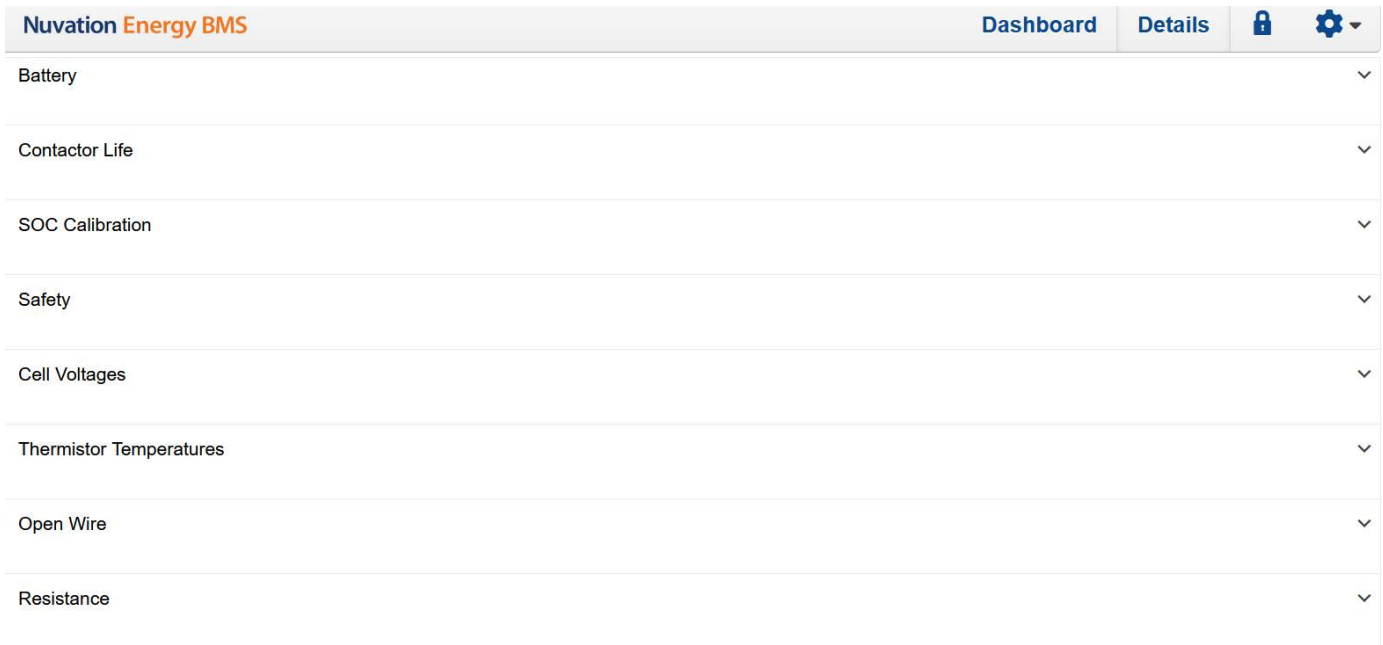

Figure 63. Nuvation Energy BMS Operator Interface Details tab screenshot



Figure 64. Operator Interface Support Button



The SUPPORT button can be used to direct the operator to the Nuvation Energy website to contact Support.

5.3.2.1. Battery

The Battery accordion contains values on the overall battery stack and the maximum charge current limit, the maximum discharge current limit, and the number of cells balancing in the battery stack. This information is identical to the values shown in the radial gauges, the bar gauges and the

Information Table on the Dashboard.

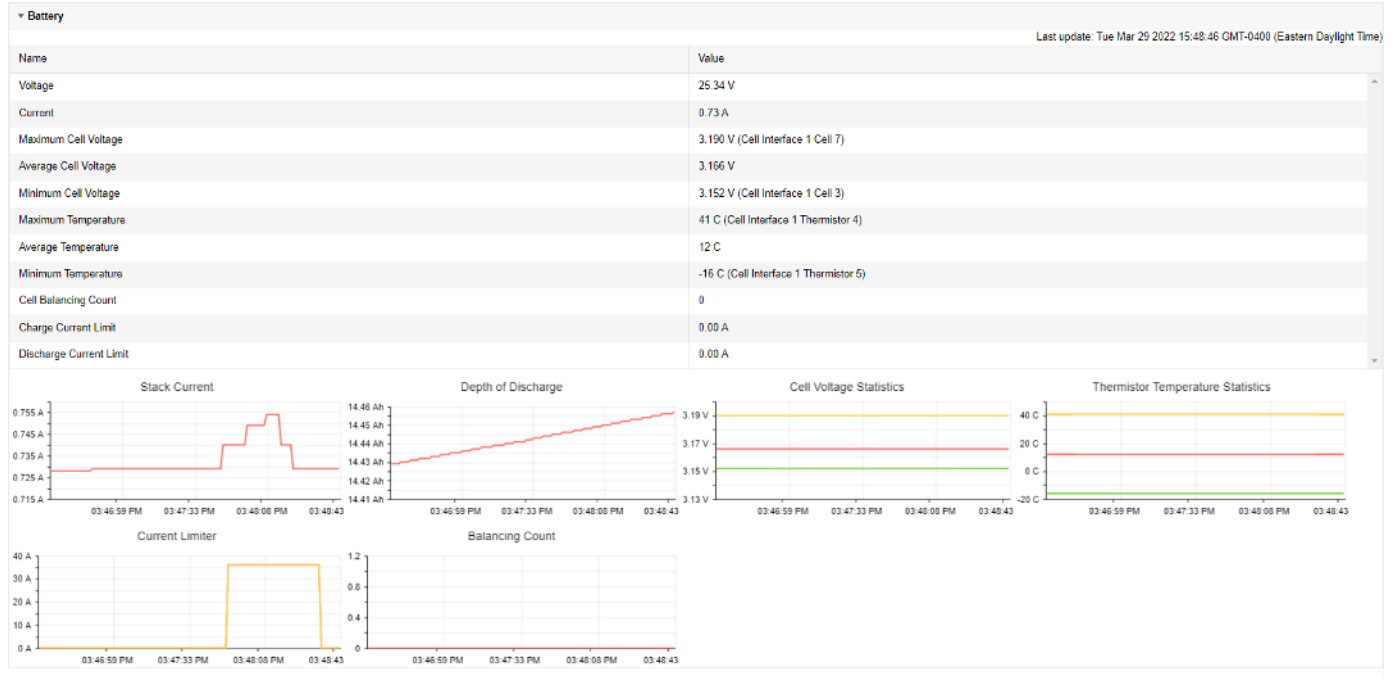

Figure 65. Battery accordion in Details Tab

5.3.2.2. Contactor Life

The Contactor Life accordion contains values that track the life of contactors. See Contactor Life Tracking for further information.

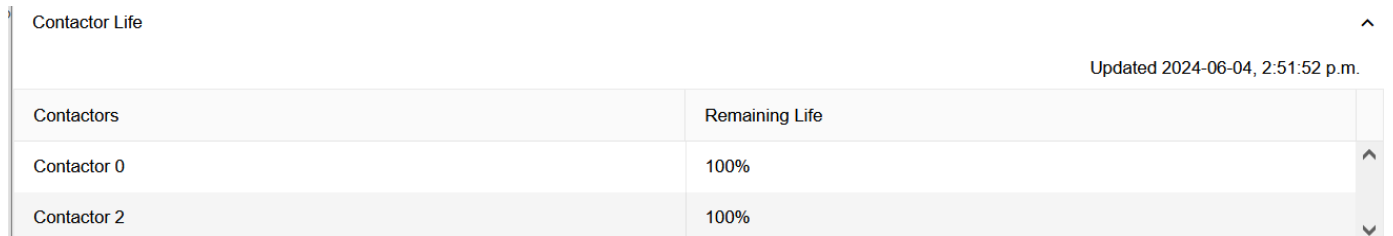

Figure 66. Contactor Life accordion in Details Tab

5.3.2.3. SoC Calibration

The State of Charge Calibration accordion allows for calibration of SoC and reset of the measured capacity estimate. This accordion is only visible if the OCV is enabled (`stack_soc.ocv_enabled`). Both of these operations are only enabled when the battery is operational (not in service lockout) but disconnected (`stack_control.actual_state == 0`).

▼ **SOC Calibration**

Last update: Fri Mar 25 2022 16:27:06 GMT-0400 (Eastern Daylight Time)

Battery Charge		Battery Capacity	
State of Charge	67 %	Measured Capacity	0.000 Ah
Depth of Discharge	0.150 Ah	Nameplate Capacity	1.500 Ah
<input type="button" value="Calibrate"/>		<input type="button" value="Reset"/>	
SOC is calibrated from cell voltages using the open-circuit voltage curve. Battery contactors must be disconnected to calibrate.		Capacity is reset to stack nameplate rating while accounting for cell SOC imbalance. Battery contactors must be disconnected to reset.	

Figure 67. SoC Calibration accordion in Details Tab

Charge Calibration

SoC charge calibration resets the SoC based on the open-circuit voltage curve. More specifically, it uses the measured voltage in the cell and the OCV curve to calculate a cell level SoC estimate. The SoC estimates are aggregated to determine the stack level SoC that is seen on the dashboard. Since the SoC calibration uses the OCV, the curve needs to be enabled.

A user can reset the SoC only if the stack is disconnected. For chemistries like LFP, it is also beneficial to wait 1 hour after disconnection before resetting the SoC. This will allow the battery to relax and reach equilibrium before a reset calculation is conducted. Although it is recommended to wait 1 hour, the period is not enforced on the Operator Interface.

The SoC reset is used to provide a rough initial estimate of SoC before a calibration can occur. This is usually when the BMS is initially connected and setup up. It should not be used as a replacement for SoC calibration, which can be done by charging the battery to FULL.

Capacity Reset

Capacity calibration resets the SoC to the nominal capacity. Note that if the stack is imbalanced, it will update the nominal capacity to account for this imbalance. This is done by calculating the SoC for each cell.

The recommendations for SoC calibration described above can be followed here as well for determining when to do a capacity reset.

The user should reset the capacity if the measured capacity value is significantly different from the nominal capacity and the battery degradation is known. Once again, the reset provides a rough capacity estimate. The ideal approach for determining measured capacity is to conduct a charge to FULL and a discharge to EMPTY calibration cycle.

5.3.2.4. Safety

The Safety accordion contains a comprehensive list of all possible Nuvation Energy BMS faults,

warnings and user triggers as well as the overall status of the battery stack. An active fault is shown as Tripped. An active warning or user trigger is shown as Triggered. A fault, warning or user trigger that has not completed its Self Check is shown as Checking. In normal operation, all user triggers, warnings and faults should be Clear.

▼ Safety Last update: Fri Mar 25 2022 17:25:44 GMT-0400 (Eastern Daylight Time)

Name	State	Trigger
Stack Under Voltage Fault	Clear	stack_fault_voltage_under
Stack Over Voltage Fault	Clear	stack_fault_voltage_over
Stack Low Voltage Fault	Clear	stack_fault_voltage_lo
Stack High Voltage Fault	Clear	stack_fault_voltage_hi
Cell Under Voltage Fault	Clear	stack_fault_cell_under
Cell Over Voltage Fault	Clear	stack_fault_cell_over
Cell Low Voltage Fault	Clear	stack_fault_cell_lo
Cell High Voltage Fault	Clear	stack_fault_cell_hi
Discharge Under Temperature Fault	Clear	stack_fault_discharge_therm_under
Discharge Over Temperature Fault	Clear	stack_fault_discharge_therm_over

Figure 68. Safety accordion in Details Tab

Clicking on the Clear Faults and Warnings button at the bottom of this accordion will clear any faults and warnings that are not self-clearing. The Clear button on the Dashboard can also be used.

Stack Under Voltage Lockout	Clear	stack_uvlo_stack_voltage
Cell Under Voltage Lockout	Clear	stack_uvlo_cell_voltage
Discharge High Current User	Clear	stack_trig_discharge_current_hi
Charge High Current User	Clear	stack_trig_charge_current_hi
Discharge Low Temperature User	Clear	stack_trig_discharge_therm_lo
Discharge High Temperature User	Clear	stack_trig_discharge_therm_hi
Charge Low Temperature User	Clear	stack_trig_charge_therm_lo
Charge High Temperature User	Clear	stack_trig_charge_therm_hi
Stack Low Voltage User	Clear	stack_trig_voltage_lo
Stack High Voltage User	Clear	stack_trig_voltage_hi
Cell Low Voltage User	Clear	stack_trig_cell_lo
Cell High Voltage User	Clear	stack_trig_cell_hi
Stack Controller Configuration Consistency Check Fault	Clear	sc_fault_config

Clear Faults and Warnings Generate Report

Figure 69. Bottom of Safety accordion in Details Tab

Clicking on the Generate Report button at the bottom of this accordion will generate a safety report JSON file with a list of the Nuvation Energy BMS faults and warnings and their current state as well as the current firmware versions.

5.3.2.5. Cell Voltages

The Cell Voltages accordion lists voltage measurements for all Cells configured in the Configuration file. Cells that are not configured are displayed as a - (hyphen). Voltages in red indicate measurements which have triggered a Nuvation Energy BMS fault. Voltages that are highlighted in yellow are open wires. There is no differentiation between cells that are in the normal operating voltage range and cells that have triggered a Nuvation Energy BMS warning. There is also no indication of which particular cells are currently being balanced by the BMS.



	Cell 1	Cell 2	Cell 3	Cell 4	Cell 5	Cell 6	Cell 7	Cell 8	Cell 9	Cell 10	Cell 11	Cell 12	Cell 13	Cell 14	Cell 15	Cell 16
Cl 1	3.333 V	3.333 V	3.333 V	3.333 V	3.333 V	3.333 V	3.333 V	3.333 V	3.333 V	3.333 V	3.333 V	3.333 V	-	-	-	-
Cl 2	3.333 V	3.333 V	3.333 V	3.333 V	3.333 V	3.333 V	3.333 V	3.333 V	3.333 V	3.333 V	3.333 V	3.333 V	-	-	-	-
Cl 3	3.333 V	3.333 V	3.333 V	3.333 V	3.333 V	3.333 V	3.333 V	3.333 V	3.333 V	3.333 V	3.333 V	3.333 V	-	-	-	-
Cl 4	3.333 V	3.333 V	3.333 V	3.333 V	3.333 V	3.333 V	3.333 V	3.333 V	3.333 V	3.333 V	3.333 V	3.333 V	-	-	-	-
Cl 5	3.333 V	3.333 V	3.333 V	3.333 V	3.333 V	3.333 V	3.333 V	3.333 V	3.333 V	3.333 V	3.333 V	3.333 V	-	-	-	-
Cl 6	3.333 V	3.333 V	3.333 V	3.333 V	3.333 V	3.333 V	3.333 V	3.333 V	3.333 V	3.333 V	3.333 V	3.333 V	-	-	-	-
Cl 7	3.333 V	3.333 V	3.333 V	3.333 V	3.333 V	3.333 V	3.333 V	3.333 V	3.333 V	3.333 V	3.333 V	3.333 V	-	-	-	-
Cl 8	3.333 V	3.333 V	3.333 V	3.333 V	3.333 V	3.333 V	3.333 V	3.333 V	3.333 V	3.333 V	3.333 V	3.333 V	-	-	-	-

Figure 70. Cell Voltages accordion in Details Tab

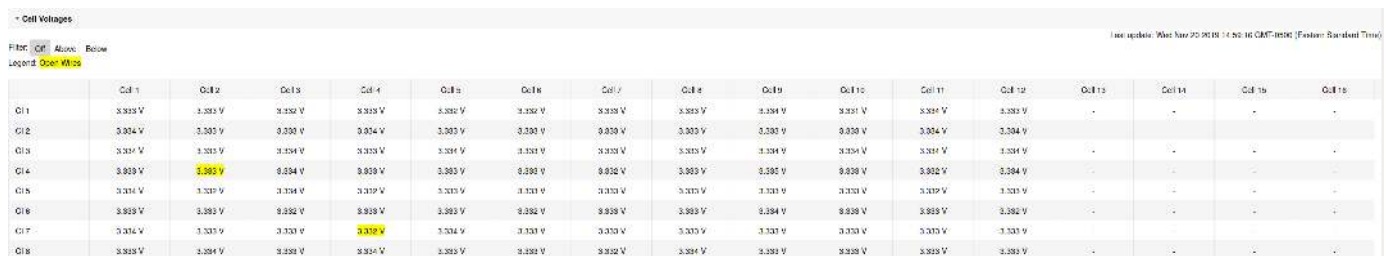

	Cell 1	Cell 2	Cell 3	Cell 4	Cell 5	Cell 6	Cell 7	Cell 8	Cell 9	Cell 10	Cell 11	Cell 12	Cell 13	Cell 14	Cell 15	Cell 16
Cl 1	3.333 V	3.333 V	3.332 V	3.333 V	3.332 V	3.332 V	3.333 V	3.333 V	3.334 V	3.331 V	3.331 V	3.332 V	-	-	-	-
Cl 2	3.334 V	3.333 V	3.330 V	3.334 V	3.333 V	3.331 V	3.333 V	3.333 V	3.333 V	3.330 V	3.334 V	3.334 V	-	-	-	-
Cl 3	3.333 V	3.333 V	3.334 V	3.333 V	3.334 V	3.333 V	3.333 V	3.333 V	3.334 V	3.334 V	3.331 V	3.331 V	-	-	-	-
Cl 4	3.333 V	3.385 V	3.334 V	3.333 V	3.333 V	3.332 V	3.332 V	3.333 V	3.332 V	3.333 V	3.332 V	3.332 V	-	-	-	-
Cl 5	3.334 V	3.333 V	3.334 V	3.333 V	3.333 V	3.331 V	3.333 V	3.333 V	3.333 V	3.333 V	3.333 V	3.333 V	-	-	-	-
Cl 6	3.333 V	3.333 V	3.332 V	3.333 V	3.333 V	3.332 V	3.333 V	3.333 V	3.334 V	3.333 V	3.333 V	3.332 V	-	-	-	-
Cl 7	3.334 V	3.333 V	3.333 V	3.332 V	3.334 V	3.333 V	3.333 V	3.333 V	3.333 V	3.333 V	3.333 V	3.333 V	-	-	-	-
Cl 8	3.333 V	3.334 V	3.333 V	3.334 V	3.332 V	3.332 V	3.332 V	3.331 V	3.331 V	3.333 V	3.333 V	3.333 V	-	-	-	-

Figure 71. Cell Voltages with open wires accordion in Details Tab

Filtering

You can filter the display to highlight cells with voltages above or below a value you specify. The values that match the criteria will be bolded and all other values will be faded.



	Cell 1	Cell 2	Cell 3	Cell 4	Cell 5	Cell 6	Cell 7	Cell 8
Cl 1	3.333 V	3.333 V	3.333 V	3.333 V	3.333 V	3.333 V	3.333 V	3.333 V

5.3.2.6. Thermistor Temperatures

The Thermistor Temperatures accordion lists temperature measurements for all Thermistors configured in the Configuration file. Thermistors that are not configured are displayed as a dash. Temperatures in red indicate measurements which have triggered a Nuvation Energy BMS fault. There is no differentiation between thermistors that are in the normal operating temperature range and thermistors that have triggered a Nuvation Energy BMS warning.

▼ Thermistor Temperatures Last update: Fri Nov 29 2019 12:50:06 GMT-0500 (Eastern Standard Time)

Filter:

	Index 1	Index 2	Index 3	Index 4	Index 5	Index 6	Index 7	Index 8
CI 1	27 °C	27 °C	27 °C	26 °C	27 °C	27 °C	-	-
CI 2	27 °C	27 °C	28 °C	27 °C	28 °C	27 °C	-	-
CI 3	26 °C	26 °C	27 °C	27 °C	27 °C	27 °C	-	-
CI 4	27 °C	27 °C	27 °C	27 °C	27 °C	27 °C	-	-
CI 5	28 °C	27 °C	27 °C	27 °C	27 °C	27 °C	-	-
CI 6	27 °C	27 °C	27 °C	28 °C	27 °C	27 °C	-	-
CI 7	26 °C	26 °C	26 °C	27 °C	27 °C	27 °C	-	-
CI 8	27 °C	27 °C	27 °C	28 °C	27 °C	27 °C	-	-

Figure 72. Thermistor accordion in Details Tab

Filtering

You can filter the display to highlight cells with temperatures above or below a value you specify. The values that match the criteria will be bolded and all other values will be faded.



5.3.2.7. Open Wire

The Open Wire accordion lists open wire diagnostics for all Cells configured in the Configuration file. Cells that are not configured are displayed as a - (hyphen). Diagnostic data that is highlighted in yellow indicates an open wire.

▼ Open Wire

Press button to start retrieving the ratios.

Figure 73. Open Wire accordion in Details Tab

To trigger diagnostics on all cells, click the "Acquire Open Wire Ratios" button. Once clicked, the open wire scanning process begins.

▼ Open Wire

Starting to scan...
Elapsed Time: 4s

Figure 74. Open Wire acquiring accordion in Details Tab

Once the open wire scanning has completed and all diagnostics data is collected it is displayed in a tabular format with open wires highlighted in yellow.

Open Wire

Acquire Open Wire Ratios
Success getting open wire ratios

Last update: Thu Nov 21 2019 10:57:57 GMT-0500 (Eastern Standard Time)

Filter: Off Above Below

Legend: 0.0 0.97

	Cell 1	Cell 2	Cell 3	Cell 4	Cell 5	Cell 6	Cell 7	Cell 8	Cell 9	Cell 10	Cell 11	Cell 12	Cell 13	Cell 14	Cell 15	Cell 16
Cl1	0.820	0.821	0.822	0.822	0.919	0.919	0.821	0.820	0.820	0.821	0.816	0.820				
Cl2	0.800	0.800	0.804	0.804	0.800	0.800	0.800	0.800	0.804	0.800	0.800	0.801				
Cl3	0.920	0.920	0.922	0.924	0.924	0.923	0.923	0.924	0.925	0.924	0.922	0.920				
Cl4	0.802	0.803	0.821	0.824	0.824	0.823	0.823	0.823	0.822	0.820	0.824	0.825				
Cl5	0.920	0.922	0.921	0.921	0.922	0.922	0.920	0.920	0.922	0.921	0.920	0.920				
Cl6	0.905	0.905	0.908	0.908	0.909	0.909	0.909	0.908	0.908	0.908	0.909	0.907				
Cl7	0.910	0.910	0.912	0.912	0.910	0.910	0.910	0.912	0.912	0.912	0.912	0.910				
Cl8	0.910	0.911	0.912	0.914	0.915	0.915	0.914	0.910	0.912	0.916	0.914	0.914				

Figure 75. Open Wire diagnostics accordion in Details Tab

The diagnostic values displayed are ratios of Voltage. Values very close to one (> 0.97) indicate a short condition. Values approaching zero (0.0 to 0.4) indicate an open wire connection.

Filtering

Use the filter to highlight ratios of Voltage that are above or below the specified value. The values that match the criteria will be bolded and all other values will be faded.

Filter: Off Above Below 0.9

	Cell 1	Cell 2	Cell 3	Cell 4	Cell 5	Cell 6	Cell 7	Cell 8
Cl1	0.900	0.920	0.800	0.800	0.920	0.900	0.800	0.800

5.3.2.8. Resistance

Resistance accordion in Details Tab

The Resistance accordion contains cell resistance estimate values of every installed cell. This accordion is only visible if the cell model estimator is enabled (stack_cell_model_estimator.enabled). See Cell Resistance Estimation for further information.

Filtering is available for resistance values. Use the filter to highlight resistance values that are above or below the specified value. The values that match the criteria will be bolded and all other values will be faded.

Resistance ^

Updated 2024-05-30, 10:17:30 a.m.

Filter:

	Cell 1	Cell 2	Cell 3	Cell 4	Cell 5	Cell 6	Cell 7	Cell 8	Cell 9	Cell 10	Cell 11	Cell 12	
Cl 1	0.300 mΩ	0.300 mΩ	0.300 mΩ	0.300 mΩ	0.300 mΩ	0.300 mΩ	0.300 mΩ	0.300 mΩ	0.300 mΩ	0.300 mΩ	0.300 mΩ	0.300 mΩ	^
Cl 2	-	-	-	-	0.300 mΩ	0.300 mΩ	0.300 mΩ	0.300 mΩ	0.300 mΩ	0.300 mΩ	0.300 mΩ	0.300 mΩ	
Cl 3	0.300 mΩ	0.300 mΩ	0.300 mΩ	0.300 mΩ	-	-	-	-	0.300 mΩ	0.300 mΩ	0.300 mΩ	0.300 mΩ	
Cl 4	0.300 mΩ	0.300 mΩ	0.300 mΩ	0.300 mΩ	0.300 mΩ	0.300 mΩ	0.300 mΩ	0.300 mΩ	-	-	-	-	
Cl 5	0.300 mΩ	0.300 mΩ	0.300 mΩ	0.300 mΩ	0.300 mΩ	0.300 mΩ	0.300 mΩ	0.300 mΩ	0.300 mΩ	0.300 mΩ	0.300 mΩ	0.300 mΩ	
Cl 6	-	-	-	-	0.300 mΩ	0.300 mΩ	0.300 mΩ	0.300 mΩ	0.300 mΩ	0.300 mΩ	0.300 mΩ	0.300 mΩ	
Cl 7	0.300 mΩ	0.300 mΩ	0.300 mΩ	0.300 mΩ	-	-	-	-	-	-	-	-	▼

Figure 76. Resistance accordion in Details Tab

5.3.3. The Menu Options

The menu to the right of the Operator Interface provides access to tools and advanced options. Some of these options may be locked to prevent accidental changes.

The following options are available:

- Registers
- Service
- Connection
- Unlock
- About

5.3.3.1. Registers

This menu option navigates to the Register Browser. This screen allows you to read and write to registers.

When the Operator Interface is locked, the Register Browser is in a view-only mode, restricting the editing of registers.

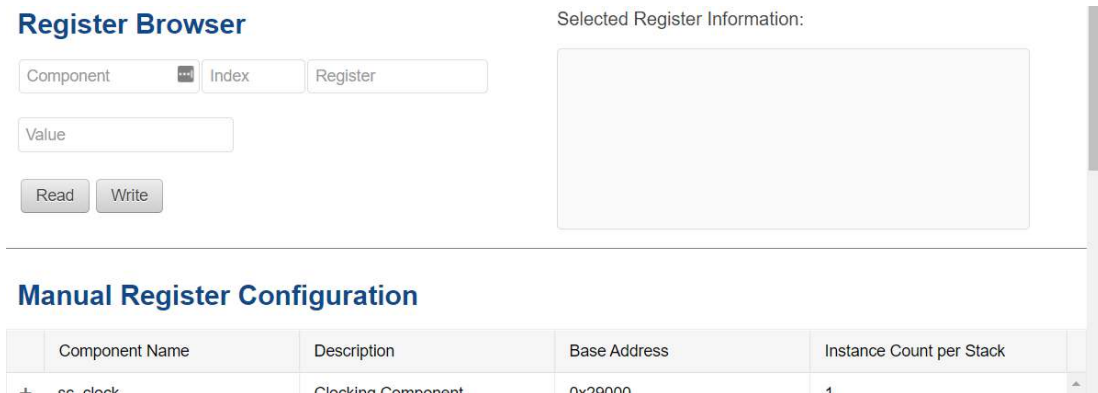

Figure 77. Register Browser

5.3.3.2. Service

This screen allows you to enter and exit Service Lockout in-order to perform an upgrade or configuration file import.

Importing a Configuration File



This is a restricted option requiring the Operator Interface to be unlocked to access this option.

This menu option allows you to import a configuration file.



The G5 High-Voltage BMS ships with a configuration file specific for its end application. Serious problems might occur if the configuration settings are incorrectly modified. If you need assistance with modifying the configuration file, please contact support@nuvationenergy.com.

Exporting a Configuration File



Nuvation Energy BMS does not preserve the originally imported configuration file with comments and formatting. The export feature will export a configuration file with an alphabetical listing of all registers and their set values.

To export your configuration file:

1. From the menu, select Service
2. Click Export Configuration

Upgrade



This is restricted option requiring the Operator Interface to be unlocked to access this option.



The firmware upgrade will erase the configuration file on your Nuvation Energy BMS. Please remember to export and save your current configuration file to save your current configuration file for future reference.



Please contact support@nuvationenergy.com before attempting a firmware upgrade. The current configuration file may not be compatible with different firmware version. Without a valid configuration file, the G5 Stack Switchgear will be rendered non-functional.

Updating a Label

A label is the string displayed on the top banner of the Operator Interface. An owner can configure a name for each stack using the label. When the Operator Interface connects to a stack the operator knows immediately what stack they are connected to.



To update a label:

1. From the menu, select Service
2. Click Edit under the label section

Label

The label is used to identify which BMS you are connected to.

Edit **Apply**

3. Enter a suitable name for the stack

4. Click Apply



The Operator Interface automatically saves the label in persistent storage when applied.



A label does not handle spaces. Use hyphens or underscores to delineate words.



Editing an IP Address

To edit an IP address:

1. From the menu, select Service
2. Click Edit under the ethernet section

Ethernet

The local IP network configuration used by this BMS.

IP Address 0.0.0.0	Netmask 0.0.0.0	Gateway 0.0.0.0
-----------------------	--------------------	--------------------

Edit **Apply**

3. Enter the IP address of your choice

4. Click Apply



The updated IP is saved and in immediate use after the Apply action. Any prior connections via Modbus TCP would have to be reconnected using the updated IP.



Applying changes will disconnect the battery and restart the BMS.

5.3.3.3. Connection

The connection page allows you to change the IP address and timeout of the Nuvation Energy BMS that you are trying to access.

If you are connecting to a Nuvation Energy BMS that does not use the default IP address (192.168.1.21), you will need to change the connection settings in the Operator Interface to match the BMS.



In scenarios where there are multiple BMS systems, it is possible to direct multiple instances of the Operator Interface at the different BMS IP addresses.

5.3.3.4. Locking and Unlocking

The Operator Interface can be locked to prevent accidental or unintentional changes that could have serious impacts on the system. To further secure the system, a password can be set to ensure only authorized individuals can access these critical sections of the Operator Interface



The G5 High-Voltage BMS ships from the factory with password protection on the Operator Interface. Please contact support@nuvationenergy.com for the factory password and documentation for advanced modifications of the G5 High-Voltage BMS.

When the Operator Interface is unlocked, the lock indicator will be replaced with an unlocked indicator.



Figure 78. Operator Interface Locked indicator



Figure 79. Operator Interface Unlocked indicator

Lock the Operator Interface

To lock the Operator Interface, simply click the Unlocked indicator or bring up the settings menu and select Lock.



To prevent accidental changes to your Nuvation Energy BMS, always lock the Operator Interface after making your changes.

It is possible to require a password to unlock the Operator Interface.

Unlock the Operator Interface

To Unlock the Operator Interface, simply click the Locked indicator or bring up the settings menu and select Unlock. If a password has been set, the correct password will need to be entered to complete the unlocking process.

5.3.3.5. About

This screen displays version details for the underlying software for your Nuvation Energy BMS. The name and number of the current software release are displayed at the top of the About screen.

In the screenshot below, the release name is at the top in large blue letters. The version number following the release name has a format of yy.mm with yy representing the year and mm representing the month within that year that this Nuvation Energy BMS package was released.

The version numbers below the release name are the version numbers of the individual software packages running on your Nuvation Energy BMS.

When contacting support, please include the details in your About screen.

About This BMS

Software Version

OI: 1.5.0

Main MCU: 5.8.0:69668113 (Faraday Update 1) (CRC = 10946)
Revision ID = 3735928559

Main MCU BL: 5.7.0

AFE MCU: 0.11.0 (CRC = 5865)

SSG

Serial number: [REDACTED]

Manufacturing: NUVG5-SSG-1500-300-5

SSB

Serial number: [REDACTED]

Manufacturing: ASY-BMSCN21-0502

Factory Lockdown

SC Factory Persist: CRC 39966

Figure 80. Sample About Screen

5.3.4. The Status Banner

The banner at the top of the screen is used to indicate high level changes in system status. During typical operation nothing is displayed and this indicates the Operator Interface is communicating with the BMS and the BMS is fully operational with no major diagnostics problems.

5.3.4.1. Service Lockout Indication

When the system is either entering or is in service lockout, a banner is displayed indicating this to the user.

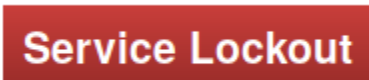

Figure 81. Operator Interface Service Lockout indicator



Figure 82. Operator Interface Entering Service Lockout indicator

5.3.4.2. Self Check Indication

When the system is either exiting service lockout or has just booted, the system will execute a Self Check to verify a safe operation. A banner is displayed indicating the Self Check execution to the user.



Figure 83. Operator Interface Self Check indicator

5.3.4.3. Communication Loss

When the Operator Interface can no longer communicate with the Battery Management System, a communication lost banner is displayed at the top of the display. It will provide the amount of time since disconnected and updates each second.



Figure 84. Operator Interface Communication lost indicator

5.3.5. Understanding the Service Lockout and Self Check

Service Lockout allows you to put your Nuvation Energy BMS into a Lockout state while you perform maintenance on your energy storage installation such as loading new configurations, or upgrading the firmware.

If you are making physical wiring changes, you should enter Service Lockout before powering down Nuvation Energy BMS.

When in Service Lockout, Nuvation Energy BMS will set all faults and warnings as tripped.

A Self Check is a self-test that is executed when:

1. Exiting Service Lockout
2. When booting the Battery Management System

A Self Check is a verification to make sure that the configured Battery Management System is ready for operation. A Battery Management System remains in Self Check until the issues preventing a successful Self Check are corrected. Refer to [Section 5.3.5.3, "Self Check"](#) for further details about the Self Check.



The status for the Service Lockout and Self Check are displayed in the status banner of the Operator Interface as indicated in [Section 5.3.4, "The Status Banner"](#)

5.3.5.1. Entering Service Lockout

1. Unlock the Operator Interface by clicking the Lock indicator and enter the password if prompted.
2. From the menu, select Service to bring up the Service page

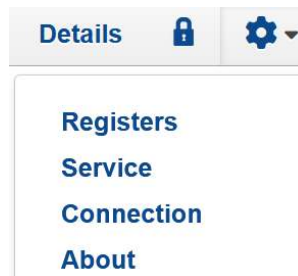

3. Click Enter Service Lockout to enter Service Lockout

 **Service Lockout**

Enter Service Lockout
Exit Service Lockout

Warning: Service Lockout will disconnect the battery and prevent operation.



Entering Service Lockout will open all contactors and GPOs and halt all cell voltage/temperature and stack voltage/current data acquisition.



When in Service Lockout, you will not be able to access the Operator Interface dashboard.

Shutdown Timer for G5 High-Voltage BMS

To protect your batteries, the G5 High-Voltage BMS automatically shuts down after an hour of being in Service Lockout.

If the Enable input is asserted, ([Enable Input](#)), this built-in protection will be disabled and the G5 High-Voltage BMS will remain powered up after 1 hour has expired. Note, the G5 High-Voltage BMS will apply a small load on the cells even in Service Lockout so disabling the automatic shutdown must be done with care as it is possible to over-discharge the cells if left in this state for a significant duration.



If UVLO is disabled or not configured properly (refer to [Section 4.8.4, "UVLO Enable Config Switch Input"](#)), the G5 High-Voltage BMS will remain powered on after this period has expired.

5.3.5.2. Exiting Service Lockout

1. Unlock the Operator Interface by clicking the Locked indicator and enter the password if prompted.
2. From the menu, select Service to bring up the Service page

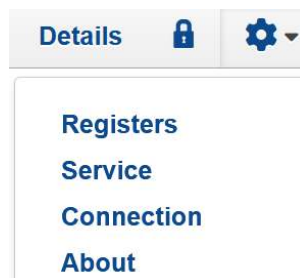

3. Exit the Service Lockout by clicking Exit Service Lockout



Exiting Service Lockout may close contactors

4. A Self Check will be initiated and its banner will be displayed on the Operator Interface. Refer to [Section 5.3.4.2, "Self Check Indication"](#) for banner details.

5.3.5.3. Self Check

The Self Check verifies that all configured data inputs for the faults and warnings of the Battery Management System are being received. The Battery Management System will remain in Self Check until all these data inputs are received. The Self Check is executed continuously unless the Battery Management System is returned back to Service Lockout. If the issue(s) that were preventing a successful Self Check are corrected, the Battery Management System will enter operation. You will be able to access the dashboard controls once Nuvation Energy BMS has successfully completed the Self Check.

5.3.5.4. Self Check Troubleshooting

If Nuvation Energy BMS fails its Self Check, you will receive an error notification. The reason for the failure is that some form of input to the Battery Management System was not received. This means that the Battery Management System was expecting some measurement (e.g. cell voltage, current) but it never was received by the software. Because of this lack of data, the Battery Management System should not be operated and the issue(s) needs to be resolved. There are two main causes for a lack of Self Check failures:

- Misconfiguration: The current configuration does not match the Battery Management System deployment.
- Incomplete setup: There is an issue in the setup of the Battery Management System (e.g. cables are missing or faulty)

You can identify the parts of the Battery Management System that have not completed their Self Check by referring to the Details > Safety accordion section. The faults/warnings that are currently failing Self Check are indicated by the red text "Checking" on the right side of the display.

Refer to [Section 8.1, "Faults and Self Check Failures"](#) for details on how to address the Self Check failures.

If you just imported a configuration file, re-import a known-good configuration file.



If the failures persist, please submit a support ticket with as much detail as possible to support@nuvationenergy.com.

5.4. Communication Protocols

5.4.1. Modbus Protocol Support

G5 High-Voltage BMS implements the SunSpec Energy Storage Models (Draft 3) as the top-level Modbus interface to the product. Specifically the G5 High-Voltage BMS implements the 800 series Models.

5.4.1.1. Modbus TCP

This protocol is used for communications over TCP/IP networks. A single Modbus TCP connection is supported over port 502 for read and write access. All register data is transmitted as big-endian (most significant byte first).

The G5 High-Voltage BMS has separate regions of Modbus points to access the following data:

1. SunSpec Energy Storage Models as detailed in [Section 5.4.1.2, "Implemented SunSpec Energy Storage Models"](#)
2. Configurable Modbus points to access specific Battery Management System registers as detailed in [Section 5.4.1.5, "Configurable Modbus"](#).

The Battery Management System uses the Modbus *unit identifier* from the Modbus TCP protocol to select the different regions of data. The start address and unit identifier of each region of Modbus points are shown in the following table. All data is accessed as holding registers in each selected region.

Table 50. Data Access Based on Modbus Unit Identifier

Unit Identifier	Data Accessed	Start Address
0	No Modbus points	N/A
1	SunSpec (Draft 3) (e.g. Common, S 801, S 802, S 803)	40000
2	Configurable Modbus data points	0
3-255	No Modbus points	N/A

5.4.1.2. Implemented SunSpec Energy Storage Models

The SunSpec Energy Storage Models contain a number of 'Models' that can be implemented by vendors to describe a storage device at various levels of detail.

The Models implemented by Nuvation Energy BMS are described in the sections below. The SunSpec Information Model Reference (*SunSpec-Energy-Storage-Information-Models_Draft_3.xlsx*) is available for download under the G5 High-Voltage BMS section on the Nuvation Energy technical resources page located at <https://www.nuvationenergy.com/technical-resources>.

Common Model

This model primarily contains information to identify the device (e.g. manufacturer, model, serial number) as well as the version of software running on the device. The Modbus address of this model

is 40000. [Table 51, "Common Model Points"](#) describes the points of the Common Model as implemented in the BMS. A full description of the Common Model can be found in the SunSpec specification bundle.

Table 51. Common Model Points

Point Name	Address	Description	Note
SunSpec_ID	40000	Identifies this as a SunSpec Modbus Map	Set to 0x53756e53
ID	40002	Identifies Common Model Block	Set to 0x0001
L	40003	Length of block	Set to 66
Mn	40004	Device Manufacturer	Set to "Nuvation Engineering"
Md	40020	Device Model Number	Contents of BMS registers <code>sc_mfg_info.manufacturing<0-3></code>
Opt	40036	Options	Set to "Fully Loaded"
Vr	40044	Version Information	Contents of the <code>sc_fw_image.build_version</code> and <code>sc_fw_image.build_id</code> BMS registers separated by a colon
SN	40052	Device Serial Number	Contents of BMS registers <code>sc_mfg_info.serialnumber<0-1></code>
DA	40068	Device Address	Set to 0x1234

801 (Energy Storage Base Model)

This model describes an energy storage device at the highest possible level. State-of-Charge and overall alarm and warning states are found here. All mandatory points are implemented. The Modbus address of this model is 40070.

802 (Battery Base Model)

This model describes a battery storage device. At this level, the critical operational information includes the charge and discharge current limits. All mandatory points are implemented. The Modbus address of this model is 40094.

803 (Lithium-Ion Battery Model)

This model describes a lithium-ion battery in detail. Voltage, temperature, and current statistics are available at the pack and stack level within this model. All mandatory and most optional points are implemented. The Modbus address of this model is 40116.

End Model

This model marks the end of the implemented Modbus address space.

5.4.1.3. SunSpec Energy Storage Models Structure and Nomenclature

This section is a clarification of terms used to describe SunSpec Energy Storage Models. It is used to understand the terminology in the spreadsheet presented in the previous section.

Points

All SunSpec Energy Storage Models are a collection of points (i.e. Modbus registers). These points can be one or more Modbus registers in length. By definition, each Modbus register is 16 bits wide. For points that are larger than one Modbus register, partial read accesses are not allowed. A Modbus request to a SunSpec point must read all registers that make up the point. Otherwise, a Modbus read/write error is returned on such an access.

For example, the SunSpec 802 model has the Evt1 point which is of type bitfield32. In this case, the point spans 2 Modbus registers and so a request to read this point must read 2 Modbus registers.

Fixed/Repeating Blocks

SunSpec Energy Storage Models are described as collections of Fixed and Repeating blocks of points. A Fixed block is a set of points that is always defined and never changes in its size. A Repeating block describes a set of related points (i.e. usually for a string of batteries) of which there could be multiple instances of the Repeating blocks. The points within a repeating block are the same but these sets of blocks are concatenated sequentially.

For example in the 803 model, there is a set of repeating blocks that describe data for a particular stack/string of batteries. Accessing the 803 repeating block corresponds to using a stack/string index (0, 1, 2, ...) to access the desired repeating block.

For a single-stack Nuvation Energy BMS there is only one 803 repeating block.

If a stack/string is configured in Nuvation Energy BMS software to be installed, then accessing its 803 repeating block will provide a valid Modbus response.

Repeating blocks are taken into account in the length indicated in the model header.

Unimplemented Points

Any SunSpec point that is not implemented by a vendor will generate an unimplemented response. The response will be a valid Modbus read response but all point data returned will report unimplemented values. The unimplemented values vary by type as listed in the following table.

Table 52. Unimplemented Point Values

Type	Width (bits)	Unimplemented Value (hexadecimal)
signed int	16	0x8000
unsigned int	16	0xFFFF
signed int	32	0x80000000
unsigned int	32	0xFFFFFFFF
enumeration	16	0xFFFF
enumeration	32	0xFFFFFFFF

A write to a writeable SunSpec point that is unimplemented will generate a Modbus write error.

The SunSpec implementation on Nuvation Energy BMS has unimplemented points as follows:

Table 53. Unimplemented SunSpec Points

Model	Point Name	Description
801	Evt	Event status bitfield
801	DisChaRate	Self Discharge Rate
801	MaxRsvPct	Maximum Reserve Percent
801	MinRsvPct	Minimum Reserve Percent
801	ChaSt	Charge Status
801	DerAlarmReset	Alarm Reset (read is unimplemented)
802	CycleCt	Cycle Count
802	WMaxDisChaRte	NamePlate Max Discharge Rate
802	SoH	State of Health (reported in 803 model per string)
802	BatReqPCSSt	PCS State Request
802	BatReqW	Battery Power Request
802	SoH_SF	State of Health Scale Factor
802	BatReqW_SF	Battery Power Request Scale Factor
803	StrEvt2	String Event 2
803	StrConFail	String Connection Fail

Scale Factors

All SunSpec points are integer values (signed or unsigned). To account for different range values beyond the data size (i.e. greater than 65535 for an unsigned 16 bit value) or some fractional value (i.e. 1.1), some SunSpec points have scale factors associated with them. The scale factor is another point within the model which contains a signed integer exponent of base 10 that scales a corresponding point value. For example, a scale factor of 2 would result in multiplying the corresponding point by 100. Likewise a scale factor of -3 would result in a scale factor of 0.001. Refer to the prior SunSpec Energy Storage Models spreadsheet for the relationship between Points and their scale factors. All scale factors are fixed for a Model and do not change in value.

5.4.1.4. Operational Cases for SunSpec Modbus Interface

There are two main operational cases for the control of Nuvation Energy BMS over its SunSpec interface:

1. An external controller (sometimes called "Energy Storage Controller") is used to coordinate power control functions of the BMS in conjunction with some other equipment (such as an inverter). This controller requires periodic and rapid responses of SunSpec point reads as well as some control over the operation of the BMS (such as stack connectivity). If there is a loss of communication between this controller and the BMS, the BMS will disconnect the stack(s) as a safety precaution.
2. An owner/operator of a battery system requires control of the BMS to monitor the activity of the

batteries and track battery usage and its charge/discharge activities. This information can then be used to characterize the usage of the Battery Management System and to validate battery warranties of a vendor.

Read and write Modbus TCP operations can be performed over the standard Modbus port 502 (only a single connection is supported on this port).

The shortest polling periods expected for the SunSpec Energy Storage Models during operation are listed below:

- All fixed model blocks: 100ms
- 801: less than 100ms
- 802: less than 100ms
- 803 Fixed Block: less than 100ms
- 803 Repeating Block(s): less than 100ms (single block)

Depending on BMS system load and size, some requests could take up to 1000ms. The BMS typically samples data at between 250ms to 1000ms depending on configuration, so reading the data faster than this will not improve system behaviour and incurs unnecessary overhead.

These two operational cases will be discussed in detail in the following sections.

External Controller Communicating Over SunSpec Modbus Interface

An external controller typically polls Nuvation Energy BMS battery control points at a rate of 2–4 Hz. This controller reads data points required to manage current flow in the system. The following table summarizes the most important points an external controller may want to read from the BMS.

Table 54. SunSpec Points Read by an External Controller

Model	Block	Point Name	Address	Scale Factor	Purpose
801	Fixed	DERHb	40086	No	BMS Heartbeat counter incremented every second
802	Fixed	Evt1	40101	No	Bit field of all faults/warnings of a the BMS
802	Fixed	Vol	40105	Yes	External DC voltage of the battery system
802	Fixed	MaxBatACha	40106	Yes	Charge current limit calculated by the BMS
802	Fixed	MaxBatADischa	40107	Yes	Discharge current limit calculated by the BMS
803	Fixed	BTotDCCur	40127	Yes	Total DC current of the battery system

A controller may also want to command Nuvation Energy BMS to perform certain actions, such as connecting/disconnecting the battery. The following table provides the different writeable points in the SunSpec interface for different control functions:

Table 55. SunSpec Points Written to by an External Controller

Model	Block	Point Name	Address	Purpose
801	Fixed	ControllerHb	40087	Heartbeat register for external controller
801	Fixed	DERAlarmReset	40088	Clears all latched alarms in the BMS
802	Fixed	BSetOperation	40110	Commands Nuvation Energy BMS to connect/disconnect the battery

When configured, the heartbeat controller can be used to update the watchdog timer of Nuvation Energy BMS on single-stack and multi-stack implementations. If the heartbeat point is not updated within the watchdog timer period, a fault will be generated on the BMS stack and its corresponding contactors will be opened. The value written to the heartbeat point must increase in value and roll over to zero when the 16 bit range limit is reached.

The clearing of alarms of Nuvation Energy BMS is accomplished by writing a value of 1 to the DERAlarmReset point. This point is erroneously identified as read-only in the SunSpec Energy Storage Models spreadsheet referenced earlier. Note that the alarm will not be cleared if the alarm condition is still present.



Only BMS Faults are cleared using this point. BMS Warnings are not cleared.

Commanding the Nuvation Energy BMS stack/string to connect/disconnect is accomplished through the BSetOperation point. This point accepts the enumerated values for these connect/disconnect operations. Additional connection logic (such as separate pre-charge circuitry) is managed automatically by the BMS when it is configured for such an operation.

External Nuvation Energy BMS Monitoring Over SunSpec Interface

An external data logger may want to access a variety of data from the BMS. In general, a data logger will not actively manage Nuvation Energy BMS; normally, it will not initiate actions such as connecting a battery stack to the DC voltage bus or clearing faults. A data logger should connect to one of the read-only Modbus connections (if available) to allow the writable Modbus connection to be available for separate external control functions. The following table contains the SunSpec Energy Storage Models Points exposed by the BMS that could be collected for logging purposes.

Table 56. SunSpec Points Read by External Data Logger

Model	Block	Point Name	Address	Scale Factor	Purpose
801	Fixed	SoC	40081	Yes	BMS State of Charge
801	Fixed	DERHb	40086	No	BMS Heartbeat counter incremented every second
802	Fixed	Evt1	40101	No	Bit field of all faults/warnings of a BMS
802	Fixed	Vol	40105	Yes	External DC voltage of the battery system
802	Fixed	MaxBatACha	40106	Yes	Charge current limit calculated by BMS
802	Fixed	MaxBatADischa	40107	Yes	Discharge current limit calculated by BMS
802	Fixed	BSetOperation	40110	No	BMS requested connection state of all stacks/strings

Model	Block	Point Name	Address	Scale Factor	Purpose
803	Fixed	BConStrCt	40118	No	Number of stacks/strings with contactor closed
803	Fixed	BMaxCellVol	40119	Yes	Maximum cell voltage measured
803	Fixed	BMaxCellVolLoc	40120	No	Module/String location of maximum cell voltage
803	Fixed	BMinCellVol	40121	Yes	Minimum cell voltage measured
803	Fixed	BMinCellVolLoc	40122	No	Module/String location of minimum cell voltage
803	Fixed	BMaxModTmp	40123	Yes	Maximum module temperature
803	Fixed	BMaxModTmpLoc	40124	No	Module/String location for maximum module temperature
803	Fixed	BMinModTmp	40125	Yes	Minimum module temperature
803	Fixed	BMinModTmpLoc	40126	No	Module/String location for minimum module temperature
803	Fixed	BTotDCCur	40127	Yes	Total DC current of the battery system
803	Fixed	BMaxStrCur	40128	Yes	Largest DC current reported by a stack/string
803	Fixed	BMinStrCur	40129	Yes	Smallest DC current reported by a stack/string
803	Repeat	StrSoC	40135 +Index	No	State of charge for a stack/string
803	Repeat	StrSoH	40136 +Index	Yes	State of health for a stack/string
803	Repeat	StrCur	40137 +Index	Yes	Current of a stack/string
803	Repeat	StrMaxCellVol	40138 +Index	Yes	Maximum cell voltage of a stack/string
803	Repeat	StrMinCellVol	40139 +Index	Yes	Minimum cell voltage of a stack/string
803	Repeat	StrCellVolLoc	40140 +Index	No	Location of min/max cell voltages of a stack/string
803	Repeat	StrMaxModTmp	40141 +Index	Yes	Maximum module temperature of a stack/string
803	Repeat	StrMinModTemp	40142 +Index	Yes	Minimum module temperature of a stack/string
803	Repeat	StrModTmpLoc	40143 +Index	No	Location of min/max module temperatures of a stack/string
803	Repeat	StrEvt1	40144 +Index	No	Alarms warnings and status bitfield of a stack/string



The term Index in the Repeating block addresses used in the above table refers to a calculation of $\text{Index} = \text{Stack Index} * \text{Length of Repeating block}$. By definition, the 803 Repeating block is 16 Modbus registers in length.

5.4.1.5. Configurable Modbus

The Modbus communication interface has been augmented with a new range of Modbus points. These points allow the mapping of BMS registers into read/write Modbus operations. The mapping of BMS registers to Modbus is accomplished by two different approaches.

1. Mapping of up to 256 individual BMS registers to a set of Modbus points
2. The bulk mapping of BMS register instances (i.e. cell voltages) into a set of Modbus points. Up to 16 different bulk maps can be configured.

Both Modbus read and write operations are supported for the individual BMS register points. This flexibility allows a greater range of Battery Management System data not expressed in the SunSpec Energy Storage Models to be accessed over Modbus.



The Battery Management System data that is associated with its safe operation can not be written to over Modbus when the Battery Management System has its factory configuration locked.

The access to these configurable Modbus points is controlled by the *unit identifier* used in the Modbus TCP protocol. The *unit identifier* selects between the SunSpec Energy Storage Models and the configurable Modbus points. The *unit identifier* and start address of each region of Modbus points is in [Table 50, “Data Access Based on Modbus Unit Identifier”](#). All data is accessed as holding registers in each region.

The configurable Modbus points are further split into different address regions. There are two different types of address regions.

1. 256 BMS registers accessible through read/write Modbus points
2. 16 sets of read only bulk map Modbus points

The bulk map regions of configurable Modbus points allow mapping of arrays of similar data measurements, such as cell voltages or temperatures, without having to configure each register address.

Table 57. Configurable Modbus Holding Register Addresses

Modbus Region ID	Holding Register Address Range	Configurable Data Accessed
0	0x0000 - 0x03FF	Configurable Modbus points
1	0x0400 - 0x0B7F	Configurable bulk map region 1
2	0x0B80 - 0x12FF	Configurable bulk map region 2
3	0x1300 - 0x1A7F	Configurable bulk map region 3
....
15	0x6D00 - 0x747F	Configurable bulk map region 15
16	0x7480 - 0x7BFF	Configurable bulk map region 16

The Modbus Region ID is used in the following configuration section to identify which regions of the configurable Modbus correspond to the BMS register configuration.

Configuration

The following BMS registers are used to configure the Configurable Modbus points and bulk map points. The *Modbus Region ID* is used from the prior Modbus holding register [table](#) to identify which different Modbus region the configuration applies to.

Table 58. Configurable Modbus Configuration Registers

BMS Register	Description	Modbus Region ID
sc_modbus_map[0:255].address	Specifies the address of the BMS address to access	0
sc_modbus_map[0:255].command	Specifies if the access is read-only (0) or read/write (1) 0 for the corresponding address	0
sc_modbus_bulk_map[0:15].baseaddress	Specifies the base address of set of BMS register instances to access as a bulk map	1 to 16
sc_modbus_bulk_map[0:15].baseenableaddress	Specifies the base address of set of BMS register instances that are used to determine each corresponding bulk instance is installed	1 to 16

The following is an example configuration for the Configurable Modbus. This configuration provides the following output and control:

1. Read registers from entries 0 through 27 in Modbus region ID 0
2. Read/Write registers from 100 through 104 in Modbus region ID 0
3. Read cell voltages from Modbus bulk map region ID 1
4. Read cell temperatures from Modbus bulk map region ID 2
5. Read cell balancing counters from Modbus bulk map region ID 3

Example configuration for Configurable Modbus

```
#
#####
# MODBUS
#####
#
# Individual Read Points
#
sc_modbus_map[0].address = @sc_clock.seconds
sc_modbus_map[1].address = @stack_soc.soc
sc_modbus_map[2].address = @stack_soc.dod
sc_modbus_map[3].address = @stack_power.voltage
sc_modbus_map[4].address = @stack_power.current
sc_modbus_map[5].address = @stack_power.power
sc_modbus_map[6].address = @ssg_bus_power.voltage
sc_modbus_map[7].address = @ssg_bus_power.current
sc_modbus_map[8].address = @ssg_bus_power.power
sc_modbus_map[9].address = @stack_power.energy
sc_modbus_map[10].address = @stack_power.throughput_charge_energy
```

```

sc_modbus_map[11].address = @stack_power.throughput_discharge_energy
sc_modbus_map[12].address = @stack_power.charge
sc_modbus_map[13].address = @stack_power.throughput_charge
sc_modbus_map[14].address = @stack_power.throughput_discharge
sc_modbus_map[15].address = @stack_cell_stat.max
sc_modbus_map[16].address = @stack_cell_stat.min
sc_modbus_map[17].address = @stack_cell_stat.avg
sc_modbus_map[18].address = @stack_therm_stat.max
sc_modbus_map[19].address = @stack_therm_stat.min
sc_modbus_map[20].address = @stack_therm_stat.avg
sc_modbus_map[21].address = @stack_current_limit.charge_current_disable
sc_modbus_map[22].address =
@stack_current_limit.discharge_current_disable
sc_modbus_map[23].address = @stack_current_limit.charge_current_limit
sc_modbus_map[24].address = @stack_current_limit.charge_current_percent
sc_modbus_map[25].address = @stack_current_limit.discharge_current_limit
sc_modbus_map[26].address =
@stack_current_limit.discharge_current_percent
sc_modbus_map[27].address = @stack_control.connection_state
#
# Individual Write Points
#
sc_modbus_map[100].address = @stack_trigger_summary.clear_faults
sc_modbus_map[100].command = 1
sc_modbus_map[101].address = @stack_control.requested_state
sc_modbus_map[101].command = 1
sc_modbus_map[102].address = @sc_controller_heartbeat.value
sc_modbus_map[102].command = 1
sc_modbus_map[103].address = @sc_gpo[0].value
sc_modbus_map[103].command = 1
sc_modbus_map[104].address = @sc_gpo[1].value
sc_modbus_map[104].command = 1
#
# Bulk Modbus report block: cell voltages
#
sc_modbus_bulk_map[0].base_address = @cell.voltage
sc_modbus_bulk_map[0].enabled_address = @cell.installed
#
# Bulk Modbus report block: cell temperatures
#
sc_modbus_bulk_map[1].base_address = @therm.temperature
sc_modbus_bulk_map[1].enabled_address = @therm.installed
#
# Bulk Modbus report block: cell balancing event counters
#
sc_modbus_bulk_map[2].base_address = @cell.balancing_event_count
sc_modbus_bulk_map[2].enabled_address = @cell.installed
#

```

5.4.1.6. Accessing SunSpec Energy Storage Models

SunSpec Energy Storage Models are located contiguously in the Modbus address space starting at a base address of 40000. The Common Model is always located first in this space. The End Model is always last and is used to denote the end of SunSpec Modbus registers. Each model located between the Common Model and the End Model has a numeric identifier as well as a length. A handy tool that can be used to explore the SunSpec Modbus registers for Nuvation Energy BMS is modpoll.exe. It is available for free download at <http://www.modbusdriver.com/modpoll.html>.

Using modpoll.exe, the Common Model can be polled from a using the following command (assuming the device has an IP address of 192.168.1.21)

Polling example with BMS IP address of 192.168.1.21

```
modpoll.exe -m tcp -0 -r 40000 -c 70 192.168.1.21

modpoll 3.4 - FieldTalk(tm) Modbus(R) Master Simulator
Copyright (c) 2002-2013 proconX Pty Ltd
Visit http://www.modbusdriver.com for Modbus libraries and tools.

Protocol configuration: MODBUS/TCP
Slave configuration...: address = 1, start reference = 40000 (PDU), count = 70
Communication.....: 192.168.1.21, port 502, t/o 1.00 s, poll rate 1000 ms
Data type.....: 16-bit register, output (holding) register table

-- Polling slave... (Ctrl-C to stop)
[40000]: 21365
[40001]: 28243
[40002]: 1
[40003]: 66
.
.
.
[40068]: 4660
[40069]: -32768
```

As another example, the complete 802 model for a system with one stack could be polled using the following command:

Example with BMS IP address of 192.168.1.21

```
modpoll.exe -m tcp -0 -r 40094 -c 22 192.168.1.21

modpoll 3.4 - FieldTalk(tm) Modbus(R) Master Simulator
Copyright (c) 2002-2013 proconX Pty Ltd
Visit http://www.modbusdriver.com for Modbus libraries and tools.

Protocol configuration: MODBUS/TCP
Slave configuration...: address = 1, start reference = 40094 (PDU), count = 22
```

```
Communication.....: 192.168.1.21, port 502, t/o 1.00 s, poll rate 1000 ms  
Data type.....: 16-bit register, output (holding) register table
```

```
-- Polling slave... (Ctrl-C to stop)
```

```
[40094]: 802
```

```
[40095]: 20
```

```
.
```

```
.
```

```
.
```

```
[40114]: -2
```

```
[40115]: -32768
```

5.5. Fault/Warning/User Trigger Bitfields

Fault, warning and user defined triggers are aggregated to separate bitfield registers. Likewise there is a bitfield defined to identify the fault/warning/user triggers that are not initialized. This later data can be used to identify the cause(s) of why a BMS does not complete its Self Check.

The following table lists the new bitfield registers.

Table 59. Aggregated Fault/Warning Bitfields

Register	Description
sc_bitfield_fault_triggered	Aggregation of all fault triggers to a bitfield
sc_bitfield_warning_triggered	Aggregation of all warning triggers to a bitfield
sc_bitfield_user_trig_triggered	Aggregation of all user defined triggers to a bitfield

The registers for each bitfield component are defined as follows:

Table 60. Aggregated Bitfield Registers

Register	Description
sc_bitfield_*.bit_count	Number of aggregated bits in the bitfield
sc_bitfield_*.bitfield	Aggregated bitfield data
sc_bitfield_*.initialized	Indication of triggers that have been initialized. A trigger is initialized if the data it monitors has been received at least once. An uninitialized trigger is usually due to either a mis-configuration or a hardware failure that prevents data acquisition. An initialized trigger has passed it corresponding Self Check.

Refer to [Section 8.1, “Faults and Self Check Failures”](#) to assess Self Check failures.

Several *helper* components are defined to identify which trigger each active bit in the bitfields is mapped to. The number of instances of each bitfield helper corresponds to the register value of sc_bitfield_*.bit_count. The helper instance index maps to each bit in the corresponding bitfield for sc_bitfield_*.bitfield. These bitfield associations are constant for the firmware released and will not change due to any configuration change. The helper components available are as follows:

Table 61. Bitfield Helper Components

Component	Description
sc_bitfield_fault_helper	Helper component for the fault bitfield
sc_bitfield_warning_helper	Helper component for the warning bitfield
sc_bitfield_user_trig_helper	Helper component for the user trigger bitfield

Each helper component instance contains one register called:

sc_bitfield_*_helper[*].base_address

These registers define the base address of the fault/warning/user trigger. The base addresses of every component can be read from a corresponding column on the Registers page accessed from the Operator Interface. Each helper instance is mapped 1:1 to the bit in the corresponding bitfield register.



Only a maximum of 63 bits are added to a bitfield. This limit is imposed to avoid the case of 64 triggers being set which could be interpreted as an unimplemented point according to the SunSpec Modbus data models.



The Configurable Modbus feature could be used to read these bitfields over Modbus

5.5.1. Fault Bit Mapping for Faraday Update 1

There are two instances of this bitfield to contain all faults.

Table 62. Fault Bitfield Mapping

Bitfield Component	Instance	Bit	Mapped Component
sc_bitfield_fault_triggered	0	0	ssg_fault_afe_wdt
sc_bitfield_fault_triggered	0	1	ssg_fault_afe_math_overflow
sc_bitfield_fault_triggered	0	2	ssg_fault_afe_config_mismatch
sc_bitfield_fault_triggered	0	3	ssg_fault_afe_reset
sc_bitfield_fault_triggered	0	4	ssg_fault_afe_thermistor_bist
sc_bitfield_fault_triggered	0	5	ssg_fault_currents_mismatch
sc_bitfield_fault_triggered	0	6	ssg_fault_vcoil_voltage_over
sc_bitfield_fault_triggered	0	7	ssg_fault_vcoil_voltage_range
sc_bitfield_fault_triggered	0	8	ssg_fault_vcoil_state_mismatch
sc_bitfield_fault_triggered	0	9	ssg_fault_unexpected_bus_voltage
sc_bitfield_fault_triggered	0	10	ssg_fault_temperature_short_shunt
sc_bitfield_fault_triggered	0	11	sc_fault_controller_wdt
sc_bitfield_fault_triggered	0	12	sc_fault_ci_auth
sc_bitfield_fault_triggered	0	13	stack_fault_precharge_over_current
sc_bitfield_fault_triggered	0	14	stack_fault_precharge_timeout
sc_bitfield_fault_triggered	0	15	stack_fault_contactor_feedback_fail
sc_bitfield_fault_triggered	0	16	sc_fault_ci_internal_temp_over
sc_bitfield_fault_triggered	0	17	stack_fault_cell_hi
sc_bitfield_fault_triggered	0	18	stack_fault_cell_lo
sc_bitfield_fault_triggered	0	19	stack_fault_voltage_hi
sc_bitfield_fault_triggered	0	20	stack_fault_voltage_lo
sc_bitfield_fault_triggered	0	21	stack_fault_discharge_current_hi
sc_bitfield_fault_triggered	0	22	stack_fault_charge_current_hi
sc_bitfield_fault_triggered	0	23	stack_fault_discharge_therm_hi
sc_bitfield_fault_triggered	0	24	stack_fault_discharge_therm_lo
sc_bitfield_fault_triggered	0	25	stack_fault_charge_therm_hi
sc_bitfield_fault_triggered	0	26	stack_fault_charge_therm_lo

Bitfield Component	Instance	Bit	Mapped Component
sc_bitfield_fault_triggered	0	27	ssg_fault_cpu_register_self_test_wdt
sc_bitfield_fault_triggered	0	28	ssg_fault_clock_accuracy_test_wdt
sc_bitfield_fault_triggered	0	29	ssg_fault_afe_aggregate
sc_bitfield_fault_triggered	0	30	ssg_fault_afe_rom_bist_fresh_wdt
sc_bitfield_fault_triggered	0	31	ssg_fault_afe_ram_bist_fresh_wdt
sc_bitfield_fault_triggered	0	32	ssg_fault_afe_cpu_bist_fresh_wdt
sc_bitfield_fault_triggered	0	33	ssg_fault_afe_thermistor_bist_fresh_wdt
sc_bitfield_fault_triggered	0	34	ssg_fault_afe_adc_register_bist
sc_bitfield_fault_triggered	0	35	ssg_fault_afe_spi_cs_bist
sc_bitfield_fault_triggered	0	36	ssg_fault_afe_spi_data_bist
sc_bitfield_fault_triggered	0	37	ssg_fault_power_conn_temp_over
sc_bitfield_fault_triggered	0	38	ssg_fault_therms_wdt
sc_bitfield_fault_triggered	0	39	ssg_fault_power_conn_temp_consistency
sc_bitfield_fault_triggered	0	40	ssg_fault_therm_circuit_fail
sc_bitfield_fault_triggered	0	41	ssg_fault_ambient_therm_fail
sc_bitfield_fault_triggered	0	42	sc_fault_ci
sc_bitfield_fault_triggered	0	43	stack_fault_cell_wdt
sc_bitfield_fault_triggered	0	44	stack_fault_therm_wdt
sc_bitfield_fault_triggered	0	45	stack_fault_ci_wdt
sc_bitfield_fault_triggered	0	46	sc_fault_ci_therm_mux_fail_wdt
sc_bitfield_fault_triggered	0	47	stack_fault_open_wire_wdt
sc_bitfield_fault_triggered	0	48	stack_fault_power_wdt
sc_bitfield_fault_triggered	0	49	sc_fault_ram_test_wdt
sc_bitfield_fault_triggered	0	50	sc_fault_rom_test_wdt
sc_bitfield_fault_triggered	0	51	sc_fault_factory_verify_wdt
sc_bitfield_fault_triggered	0	52	ssg_fault_contactor_life_verify_wdt
sc_bitfield_fault_triggered	0	53	sc_fault_register_link
sc_bitfield_fault_triggered	0	54	sc_fault_clocks
sc_bitfield_fault_triggered	0	55	stack_fault_cell_open_wire
sc_bitfield_fault_triggered	0	56	stack_fault_therm_circuit_fail
sc_bitfield_fault_triggered	0	57	sc_fault_ci_therm_mux_fail
sc_bitfield_fault_triggered	0	58	sc_fault_config_factory
sc_bitfield_fault_triggered	0	59	sc_fault_config_factory_verify
sc_bitfield_fault_triggered	0	60	ssg_fault_config_contactor_life
sc_bitfield_fault_triggered	0	61	ssg_fault_config_contactor_life_verify
sc_bitfield_fault_triggered	0	62	ssg_fault_contactor_life_sanity_check
sc_bitfield_fault_triggered	1	0	stack_fault_voltage_sum

Bitfield Component	Instance	Bit	Mapped Component
sc_bitfield_fault_triggered	1	1	stack_fault_ci_therm_consistency
sc_bitfield_fault_triggered	1	2	ssg_fault_contactor_end_of_life
sc_bitfield_fault_triggered	1	3	ssg_fault_charge_current_over
sc_bitfield_fault_triggered	1	4	ssg_fault_charge_current_hi
sc_bitfield_fault_triggered	1	5	ssg_fault_discharge_current_hi
sc_bitfield_fault_triggered	1	6	ssg_fault_discharge_current_over
sc_bitfield_fault_triggered	1	7	ssg_fault_voltage_over
sc_bitfield_fault_triggered	1	8	stack_fault_cell_over
sc_bitfield_fault_triggered	1	9	stack_fault_cell_under
sc_bitfield_fault_triggered	1	10	stack_fault_discharge_current_over
sc_bitfield_fault_triggered	1	11	stack_fault_charge_current_over
sc_bitfield_fault_triggered	1	12	ssg_fault_bus_discharge_current_over
sc_bitfield_fault_triggered	1	13	ssg_fault_bus_charge_current_over
sc_bitfield_fault_triggered	1	14	stack_fault_voltage_over
sc_bitfield_fault_triggered	1	15	stack_fault_voltage_under
sc_bitfield_fault_triggered	1	16	stack_fault_charge_therm_over
sc_bitfield_fault_triggered	1	17	stack_fault_charge_therm_under
sc_bitfield_fault_triggered	1	18	stack_fault_discharge_therm_over
sc_bitfield_fault_triggered	1	19	stack_fault_discharge_therm_under
sc_bitfield_fault_triggered	1	20	ssg_fault_gpi
sc_bitfield_fault_triggered	1	21	ssg_fault_hysteresis_aggregate
sc_bitfield_fault_triggered	1	22	sc_fault_comm_hysteresis_aggregate
sc_bitfield_fault_triggered	1	23	sc_fault_batt_hysteresis_aggregate
sc_bitfield_fault_triggered	1	24	sc_fault_config
sc_bitfield_fault_triggered	1	25	stack_fault_combined_therm_hi
sc_bitfield_fault_triggered	1	26	stack_fault_combined_therm_lo
sc_bitfield_fault_triggered	1	27	stack_fault_combined_voltage_hi
sc_bitfield_fault_triggered	1	28	stack_fault_combined_voltage_lo

5.5.2. Warning Bit Mapping for Faraday Update 1

There is only one instance of this bitfield.

Table 63. Warning Bitfield Mapping

Bitfield Component	Instance	Bit	Mapped Component
sc_bitfield_warning_triggered	0	0	ssg_warn_fan_control_dc_error
sc_bitfield_warning_triggered	0	1	sc_warn_controller_wdt
sc_bitfield_warning_triggered	0	2	stack_warn_discharge_therm_hi

Bitfield Component	Instance	Bit	Mapped Component
sc_bitfield_warning_triggered	0	3	stack_warn_discharge_therm_lo
sc_bitfield_warning_triggered	0	4	stack_warn_charge_therm_hi
sc_bitfield_warning_triggered	0	5	stack_warn_charge_therm_lo
sc_bitfield_warning_triggered	0	6	stack_warn_cell_hi
sc_bitfield_warning_triggered	0	7	stack_warn_cell_lo
sc_bitfield_warning_triggered	0	8	stack_warn_voltage_hi
sc_bitfield_warning_triggered	0	9	stack_warn_voltage_lo
sc_bitfield_warning_triggered	0	10	stack_warn_discharge_current_hi
sc_bitfield_warning_triggered	0	11	stack_warn_charge_current_hi
sc_bitfield_warning_triggered	0	12	stack_warn_cell_open_wire
sc_bitfield_warning_triggered	0	13	ssg_warn_contactor_end_of_life
sc_bitfield_warning_triggered	0	14	sc_warn_factory_backup_error
sc_bitfield_warning_triggered	0	15	sc_warn_bms_backup_error
sc_bitfield_warning_triggered	0	16	sc_warn_network_backup_error
sc_bitfield_warning_triggered	0	17	ssg_warn_mfg_info
sc_bitfield_warning_triggered	0	18	ssg_warn_gpi
sc_bitfield_warning_triggered	0	19	ssg_warn_hysteresis_aggregate
sc_bitfield_warning_triggered	0	20	sc_warn_hysteresis_aggregate
sc_bitfield_warning_triggered	0	21	stack_warn_therm_hi
sc_bitfield_warning_triggered	0	22	stack_warn_therm_lo
sc_bitfield_warning_triggered	0	23	stack_warn_voltage_combined_hi
sc_bitfield_warning_triggered	0	24	stack_warn_voltage_combined_lo

5.5.3. User Trigger Bit Mapping for Faraday Update 1

There is only one instance of this bitfield.

Table 64. User Trigger Bitfield Mapping

Bitfield Component	Instance	Bit	Mapped Component
sc_bitfield_user_trig_triggered	0	0	ssg_trig_fan_control_charge
sc_bitfield_user_trig_triggered	0	1	ssg_trig_fan_control_discharge
sc_bitfield_user_trig_triggered	0	2	stack_trig_cell_hi
sc_bitfield_user_trig_triggered	0	3	stack_trig_cell_lo
sc_bitfield_user_trig_triggered	0	4	stack_trig_voltage_hi
sc_bitfield_user_trig_triggered	0	5	stack_trig_voltage_lo
sc_bitfield_user_trig_triggered	0	6	stack_trig_discharge_current_hi
sc_bitfield_user_trig_triggered	0	7	stack_trig_charge_current_hi
sc_bitfield_user_trig_triggered	0	8	ssg_trig_fan_control_aggregate

Bitfield Component	Instance	Bit	Mapped Component
sc_bitfield_user_trig_triggered	0	9	stack_trig_uvlo_combined
sc_bitfield_user_trig_triggered	0	10	stack_trig_therm_hi
sc_bitfield_user_trig_triggered	0	11	stack_trig_therm_lo
sc_bitfield_user_trig_triggered	0	12	ssg_trig_afe_stalled
sc_bitfield_user_trig_triggered	0	13	stack_trig_uvlo_cell_voltage
sc_bitfield_user_trig_triggered	0	14	stack_trig_uvlo_stack_voltage
sc_bitfield_user_trig_triggered	0	15	stack_trig_discharge_therm_hi
sc_bitfield_user_trig_triggered	0	16	stack_trig_charge_therm_hi
sc_bitfield_user_trig_triggered	0	17	stack_trig_discharge_therm_lo
sc_bitfield_user_trig_triggered	0	18	stack_trig_charge_therm_lo
sc_bitfield_user_trig_triggered	0	19	ssg_trig_afe_uptime_stalled
sc_bitfield_user_trig_triggered	0	20	ssg_trig_afe_thermistor_bist_update_stalled
sc_bitfield_user_trig_triggered	0	21	ssg_trig_afe_cpu_bist_update_stalled
sc_bitfield_user_trig_triggered	0	22	ssg_trig_afe_ram_bist_update_stalled
sc_bitfield_user_trig_triggered	0	23	ssg_trig_afe_rom_bist_update_stalled
sc_bitfield_user_trig_triggered	0	24	ssg_trig_afe_afe_update_stalled
sc_bitfield_user_trig_triggered	0	25	ssg_trig_afe_temperature_update_stalled

6. Preventative Maintenance

Nuvation Energy G5 High-Voltage BMS contains no serviceable components. All internal components have been designed for long-life assuming the end-application operates the BMS within the stated Operational Limits.

To maintain peak performance of the BMS, the following should be assessed periodically.



The BMS registers listed below can be mapped to a Modbus point using the Configurable Modbus feature. See [Section 5.4.1, "Modbus Protocol Support"](#) for details on how to add these registers to the Modbus map.

6.1. Battery Connections

The bolted connections securing the high-current cables to the G5 Stack Switchgear are monitored for abnormal temperature. The BMS will trip a fault if abnormal temperature is detected. The BMS provides registers that can be monitored by the end-application to observe a change in temperature that may necessitate preventative maintenance to re-torque the bolted connections.

Preventative Action

Periodically check the value of `ssg_power_conn_therms[x].temperature` (or for higher precision check `ssg_power_conn_therms[x].temperature_float`). Replace x with the following to get the required temperature reading:

- 0 for Battery+ terminal temperature reading
- 1 for Battery- terminal temperature reading
- 2 for DC Bus+ terminal temperature reading
- 3 for DC Bus- terminal temperature reading

6.2. Internal Temperature

The internal temperature of the G5 Cell Interface and G5 Stack Switchgear are continuously monitored. A build-up of excess dust or debris blocking the air vents may result in reduced performance of cell balancing and a reduction in the BMS current limits.

The temperature can be monitored by the end-application to observe a change in temperature that may necessitate preventative maintenance to clear the dust / debris to avoid a reduction of performance.

Preventative Action

Periodically check the value of the following registers:

- For G5 Cell Interface temperature: `ci[x].max_ci_temperature``, where x is the index of the G5 Cell Interface starting at 0.
- For G5 Stack Switchgear temperatures:

- Ambient: `ssg_ambient_therm[0].temperature` or `ssg_ambient_therm[0].temperature_float` (for higher precision).
- Fuse: `ssg_fuse_therm[0].temperature` or `ssg_fuse_therm[0].temperature_float` (for higher precision).
- Current Shunt: `ssg_shunt_therm[0].temperature` or `ssg_shunt_therm[0].temperature_float` (for higher precision).
- Internal PCB: `ssg_on_board_therm[x].temperature` or `ssg_on_board_therm[x].temperature_float` (for higher precision) where x is 0 or 1, representing the two onboard thermistors.

6.3. Contactor Life

The remaining life of the high current contactors within the G5 Stack Switchgear are monitored by the BMS. The end-application can monitor the remaining contactor life, and if a reduction in contactor life is observed, the end-application should be reviewed for abnormal use-cases that may be avoided to preserve the remaining life of the contactors. If the contactor life has been consumed, the G5 Stack Switchgear will need to be replaced.

Preventative Action

Periodically check the value of the register `ssg_contactor_life_tracker[x].life_remaining`, where x is 0 or 2, representing the two internal high current contactors.

6.4. Enclosure Condition

The G5 Stack Switchgear enclosure contains metal that may corrode in corrosive environments or corrode if exposed to electrolyte that may have leaked out from the battery cells.

Preventative Action

Periodic visual inspection is recommended to detect corrosion and the source of the corrosion should be addressed to prevent further corrosion of the G5 Stack Switchgear.

6.5. Periodic SoC Recalibration

The accuracy of the estimated State of Charge (SoC) will reduce over time. This measurement is used internally by algorithms and functions within the BMS, as well as used externally by the end-application to make operational decisions. It is recommended to periodically charge to full or discharge to empty to clear out the SoC drift error.

Furthermore, a full charge/discharge cycle is recommended to be completed periodically to update the measured usable capacity of the battery stack. This frequency of charging to full/discharging to empty/performing a full charge-discharge cycle is dependent on the battery cells and the end-application. Generally, a charge to full / discharge to empty event should occur once a week, and a full charge/discharge cycle should occur once every few months.

SoC Recalibration

For periodically recalibrating the SoC, the end-application should charge until the SoC value reports 100% and/or discharge until the SoC value reports 0%. The SoC value will jump to those endpoints or stall at 99% or 1% until the full or empty condition is met.

SoC value can be read from `stack_soc[0].soc` or Modbus point 40081.

The measured usable capacity value will update if the BMS SoC reads 100%, then the system discharges to 0%, while the BMS remains powered on and not in Service Lockout. If the BMS is turned off or enters Service Lockout, the process will need to be restarted.

It is recommended to recharge immediately after recalibrating the measured usable capacity to at least 30% since staying at 0% SoC for a prolonged period of time may reduce the lifetime of the battery.

7. Preparing for Battery Stack Servicing



The order of these steps must be followed in order to maximize the life of the components (the contactors in particular).

7.1. Disconnect Stack

In order to service the stack (including the battery itself), perform the following steps:

1. Allow the battery to come to rest (no current).
 - This may involve sending commands to the PCS.
2. Using the Operator Interface, disconnect the stack by clicking the **Disconnect** button.
 - Refer to the [Section 5.3.1.8, “Nuvation Energy BMS Status”](#) for instructions on connecting/disconnecting a stack.
 - This initiates the disconnection sequence.
 - Wait for the connection state to show **Stack Disconnected**.
3. Using the Operator Interface, transition to the [Service Lockout](#) state.
4. Put the Service Disconnect switch in the **Lock Out** position and insert a lock-out / tag-out.

The battery stack can now be serviced.

7.2. Connect Stack

To bring the stack back into operation, perform the following steps:

1. Remove the lock-out / tag-out and put the Service Disconnect switch in the **Operating** position.
2. Using the Operator Interface, exit the [Service Lockout](#) state.
3. Address any faults if necessary (using the Operator Interface).
 - All faults must be cleared for G5 Stack Switchgear to close contactors.
4. Using the Operator Interface, connect the stack by clicking the **Connect** button.
 - Refer to the [Section 5.3.1.8, “Nuvation Energy BMS Status”](#) for instructions on connecting/disconnecting a stack.
 - This initiates the connection sequence.
 - Wait for the connection state to show **Connected**.

The stack is now connected to the DC bus.



The battery stack terminals are always energized and should be handled as such.

Although the DC bus terminals are disconnected from the battery by the G5 Stack Switchgear unit’s contactors, the DC bus can still be energized by other components on the DC bus (e.g. PCS or other stacks). The DC bus terminals should always be

treated as though they are energized.

A simple voltage check (i.e. across the positive and negative terminals) is not always sufficient, *especially* with grounded battery stacks. It is recommended to also check for voltage between each conductor and ground.

8. Troubleshooting

8.1. Faults and Self Check Failures

During initial setup and usage of a Nuvation Energy BMS, there are two main classes of failures that prevent stack connection:

1. 'Self Check' failures
2. Triggering of faults

When either of these failures occur, an operator of the Operator Interface can open the Details > Safety accordion ([Section 5.3.2.4, "Safety"](#)). That screen presents a list of faults, warnings and user triggers which can have the following states:

Table 65. States for Faults, Warnings and User Triggers

Self Check State	Faults, Warnings, User Triggers	States of Faults, Warnings, User Triggers
Incomplete Self Check	Faults, Warnings, User Triggers	Checking
Completed Self Check	Faults	Clear or Tripped
Completed Self Check	Warnings or User Triggers	Clear or Triggered

All faults, warnings and user triggers that are in a **Checking** state indicate that the Self Check operation is still executing. All fault, warning, and user triggers in this state are not receiving all of their configured input data. The Self Check will continue to execute when there is still at least one fault, warning or user trigger in the **Checking** state. The contactors are not allowed to close while the Self Check is executing.

After the Self Check has completed and when one or more faults are in the **Tripped** state, the Nuvation Energy BMS enters its faulted state and opens all contactors. The contactors can not be commanded to close again until all faults are back in the **Clear** state.

This section will describe the condition the fault monitors and the meaning when that fault has triggered. In addition this section describes how the Self Check failures can occur for the different classes of faults/warnings/user.

In general, all warnings and user triggers have a similar trigger condition as their corresponding fault. The following discussion will focus on the term fault and all descriptions can be applied to the compatible warning or user trigger. Each fault has a descriptive name (e.g. Cell Over Voltage) and a name for the corresponding trigger component (e.g. stack_fault_cell_over). Both names are shown on the details tab of the OI, refer to [Section 5.3.2.4, "Safety"](#) for details.

8.1.1. Cell Voltage Faults

Cell Over Voltage | stack_fault_cell_over

- Fault that is triggered when an installed cell voltage is above the *over* fault threshold.

Cell High Voltage | stack_fault_cell_hi

- Fault that is triggered when an installed cell voltage is above the *high* fault threshold.

Cell Low Voltage | stack_fault_cell_lo

- Fault that is triggered when an installed cell voltage is below the *low* fault threshold.

Cell Under Voltage | stack_fault_cell_under

- Fault that is triggered when an installed cell voltage is below the *under* fault threshold.

8.1.1.1. Self Check Issues



The G5 Stack Switchgear is configured for a specific battery topology based on the details provided to Nuvation Energy during order fulfillment. Failure to use the same number of G5 Cell Interface modules and/or using a different battery topology could result in initialization issue and other undesirable behavior. Please contact support@nuvationenergy.com if there is a change in the system design that would require a G5 Stack Switchgear configuration update.

These faults could fail Self Check through a number of possible conditions such as:

1. Missing or misconfigured G5 Cell Interface modules, preventing the software from completing a full scan of the cell voltage and temperature measurements.
2. Misconfiguration on the number of G5 Cell Interface modules. Refer to the register `sc_linkbus.cicount`.
3. Incorrect G5 Cell Interface configuration. For example if the type of G5 Cell Interface defined in `sc_linkbus.softwareid` is incorrect, it may prevent the cell voltage measurement.
4. Failure in the Link Bus communication. Any interruptions of the bus can prevent the cell voltages from completing a Self Check. Such a failure could happen if:
 - Not all G5 Cell Interface modules are connected.
 - Link Bus cables are connected to the wrong port (i.e. Link Out instead of Link In).
 - Link Bus cables are damaged.
 - Not enough cells are connected to the G5 Cell Interface.
 - Please refer to the Nuvation Energy G5 High-Voltage BMS: NUVG5 Datasheet on the minimum cell voltage required.

8.1.2. Stack Voltage Faults

Stack Over Voltage | stack_fault_voltage_over

- Fault that is triggered when the stack voltage is above the *over* fault threshold.

Stack High Voltage | stack_fault_voltage_hi

- Fault that is triggered when the stack voltage is above the *high* fault threshold.

Stack Low Voltage | stack_fault_voltage_lo

- Fault that is triggered when the stack voltage is below the *low* fault threshold.

Stack Under Voltage | stack_fault_voltage_under

- Fault that is triggered when the stack voltage is below the *under* fault threshold.

Voltage Sum Check | stack_fault_voltage_sum

- Fault that is triggered when the absolute difference between the measured stack voltage and sum of all cell voltages in the stack exceeds the fault threshold.

8.1.2.1. Self Check Issues

These faults have the following Self Check issues:

Fault	Self Check Issues
stack_fault_voltage_hi stack_fault_voltage_lo	AFE is not enabled or misconfigured. Check if ssg_afe_configuration.enabled is set to 1.
stack_fault_voltage_sum	Same issues regarding cell voltage Self Check issues (Section 8.1.1.1, "Self Check Issues").

8.1.3. Thermal Faults

Discharge Under Temperature | stack_fault_discharge_therm_over

- Fault that is triggered when any thermistor measurement is above the *over* fault threshold during discharge.

Discharge High Temperature | stack_fault_discharge_therm_hi

- Fault that is triggered when any thermistor measurement is above the *high* fault threshold during discharge.

Discharge Low Temperature | stack_fault_discharge_therm_lo

- Fault that is triggered when any thermistor measurement is below the *low* fault threshold during discharge.

Discharge Under Temperature | stack_fault_discharge_therm_under

- Fault that is triggered when any thermistor measurement is below the *under* fault threshold during discharge.

Charge Over Temperature | stack_fault_charge_therm_over

- Fault that is triggered when any thermistor measurement is above the *over* fault threshold during charge.

Charge High Temperature | stack_fault_charge_therm_hi

- Fault that is triggered when any thermistor measurement is above the *high* fault threshold during charge.

Charge Low Temperature | stack_fault_charge_therm_lo

- Fault that is triggered when any thermistor measurement is below the *low* fault threshold during charge.

Charge Under Temperature | stack_fault_charge_therm_under

- Fault that is triggered when any thermistor measurement is below the *under* fault threshold during charge.

8.1.3.1. Self Check Issues

All of the temperature measurements are communicated through over the Link Bus using the same mechanism as the cell voltages. Thus, the Self Check failures for the temperature measurements are exactly the same. Refer to [Section 8.1.1.1, "Self Check Issues"](#) for further details.

8.1.4. Stack Current Faults

Discharge Over Current | `stack_fault_discharge_current_over`

- Fault that is triggered when the stack current is above the *over* discharge fault threshold.

Discharge High Current | `stack_fault_discharge_current_hi`

- Fault that is triggered when the stack current is above the *high* discharge fault threshold.

Charge High Current | `stack_fault_charge_current_hi`

- Fault that is triggered when any stack current is above the *high* charge fault threshold.

Charge Over Current | `stack_fault_charge_current_over`

- Fault that is triggered when any stack current is above the *over* charge fault threshold.

Stack/DC-Bus Current Mismatch | `ssg_fault_currents_mismatch`

- Fault when there is a large difference in redundant current measurements.

8.1.4.1. Self Check Issues

The stack current is measured from an internal Analog Front End (AFE) to the G5 Stack Switchgear. The following issues can contribute to these faults not initializing:

1. AFE is not enabled.
2. AFE is misconfigured.

Check if `ssg_afe_configuration.enabled` is set to 1.

8.1.5. Pre-charge Faults

Pre-charge Timeout | `stack_fault_precharge_timeout`

- Fault that is triggered at the end of the pre-charge period. Reasons for fault include:

Pre-charge Error Code	Error Code Description
1	The delay set by <code>stack_control.precharge_delay</code> expired before a current is measured.
2	The measured current exceeds <code>stack_control.precharge_max_current</code> .
3	The measured voltage difference between the battery stack and DC-Bus exceeds <code>stack_control.voltage_mismatch_thresh</code> .

- The value of `stack_control.precharge_error` (listed above) can be used to determine the reason for triggering the fault.

Pre-charge Over Current | stack_fault_precharge_over_current

- Fault that is triggered at any time during the pre-charge connection period if the stack current exceeds the fault threshold.

8.1.5.1. Self Check Issues

These faults are directly related to the current faults detailed previously. Refer to [Section 8.1.4.1, "Self Check Issues"](#) for details.

8.1.6. Contactor Faults

Contactor Feedback Check | stack_fault_contactor_feedback_fail

- Fault that is generated when there is a mismatch between the contactor state and the contactor feedback signal provided. Please check that the Service Disconnect Switch is set to the operating position.

Stack Switchgear Vcoil State Mismatch | ssg_fault_vcoil_state_mismatch

- Fault that is generated when there is a mismatch between the vcoil state and the feedback signal provided. Please check the following:
 - Service Disconnect Switch is set to the operating position
 - The Disconnect input is not asserted based on how it is configured
 - The ssg_vcoil.vcoil_wdt_disable is set to 0 to ensure the external watchdog is not preventing the vcoil from being turned on.

8.1.7. AFE Related Faults

Stack Switchgear AFE Configuration Mismatch | ssg_fault_afe_config_mismatch

- This fault is redundant and can be disabled.

Stack Switchgear AFE Reset | ssg_fault_afe_reset

- This fault indicates an unexpected reset of the AFE subsystem was detected.
- Contact support@nuvationenergy.com if this fault has tripped.

8.1.7.1. AFE BIST Faults

The AFE sub-system incorporates several Built-in-Self-Tests (BISTs) which are monitored through the following faults:

- Stack Switchgear AFE Thermistor BIST Failure | ssg_fault_afe_thermistor_bist
- Stack Switchgear AFE ADC Register BIST Error | ssg_fault_afe_adc_register_bist
- Stack Switchgear AFE SPI Data BIST Error | ssg_fault_afe_spi_data_bist
- Stack Switchgear AFE SPI CS BIST Error | ssg_fault_afe_spi_cs_bist
- Stack Switchgear AFE ROM BIST Watchdog | ssg_fault_afe_rom_bist_fresh_wdt
- Stack Switchgear AFE RAM BIST Watchdog | ssg_fault_afe_ram_bist_fresh_wdt

- Stack Switchgear AFE CPU BIST Watchdog | `ssg_fault_afe_cpu_bist_fresh_wdt`
- Stack Switchgear AFE Thermistor BIST Watchdog | `ssg_fault_afe_thermistor_bist_fresh_wdt`

These faults can be cleared through the Clear Faults button on the Operator Interface.

Please contact support@nuvationenergy.com if any of these faults trip.

AFE Recovery Faults

In Faraday, a Multi-Stack contactor connection event may cause the AFE subsystem to stall causing the following faults to trip:

- `stack_fault_power_wdt`
- `ssg_fault_therms_wdt`
- `ssg_fault_therms_wdt`

If these faults have tripped, the Nuvation Energy BMS can be configured to detect and recover the AFE subsystem before the above faults trip. This is accomplished by enabling the following triggers and setting their associated software watchdogs to expire before the fault software watchdogs expire.

Table 66. AFE Stall Detection Registers

Watchdog Timer Register	Trigger Enable Register
<code>ssg_afe_afe_update_watchdog.period</code>	<code>ssg_trig_afe_afe_update_stalled.disabled</code>
<code>ssg_afe_cpu_bist_update_watchdog.period</code>	<code>ssg_trig_afe_cpu_bist_update_stalled.disabled</code>
<code>ssg_afe_ram_bist_update_watchdog.period</code>	<code>ssg_trig_afe_ram_bist_update_stalled.disabled</code>
<code>ssg_afe_rom_bist_update_watchdog.period</code>	<code>ssg_trig_afe_rom_bist_update_stalled.disabled</code>
<code>ssg_afe_thermistor_bist_update_watchdog.period</code>	<code>ssg_trig_afe_thermistor_bist_update_stalled.disabled</code>
<code>ssg_afe_temperature_update_watchdog.period</code>	<code>ssg_trig_afe_temperature_update_stalled.disabled</code>

The following table provides the recommended configuration values when utilizing stall detection and recovery. Note that the `ssg_fault_afe_reset[0].disabled` register must be set to 1 as the stall detection resets the AFE.

Table 67. Recommended Configurations for Stall Detection

Register	Recommended Value
<code>ssg_trig_afe_temperature_update_stalled[0].disabled</code>	0
<code>ssg_trig_afe_cpu_bist_update_stalled[0].disabled</code>	0
<code>ssg_trig_afe_ram_bist_update_stalled[0].disabled</code>	0
<code>ssg_trig_afe_rom_bist_update_stalled[0].disabled</code>	0
<code>ssg_trig_afe_thermistor_bist_update_stalled[0].disabled</code>	0
<code>ssg_trig_afe_afe_update_stalled[0].disabled</code>	0
<code>ssg_fault_afe_reset[0].disabled</code>	1
<code>stack_power_fresh[0].period</code>	4000000

Register	Recommended Value
ssg_therms_fresh[0].period	4000000
ssg_afe_cpu_bist_fresh[0].period	4000000
ssg_afe_rom_bist_fresh[0].period	4000000
ssg_afe_ram_bist_fresh[0].period	4000000
ssg_afe_fresh[0].period	4000000
ssg_afe_uptime_watchdog[0].period	1000000
ssg_afe_thermistor_bist_update_watchdog[0].period	45000000
ssg_afe_cpu_bist_update_watchdog[0].period	1000000
ssg_afe_ram_bist_update_watchdog[0].period	2000000
ssg_afe_rom_bist_update_watchdog[0].period	2000000
ssg_afe_afe_update_watchdog[0].period	1000000
ssg_afe_temperature_update_watchdog[0].period	1250000

8.1.7.2. Self Check Issues

All of these faults would have a Self Check failure if the AFE has a communication failure. Please refer to [Section 8.1.11, “Watchdog Faults”](#) for the AFE watchdog fault that would trip on this failure.

8.1.8. External Stack Switchgear Faults

The following faults are used to monitor events external to the G5 Stack Switchgear.

Stack Switchgear Power Connector Over Temperature | ssg_fault_power_conn_temp_over

- The temperatures at the power connections for the Stack Switchgear exceeded the threshold of `ssg_fault_power_conn_temp_over.thresh`.
- Refer to the connector temperatures contained in the following registers:
 - `ssg_power_conn_therms[0].temperature` represents the connector temperature at Battery Positive.
 - `ssg_power_conn_therms[1].temperature` represents the connector temperature at Battery Negative.
 - `ssg_power_conn_therms[2].temperature` represents the connector temperature at DC Bus Positive.
 - `ssg_power_conn_therms[3].temperature` represents the connector temperature at DC Bus Negative.
- High temperatures at any of the power connections is an indication of a improperly torqued connection.

Stack Switchgear Power Connector Temperature Consistency |

`ssg_fault_power_conn_temp_consistency`

- Fault indicating the difference amongst temperature measurements of the G5 Stack Switchgear power connections.

- This failure is an indication of a larger thermal build up at one connector compared to the other connections. All four measurements have a thermal delta larger than `ssg_fault_power_conn_temp_consistency.thresh`.
- Please call support@nuvationenergy.com if this fault should trip and report the connection temperatures.

Stack Switchgear GPI Fault | `ssg_fault_gpi`

- Fault that is triggered from an external input on the GPI port.
- Refer to [Section 4.6.1.5, “Externally Activated Fault and Warning”](#) for information on the fault and how its configured.

8.1.8.1. Self Check Issues

The power connector temperature faults (`ssg_fault_power_conn_temp_over` and `ssg_fault_power_conn_temp_consistency`) could fail their Self Check if there was a AFE communication failure. Please refer to [Section 8.1.11, “Watchdog Faults”](#) for the AFE watchdog fault that would trip on this failure.

The GPI fault `ssg_fault_gpi` could fail its Self Check if the GPI associated with the fault was not properly configured.

8.1.9. CI Faults

CI Chain Authentication Test | `sc_fault_ci_auth`

- This fault indicates that the G5 Cell Interface failed its authentication with the G5 Stack Switchgear.
- Call support@nuvationenergy.com if this fault has tripped.

CI Internal Overtemperature | `sc_fault_ci_internal_temp_over`

- This fault indicates that the internal temperature of a G5 Cell Interface exceeded its maximum threshold defined in `sc_fault_ci_internal_temp_over.thresh`.
- This fault could be between a mismatch in the fault configuration and the balancing thermal throttling configuration discussed in [Table 30, “Thermal Throttling Configuration”](#).

CI Chain Thermistor Mux Test Failure | `sc_fault_ci_therm_mux_fail`

- This fault indicates an failure of an multiplexer test internal to a G5 Cell Interface.
- An incorrect wiring of thermistors could cause this fault to trigger.
- The G5 Cell Interface that failed its multiplexer test is identified by the registers `ci[0:19].mux_test_failures`. Each register is a bitfield and any set bit represents a failed channel on the multiplexer test.

8.1.9.1. Known Issues

The G5 High-Voltage BMS may not thermal throttle a cell’s balancing cycle while within the configured hysteresis temperature range for effective thermal management. This may cause the fault

sc_fault_ci_internal_temp_over to trigger.

The workaround is to remove the ability to define a hysteresis temperature range and set the temperature range in which thermal throttling begins to a fixed temperature. This is done by setting the following registers to the same temperature.

1. stack_balancing_throttling_estimator.disable_balancing_temperature
2. stack_balancing_throttling_estimator.enable_balancing_temperature

8.1.9.2. Self Check Issues

All of these faults could fail their Self Test due to a Linkbus communication failure. Refer to [Section 8.1.1.1, "Self Check Issues"](#) for further details on this failure.

8.1.10. DC Fans

DC Fan Control Error | ssg_warn_fan_control_dc_error

- This warning is caused by the hardware fan driver in the G5 Stack Switchgear when it experiences either an over current or over temperature failure when trying to drive the fans. When one of these failures has occurred, the register ssg_fan_control_dc.fault_status will read as one. There is no information available which of these failures has occurred when the warning is triggered. The firmware of the G5 Stack Switchgear will use an auto clear mechanism and the register ssg_fan_control_dc.fault_status may temporarily clear to zero. The register ssg_fan_control_dc.fault_status can be observed to toggle between zero and one while the firmware is trying to auto recover the DC fan failure. When the DC fan failure is corrected, ssg_fan_control_dc.fault_status will stay at zero and DC fan operation will resume. The ssg_warn_fan_control_dc_error will auto clear when the end hysteresis period of ssg_warn_fan_control_dc_error.end_time_hyst of zero output from ssg_fan_control_dc.fault_status has completed.

8.1.10.1. Self Check Issues

This warning should never fail its Self Check. Please check that it has been properly configured as detailed in [Section 4.7.6.3, "DC Fan Warning"](#).

8.1.11. Watchdog Faults

AFE Communication Timeout | ssg_fault_afe_wdt

- Fault indicating communication failure to the AFE subsystem that measures stack voltage/current/charge.

Cell Voltage Measurement Watchdog | stack_fault_cell_wdt

- Fault indicating all cell data has not been updated periodically for every installed cell.

Temperature Measurement Watchdog | stack_fault_therm_wdt

- Fault indicating all thermistor data has not been updated periodically for every installed thermistor.

Cell Interface Measurement Watchdog | `stack_fault_ci_wdt`

- Fault indicating G5 Cell Interface data has not been updated periodically for every installed G5 Cell Interface.

Cell Open Wire Measurement Watchdog | `stack_fault_open_wire_wdt`

- Fault indicating open wire scanning has not been occurring periodically when connected to the DC bus.

Controller Heartbeat Watchdog | `sc_fault_controller_wdt`

- Fault indicating that an external controller to the Battery Management System was not updating its watchdog timer (via the SunSpec heartbeat).

Controller Heartbeat Watchdog | `sc_warn_controller_wdt`

- Warning triggered from the same data as `sc_fault_controller_wdt`.



Transactions on the ModbusTCP interface can occasionally experience significant latency, see [Section 8.3, "ModbusTCP Latency"](#). To prevent tripping `sc_fault_controller_wdt` and `sc_warn_controller_wdt` set the following configuration value:

Configuration Register	Setting
<code>sc_controller_wdt.period</code>	At least 11000000(11 seconds)

Stack Switchgear Temperature Measurements Timeout | `ssg_fault_therms_wdt` and `ssg_fault_power_conn_therms_wdt`

- Fault indicating SSG internal temperatures were not periodically not being measured.

Stack Controller RAM Test Watchdog | `sc_fault_ram_test_wdt`

- Fault indicating the internal RAM testing has not been executing periodically.

Stack Controller ROM Test Watchdog | `sc_fault_rom_test_wdt`

- Fault indicating the internal ROM testing has not been executing periodically.

Stack Switchgear Cpu Register Self Test Watchdog | `ssg_fault_cpu_register_self_test_wdt`

- Fault indicating the CPU register tests had not been executing periodically.

Stack Switchgear Clock Accuracy Test Watchdog | `ssg_fault_clock_accuracy_test_wdt`

- Fault indicating the clock accuracy test had not been executing periodically.

Stack Controller Factory Configuration | `sc_fault_factory_verify_wdt`

- Fault indicating the factory registers on the G5 Stack Switchgear have not been periodically validated against non-volatile memory.

Contactors End-Of-Life Watchdog | `ssg_fault_contactor_end_of_life_wdt`

- Fault indicating contactor life has not been evaluated periodically.

Stack Switchgear Contactor Life Memory Watchdog | `ssg_fault_contactor_life_verify_wdt`

- This watchdog is not required and can be disabled.

8.1.11.1. Self Check Issues

The `stack_fault_cell_wdt`, `stack_fault_therm_wdt`, `stack_fault_ci_wdt`, and `stack_fault_open_wire_wdt` can fail a Self Check due to problems with the Link Bus communication. Refer to [Section 8.1.1.1, "Self Check Issues"](#) for further details.

The watchdog faults `sc_fault_ram_test_wdt`, `sc_fault_rom_test_wdt`, and `sc_fault_factory_verify_wdt` should always pass their Self Check as they are core to the Nuvation Energy BMS and should never fail Self Check.

Please contact Nuvation Energy at support@nuvationenergy.com if you are experiencing these faults.

The `sc_fault_controller_wdt` can fail a Self Check if there is no external controller updating the heartbeat. Disable this fault if is no external controller periodically updating the watchdog as described in [Section 4.6.6, "External Controller Heartbeat"](#).

8.1.12. Configuration Faults

Stack Controller Configuration Consistency Check | `sc_fault_config`

- Fault indicating that there was an error reading the non-volatile storage of the Battery Management System configuration. A default configuration is used when this fault occurs and the Battery Management System will fail to exit Service Lockout. Once a configuration has been successfully imported into the Battery Management System and saved, this fault should not occur.



During a firmware upgrade of the Battery Management System, the configuration is deleted to avoid incompatibility with the upgraded version.

Stack Controller Factory Consistency Check | `sc_fault_config_factory`

- Fault indicating that there was an error reading the non-volatile storage of the Battery Management System factory configuration. This is similar to `sc_fault_config`; refer to that fault for more details.

Stack Controller Factory Memory Check | `sc_fault_config_factory_verify`

- Fault indicating that verification of factory configuration settings against non-volatile storage has failed on the G5 Stack Switchgear. This typically means either a setting was changed after saving or non-volatile memory has been corrupted.

8.1.13. Functional Safety Faults



All of these faults in this section detect a hardware or software failure internal to the G5 High-Voltage BMS. Please contact support@nuvationenergy.com if any of these faults trigger.

Clock Check | `sc_fault_clocks`

- Fault indicating an internal clock failure on the G5 Stack Switchgear.

Register Link | `sc_fault_register_link`

- Fault indicating an internal communication failure in the BMS firmware. If this failure occurs and record the values in the following registers `sc_gpo.link_error`, `sc_gpo_shutdown.link_error`,

`stack_contactor.link_error` and `sc_gpi.link_error`.

Stack Switchgear Vcoil Over Voltage | `ssg_fault_vcoil_voltage_over`

- Fault indicating an Vcoil voltage that was larger than expected.

Stack Switchgear Vcoil Voltage Range | `ssg_fault_vcoil_voltage_range`

- Fault indicating an Vcoil voltage was measured in an unexpected range.

Stack Switchgear Vcoil State Mismatch | `ssg_fault_vcoil_state_mismatch`

- Fault indicating an Vcoil voltage was measured in an state opposite of what was expected.

Stack Switchgear Detected Unexpected Bus Voltage | `ssg_fault_unexpected_bus_voltage`

- Fault indicating that the measured DC Bus voltage was in a state that was not expected.

Stack Switchgear Thermistor Circuit Fail | `ssg_fault_therm_circuit_fail`

- Fault indicating that the internal temperatures of the G5 Stack Switchgear experienced a circuit failure.

Cell Open Wire Test | `stack_fault_cell_open_wire`

- Fault indicating there is an open wire on an installed cell channel.
- This can also trip due to misconfigured or incorrectly installed cells.

Cell Open Wire Test | `stack_warn_cell_open_wire`

- Warning triggering on the same data as `stack_fault_cell_open_wire`.

Thermistor Circuit Test | `stack_fault_therm_circuit_fail`

- Fault indicating there is a circuit failure on a thermistor channel
- This can also trip due to misconfigured or incorrectly installed thermistors.

Thermistor Consistency Check | `stack_fault_ci_therm_consistency`

- Fault indicating the difference amongst external thermal readings per G5 Cell Interface is too large.
- This failure is an indication of either an extreme thermal gradient local to the temperatures measured by one CI or that there is a separation of a thermistor(s) from their intended bonded surface.
- Review all the temperatures of each G5 Cell Interface and identify the Cell Interface that have local temperature deltas greater than the configured threshold `stack_fault_ci_therm_consistency.thresh`.

Cell Interface Measurement Check | `sc_fault_ci`

- Fault indicating there was an internal hardware failure on a G5 Cell Interface.

Stack Switchgear Temperature Short Shunt | `ssg_fault_temperature_short_shunt`

- Fault indicating that the internal G5 Stack Switchgear thermal behavior is correlated with a shorting of its current shunt.

Contactors End-Of-Life | `ssg_fault_contactor_end_of_life`

- Fault indicating a contactor is end-of-life.

Stack Switchgear Contactor Life Memory Error | `ssg_fault_config_contactor_life`

- Fault indicating an error saving or loading the contactor life data.

Stack Switchgear Contactor Life Memory Check | `ssg_fault_config_contactor_life_verify`

- This fault should be disabled. It is not required for G5 High-Voltage BMS operation.

Stack Switchgear Contactor Life Sanity Check | `ssg_fault_contactor_life_sanity_check`

- This fault verifies the internal consistency of data used for contactor life tracking.

8.1.13.1. Self Check Issues

The following faults are related to data from the G5 Cell Interface and can fail a Self Check due to problems with the Link Bus communication.

- `stack_fault_cell_open_wire`
- `stack_fault_therm_circuit_fail`
- `stack_fault_ci_therm_consistency`
- `sc_fault_ci`

Refer to [Section 8.1.1.1, "Self Check Issues"](#) for further details.

The following faults are related to data from the AFE sub-system and can fail a Self Check due to problems communication failures.

- `ssg_fault_therm_circuit_fail`
- `ssg_fault_unexpected_bus_voltage`
- `ssg_fault_temperature_short_shunt`

Please refer to [Section 8.1.11, "Watchdog Faults"](#) for the AFE watchdog fault that would trip on this failure.

Additionally the `ssg_fault_temperature_short_shunt` fault could also fail its a Self Check if the associated algorithm is not enabled (`ssg_temperature_short_shunt_detector.enabled`). Please refer the Nuvation Energy G5 High-Voltage BMS: Safety Manual for details on how to configure this fault properly for a G5 Stack Switchgear model.

8.2. Lost/Forgotten IP Address

If a Nuvation Energy BMS has been configured with a static IP address and it has been forgotten, follow the steps below to recover it.



Depending on the network interface used on the PC, this process may not work due to differing security and IP configurations. If the only IP discovered is the IP of the PC, the network interface is not suitable and another one will need to be used. This issue is most common with USB to Ethernet dongles.

8.2.1. Wireshark (Windows/Linux)

1. Download/install Wireshark on a PC (<https://www.wireshark.org/>)

2. Connect the PC directly to the Ethernet port on the G5 High-Voltage BMS
3. Start a Wireshark capture on the network interface connected to the G5 Stack Switchgear
4. In the 'filter' field, enter in `arp.isgratuitous` and press enter
5. Either reboot the G5 High-Voltage BMS, or unplug/plug the Ethernet cable
6. The device should send a 'Gratuitous ARP' on the Ethernet network. In Wireshark the 'Info' field looks like: Gratuitous ARP for <IP> (Request) where the <IP> is the address for the G5 High-Voltage BMS
7. Once that is complete, update the PC network settings to match the G5 Stack Switchgear and connect the Operator Interface.
 - Refer to [Section 3.5.2, "Setup PC Network Adapter"](#) for instructions.

8.2.2. Netdiscover (Linux only)

1. Install netdiscover on a PC (on Debian based systems use: `sudo apt install netdiscover`)
2. Connect the PC directly to the Ethernet port on the G5 High-Voltage BMS
3. Run `sudo netdiscover -i <interface> -p` where <interface> is the network interface connected to the G5 High-Voltage BMS
4. Either reboot the G5 High-Voltage BMS, or unplug/plug the Ethernet cable
5. The device address and MAC will show up in netdiscover once an ARP packet is sent
6. Once that is complete, update the PC network settings to match the G5 High-Voltage BMS and connect the Operator Interface.
 - Refer to [Section 3.5.2, "Setup PC Network Adapter"](#) for instructions.



In the event the IP address cannot be discovered, a [network reset](#) operation must be carried out to restore the BMS to its factory network configuration.

8.3. ModbusTCP Latency

8.3.1. Known Issue

Transactions over the BMS ModbusTCP interface may occasionally take up to 10 s to complete.

8.4. Disconnect Input Causing Faults to Trip

When using the Disconnect Input, some faults may trip if the system is misconfigured. To avoid tripping faults, set the following configurations based on the disconnect mode. See [Disconnect Input](#) for details on disconnect modes.

Register	Disconnect Mode	Required Setting
<code>ssg_fault_vcoil_state_mismatch.time_hyst</code>	Quick	Greater than or equal to <code>stack_control.disconnect_delay</code>

Register	Disconnect Mode	Required Setting
stack_fault_contactor_feedback_fail.time_hyst	Quick	Greater than or equal to stack_control.disconnect_delay
ssg_fault_vcoil_state_mismatch.time_hyst	Nominal	Greater than or equal to stack_control.disconnect_delay -6000000 (minimum: 0)
stack_fault_contactor_feedback_fail.time_hyst	Nominal	Greater than or equal to stack_control.disconnect_delay -6000000 (minimum: 0)

Appendix A: Ordering Information

G5 Stack Switchgear

Product part numbers for ordering a G5 Stack Switchgear are listed below.

Table 68. G5 Stack Switchgear Unit Ordering Information

Part Number	Product Name	Continuous Rated Current	Maximum Rated Current	Compatible Fuse Rating
NUVG5-SSG-1500-200-x	G5 Stack Switchgear, 1500 V, 200 A	200 A	250 A	200 A, 250 A, 315 A
NUVG5-SSG-1500-300-x	G5 Stack Switchgear, 1500 V, 300 A	300 A	350 A	315 A, 350 A, 400 A, 450 A, 500 A
NUVG5-SSG-1500-350-x	G5 Stack Switchgear, 1500 V, 350 A	350 A	400 A	350 A, 400 A, 450 A, 500 A

* x = fuse rating code.



Kits are available for purchase online at <https://nstore.nuvationenergy.com>. These kits include the product, cables, and any accessories needed to get you started.

Fuse Rating Code

The fuse rating code is denoted by the x at the end of the product part number. The G5 Stack Switchgear fuse rating is determined by the application power profile, which is based on continuous power, cycle duration, and cycle frequency.

A Nuvation Energy Application Engineer will assist with determining a suitable fuse rating when an order is placed.

Table 69. Fuse rating and code

Fuse Rating	Code
200 A	1
250 A	2
315 A	3
350 A	4
400 A	5
450 A	6
500 A	7

For e.g., a NUVG5-SSG-1500-200-1 is a "1500 V DC, 200 A" G5 Stack Switchgear, with a 200 A fuse rating.

By default, the G5 Stack Switchgear ships with bracket NUVP-SSG-SB-B for shelf-mounting. The following mounting bracket options are available upon request.

Table 70. Mounting Bracket Ordering Information

Part Number	Product Name
NUVP-SSG-SB-B	Part, Stack Switchgear, Brackets for shelf-mounting
NUVP-SSG-RB-19-B	Part, Stack Switchgear, Front-securing Brackets for 19" Rack

Fasteners for attaching the brackets to the unit are included.



Bracket CAD files are available online at <https://www.nuvationenergy.com/technical-resources>.

G5 Cell Interface

Product part numbers for ordering a G5 Cell Interface are listed below.

Table 71. G5 Cell Interface Ordering Information

Part Number	Product Name
NUVG5-CI-24	G5 Cell Interface - 24 channel



Kits are available for purchase online at <https://nstore.nuvationenergy.com>. These kits include the product, cables, and any accessories needed to get you started.

Appendix B: Mating Connectors

G5 Stack Switchgear Connectors

Power and Fan Connector



Molex 39-01-2105	
Manufacturer	Molex
Housing	39-01-2105
Housing material	Nylon UL94V-0
Circuits	10
Crimp terminal	39-00-0073 (Reel)
Wire gauge range	18–24 AWG stranded

Table 72. Power and Fan Connector Pin Assignment

Pin	Connection	Description	Connected to Device
1	AC_IN_N	AC Power In, Neutral	External AC power source
2	AC_FAN_OUT_N	AC Fan Power Out, Neutral	Battery rack AC cooling fans
3	AC_EARTH	AC Earth; connected internally to Pin 8 ¹	AC Ground connection
4	DC_PWR_NEG	DC Power In, Negative	External DC power source
5	DC_FAN_NEG	DC Fan Power Out, Negative	Battery rack DC cooling fans
6	AC_IN_L	AC Power In, Line	External AC power source ³
7	AC_FAN_OUT_L	AC Fan Power Out, Line	Battery rack AC cooling fans
8	AC_EARTH	AC Earth; connected internally to Pin 3 ¹	AC Ground connection
9	DC_PWR_POS	DC Power In, Positive	External DC power source ²
10	DC_FAN_POS	DC Fan Power Out, Positive	Battery rack DC cooling fans

¹Also connected internally to G5 Stack Switchgear chassis

²Powers the G5 Stack Switchgear if the external AC power source is unavailable. Powers the external DC fans

³Powers the G5 Stack Switchgear and the external AC fans

I/O Connector

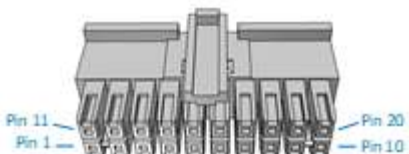

Samtec IPD1-10-D-K	
Manufacturer	Samtec Incorporated
Housing	IPD1-10-D-K
Housing material	Nylon UL94V-0
Circuits	20
Crimp terminal	CC79R-2024-01-L (Reel)
Wire gauge range	20–24 AWG stranded

Table 73. I/O Connector Pin Assignment

Pin	Connection	Description	Connected to Device
1	COM_CHAIN	Negative reference for chained G5 Stack Switchgear	Next G5 Stack Switchgear COM in the chain
2	ENABLE#_CHAIN	Connected internally to Pin 14	Next G5 Stack Switchgear Enable input in the chain
3	SHUTDOWN#_COM	Signal return for Shutdown input	External equipment
4	ENABLE#_COM	Signal return for Enable input	External equipment
5	DISCONNECT#	Connect to COM_IO to open contactors	External equipment
6	DISCONNECT#_COM_IO	Signal return for Disconnect input	External equipment
7	GPO_ISO1_A	Digital Output 1	External equipment
8	GPO_ISO0_A	Digital Output 0	External equipment
9	GPI_ISO1_COM_IO	Signal return for GPI_ISO1_K input	External equipment
10	GPI_ISO0_COM_IO	Signal return for GPI_ISO0_K input	External equipment
11	COM	Signal return from G5 Stack Switchgear	Next G5 Stack Switchgear COM in the chain
12	SHUTDOWN#_CHAIN	Connected internally to Pin 13	Next G5 Stack Switchgear Shutdown input in the chain
13	SHUTDOWN#	Momentary to COM to invoke shutdown; Hold to COM to force shutdown	External equipment
14	ENABLE#	Momentary to COM to enable G5 Stack Switchgear; Hold to COM to defeat Shutdown	External equipment
15	DISCONNECT#_CHAIN	Connected internally to Pin 5	Next G5 Stack Switchgear Disconnect input in the chain
16	COM_IO_CHAIN	Negative isolated reference for chained G5 Stack Switchgear	Next G5 Stack Switchgear COM_IO in the chain
17	GPO_ISO1_B	Digital Output 1	External equipment
18	GPO_ISO0_B	Digital Output 0	External equipment

Pi n	Connection	Description	Connected to Device
19	GPI_ISO1_K	Input detector 1	External equipment
20	GPI_ISO0_K	Input detector 0	External equipment

General Purpose Output

The following diagram shows the internal circuit driving the GPO outputs. Refer to [Section 5.1.1.1, "External Specifications"](#) for the electrical ratings of this output.

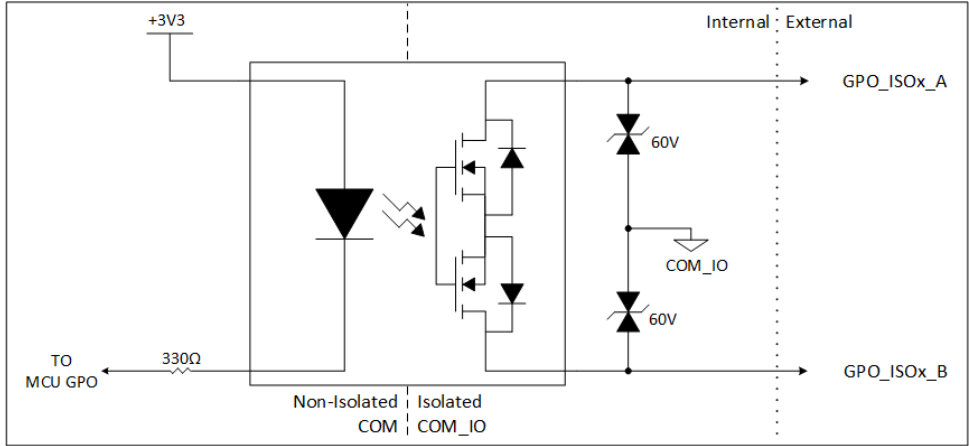

Figure 85. GPO Equivalent Circuit Diagram

General Purpose Input

The following diagram shows the internal circuit receiving the GPI inputs. Refer to [Section 5.1.1.1, "External Specifications"](#) for the electrical ratings of this input.

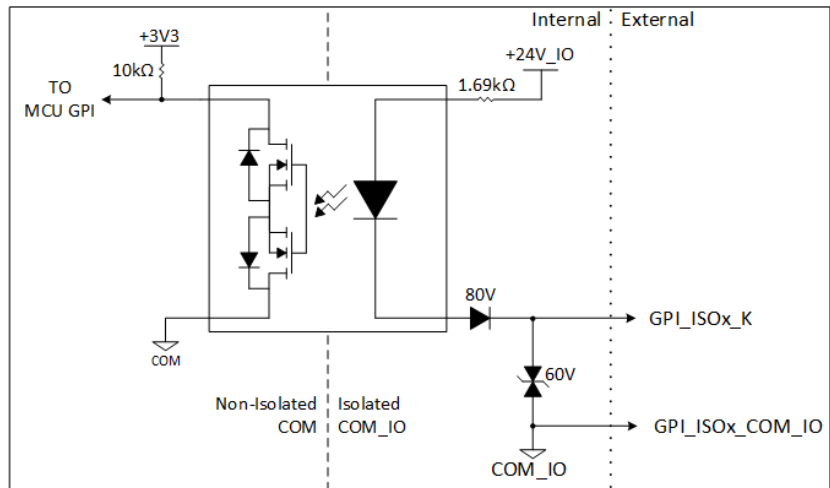

Figure 86. GPI Equivalent Circuit Diagram

Disconnect Input

The following diagram shows the internal circuit receiving the Disconnect input. This feature allows an external dry-contact switch to notify the G5 Stack Switchgear to disconnect the battery from the DC bus. The signal can be daisy-chained to adjacent G5 Stack Switchgear units that also share the same DC bus.

The Disconnect input requires the signal to be asserted for a minimum of 0.5 seconds when the G5 Stack Switchgear is configured for normal disconnect mode. When configured for fast disconnect mode, the G5 Stack Switchgear instantly reacts to the input.

In the unlikely event the G5 Stack Switchgear is unresponsive, asserting the Disconnect Input for 10 seconds will override the software to disconnect the battery from the DC Bus using a hardware-only circuit. Refer to [Section 5.1.1.1, "External Specifications"](#) for the electrical ratings of this input.

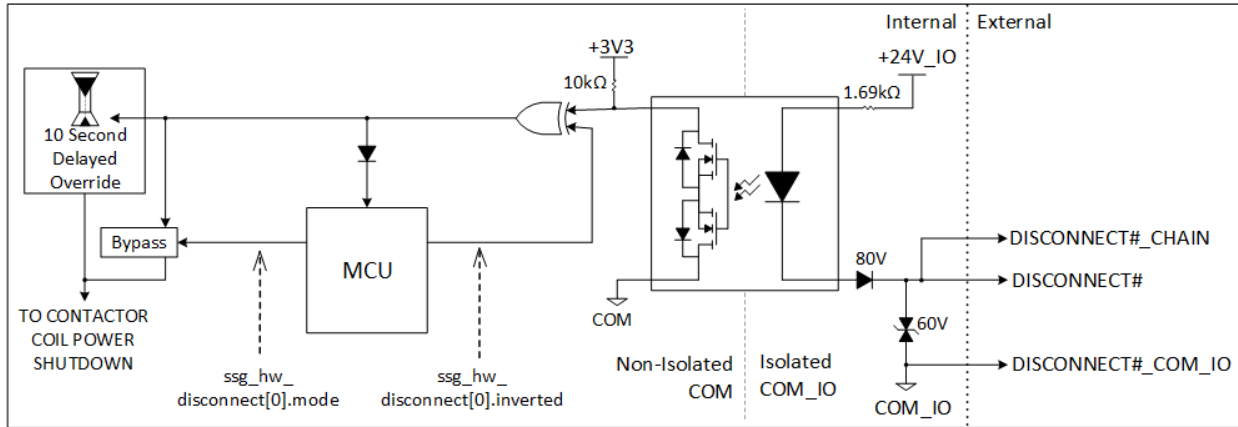

Figure 87. Disconnect Input Equivalent Circuit Diagram

Enable Input

The following diagram shows the internal circuit receiving the Enable input. The Enable circuit must be controlled by a momentary switch or relay that will assert the signal for a minimum of 2 seconds. Holding the signal asserted will defeat the Shutdown input and defeat the ability for a UVLO fault to turn off the BMS. Refer to [Section 5.1.1.1, "External Specifications"](#) for the electrical ratings of this input.

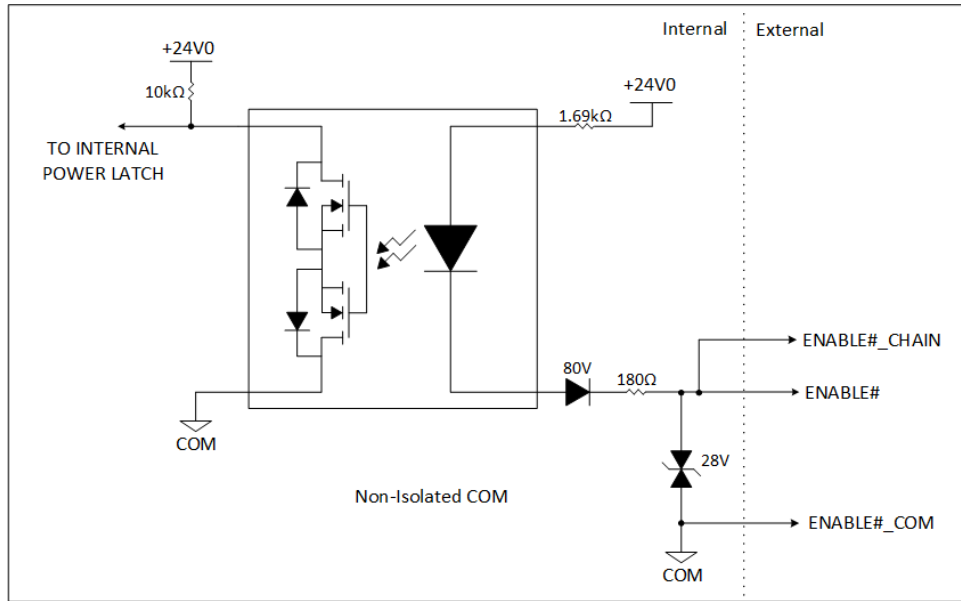

Figure 88. Enable Input Equivalent Circuit Diagram

Shutdown Input

The following diagram shows the internal circuit receiving the Shutdown input. The Shutdown circuit must be controlled by a switch or relay that will assert the signal for a minimum of 0.5 seconds. Holding the signal asserted for 10 seconds will trigger the hardware-only circuit path which will force the BMS to turn off if the BMS Firmware is non-responsive, unless the Enable input is asserted. Refer to [Section 5.1.1.1, “External Specifications”](#) for the electrical ratings of this input.

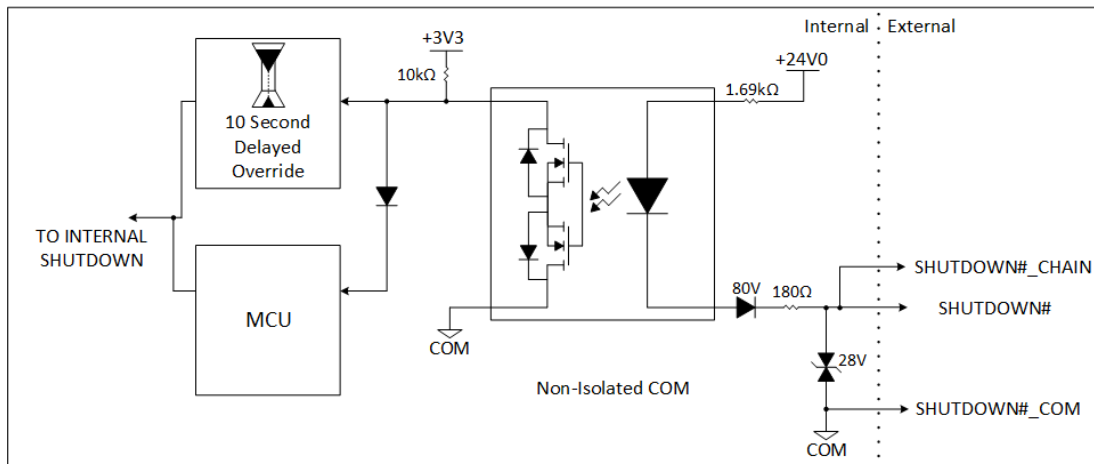

Figure 89. Shutdown Input Equivalent Circuit Diagram

Multi-Stack Chain Pin Assignments::

In a multi-stack battery energy storage system, it can be desirable to use a global relay or switch to send an Enable, Shutdown, or Disconnect signal to all G5 Stack Switchgears simultaneously. The system wiring can be simplified by making use of the Chain signals provided on this connector. Each G5 Stack Switchgear will contribute a small amount of current into the global relay or switch. The

path within the G5 Stack Switchgear is rated for a maximum current of 1.5A which equals approximately 100 G5 Stack Switchgears. In practice, the limit will be the wire gauge size and global relay or switch, which must be rated to switch 24 VDC at 15mA times the number of G5 Stack Switchgears. Refer to [Section 5.1.1.1, "External Specifications"](#) for the electrical ratings of this output.

Multi-stack chain pin assignments are shown below for Enable and Shutdown input signal circuits.

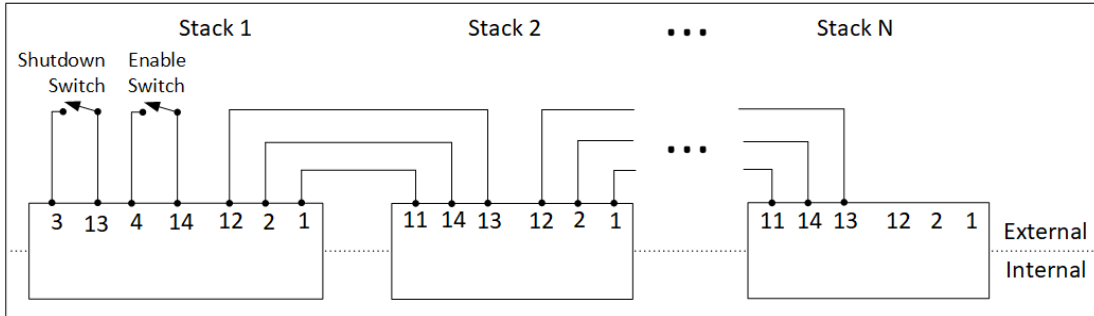

Figure 90. Enable and Shutdown Chain Pin Assignments

Multi-stack chain pin assignments are shown below for Disconnect input signal circuits.

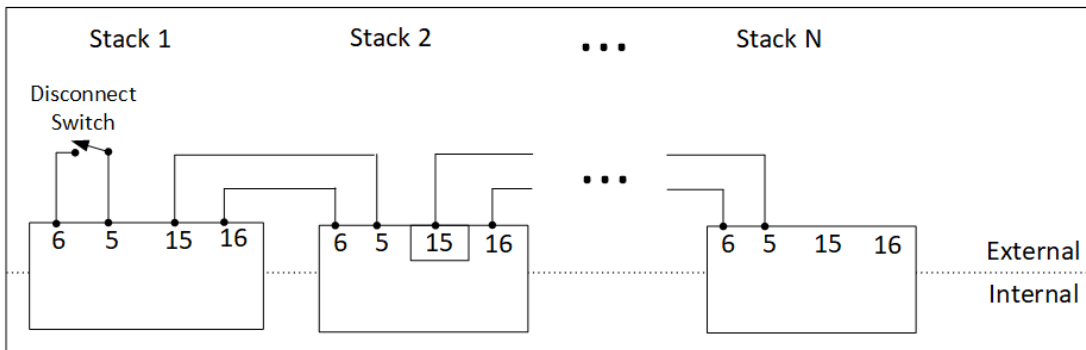

Figure 91. Disconnect Chain Pin Assignments

Linkbus Connector

The Linkbus jack is a standard RJ45 Cat5e rated jack.

Table 74. Linkbus Connector Pin Assignment

Pin	Connection	Description	Connected to Device
1	No Connect	No Connection	No Connection
2	No Connect	No Connection	No Connection
3	No Connect	No Connection	No Connection
4	No Connect	No Connection	No Connection
5	No Connect	No Connection	No Connection
6	No Connect	No Connection	No Connection

Pin	Connection	Description	Connected to Device
7	IMA	Link Bus differential pair negative	First G5 Cell Interface module in the Link Bus chain
8	IPA	Link Bus differential pair positive	First G5 Cell Interface module in the Link Bus chain

Ethernet Connector

The Ethernet jack is a standard RJ45 Cat5e rated jack.

Table 75. Ethernet Connector Pin Assignment

Pin	Connection	Description	Connected to Device
1	TD_P	Transmit differential pair positive	External equipment
2	TD_N	Transmit differential pair negative	External equipment
3	RD_P	Receive differential pair positive	External equipment
4	NUL45	Unused; connected to Pin 5 and terminated	External equipment
5	NUL45	Unused; connected to Pin 4 and terminated	External equipment
6	RD_N	Receive differential pair, negative	External equipment
7	NUL_78	Unused; connected to Pin 8 and terminated	External equipment
8	NUL_78	Unused; connected to Pin 7 and terminated	External equipment

Battery and DC Bus High Current Connectors

The 4 high current posts accept an M10-1.5 Stainless-Steel bolt which is used to secure the high current wire lug. G5 Stack Switchgear includes 16 mm long bolt and split lock-washer. The bolt must be tightened to 60 to 80 in-lbs.

The provided cable insulation boots must be used to insulate each high current post. The red boots are used for *Battery+* and *DC Bus+* positive connections; the black boots are used for *Battery-* and *DC Bus-* negative connections. Maximum cable O.D. (including insulation thickness) is 0.8in [20.3mm]. Wire crimp lug must not extend beyond the center of the M10 clearance hole by 1.3in [33mm].

Earth Bonding Connector

The equipment Earth bonding post accepts an M8-1.25 Zinc-plated bolt which is used to secure the Earth wire lug. G5 Stack Switchgear includes 16mm long bolt and 2 external-toothed lock-washers where one washer is placed between the G5 Stack Switchgear and the grounding lug and the other washer is placed between the grounding lug and the bolt head. The bolt must be tightened to 130 in-lbs. Refer to NFPA 70, Table 250.122 for suitable wire size based on the G5 Stack Switchgear unit's current rating.

G5 Cell Interface Connectors

Cell Voltage and Temperature Connector

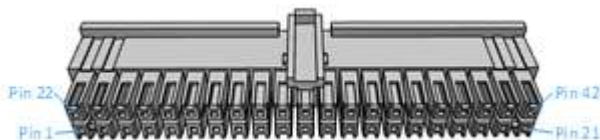

Samtec IPD1-21-D-K	
Manufacturer	Samtec Incorporated
Housing	IPD1-21-D-K
Housing material	Nylon UL94V-0
Circuits	42
Crimp terminal	CC79R-2024-01-L (Reel)
Wire gauge range	20–24 AWG stranded



Samtec IPD1-21-D-K suggested wire:
UL Style 3239, 24 AWG, 150° C, 3KV, 1.9 mm O.D.
Example: 3239-24-1-0500-001-1-TS

Table 76. Cell Voltage and Temperature Connector Pin Assignment

Pin	Connection	Description	Connected to Device
1	CELL23+	Cell 23 voltage sense	Connect to positive terminal of Cell 23
2	CELL24+	Cell 24 voltage sense	Connect to positive terminal of Cell 24
3	<i>Reserved – Do not populate</i>		
4	TEMP1	External temperature probe input 1	10 kΩ NTC Thermistor #1
5	TCOM	External temperature probe reference	10 kΩ NTC Thermistor #1
6	TEMP2	External temperature probe input 2	10 kΩ NTC Thermistor #2
7	TCOM	External temperature probe reference	10 kΩ NTC Thermistor #2
8	TEMP3	External temperature probe input 3	10 kΩ NTC Thermistor #3
9	TCOM	External temperature probe reference	10 kΩ NTC Thermistor #3
10	TEMP4	External temperature probe input 4	10 kΩ NTC Thermistor #4
11	TCOM	External temperature probe reference	10 kΩ NTC Thermistor #4
12	TEMP5	External temperature probe input 5	10 kΩ NTC Thermistor #5
13	TCOM	External temperature probe reference	10 kΩ NTC Thermistor #5
14	TEMP6	External temperature probe input 6	10 kΩ NTC Thermistor #6
15	TCOM	External temperature probe reference	10 kΩ NTC Thermistor #6
16	TEMP7	External temperature probe input 7	10 kΩ NTC Thermistor #7
17	TCOM	External temperature probe reference	10 kΩ NTC Thermistor #7

Pin	Connection	Description	Connected to Device
18	TEMP8	External temperature probe input 8	10 kΩ NTC Thermistor #8
19	TCOM	External temperature probe reference	10 kΩ NTC Thermistor #8
20	CI_REF1-	Bottom reference of G5 Cell Interface	Connect to negative terminal of the lowest cell (Cell 1)
21	CELL1+	Cell 1 voltage sense	Connect to positive terminal of the lowest cell (Cell 1)
22	CELL22+	Cell 22 voltage sense	Connect to positive terminal of Cell 22
23	CELL21+	Cell 21 voltage sense	Connect to positive terminal of Cell 21
24	CELL20+	Cell 20 voltage sense	Connect to positive terminal of Cell 20
25	CELL19+	Cell 19 voltage sense	Connect to positive terminal of Cell 19
26	CELL18+	Cell 18 voltage sense	Connect to positive terminal of Cell 18
27	CELL17+	Cell 17 voltage sense	Connect to positive terminal of Cell 17
28	CELL16+	Cell 16 voltage sense	Connect to positive terminal of Cell 16
29	CELL15+	Cell 15 voltage sense	Connect to positive terminal of Cell 15
30	CELL14+	Cell 14 voltage sense	Connect to positive terminal of Cell 14
31	CELL13+	Cell 13 voltage sense	Connect to positive terminal of Cell 13
32	CELL12+	Cell 12 voltage sense	Connect to positive terminal of Cell 12
33	CELL11+	Cell 11 voltage sense	Connect to positive terminal of Cell 11
34	CELL10+	Cell 10 voltage sense	Connect to positive terminal of Cell 10
35	CELL9+	Cell 9 voltage sense	Connect to positive terminal of Cell 9
36	CELL8+	Cell 8 voltage sense	Connect to positive terminal of Cell 8
37	CELL7+	Cell 7 voltage sense	Connect to positive terminal of Cell 7
38	CELL6+	Cell 6 voltage sense	Connect to positive terminal of Cell 6
39	CELL5+	Cell 5 voltage sense	Connect to positive terminal of Cell 5
40	CELL4+	Cell 4 voltage sense	Connect to positive terminal of Cell 4
41	CELL3+	Cell 3 voltage sense	Connect to positive terminal of Cell 3
42	CELL2+	Cell 2 voltage sense	Connect to positive terminal of Cell 2

Link In Connector

The Link In jack is a standard RJ45 Cat5e rated jack.

Table 77. Link In Connector Pin Assignment

Pin	Connection	Description	Connected to Device
1	No Connect	No Connection	No Connection
2	No Connect	No Connection	No Connection
3	No Connect	No Connection	No Connection
4	No Connect	No Connection	No Connection
5	No Connect	No Connection	No Connection

Pin	Connection	Description	Connected to Device
6	No Connect	No Connection	No Connection
7	IMA	Link Bus differential pair negative	Previous G5 Cell Interface in the Link Bus chain or the G5 Stack Switchgear
8	IPA	Link Bus differential pair positive	Previous G5 Cell Interface in the Link Bus chain or the G5 Stack Switchgear

Link Out Connector

The Link Out jack is a standard RJ45 Cat5e rated jack.

Table 78. Link Out Connector Pin Assignment

Pin	Connection	Description	Connected to Device
1	No Connect	No Connection	No Connection
2	No Connect	No Connection	No Connection
3	No Connect	No Connection	No Connection
4	No Connect	No Connection	No Connection
5	No Connect	No Connection	No Connection
6	No Connect	No Connection	No Connection
7	IMA	Link Bus differential pair negative	Subsequent G5 Cell Interface module in the Link Bus chain
8	IPA	Link Bus differential pair positive	Subsequent G5 Cell Interface module in the Link Bus chain

<<

Appendix C: Battery Topology Terminology

Energy storage systems are hierarchical in nature. Nuvation Energy has adopted the following definitions for battery pack topology:

Cell

A Cell is the smallest unit of energy storage distinguishable by the Battery Management System. One Cell, as defined from the perspective of the BMS, may actually consist of one or more electrochemical cells connected in parallel. This subtlety is reflected in the nomenclature for completeness. For example, a "1p" Cell refers to a single electrochemical cell, while a "2p" Cell refers to two electrochemical cells connected together in parallel. From the perspective of the BMS, these topologies appear identical except for the capacity of the Cells.

Group

A Group is a set of Cells connected in series and managed together. For example, 12 "1p" Cells in series are referred to as a "12s1p" Group, while 16 "2p" Cells in series are referred to as a "16s2p" Group. Grouping of Cells is highly application-specific and is defined in how BMS hardware interfaces are physically wired up to Cells.

Stack

A Stack is one or more Groups connected in series. For example, five "14s2p" Groups connected in series could be described as a "5g14s2p" Stack. However, it is far more common to describe it as a "70s2p" Stack.

Bank

A Bank is one or more stacks connected in parallel. For example, three "70s2p" Stacks connected in parallel are referred to as a "3x70s2p" Bank.

Pack

A Pack is one or more Banks connected in series.

Appendix D: Best Practices

This section describes important concepts which need special attention to achieve a reliable installation.

Excess Cable Management

During the first prototype system build, it is possible to encounter cable lengths that are too long for your system. Leaving the excess cable length unmanaged can result in a messy system installation.

If reducing the cable length is not feasible or if there is no time to physically modify the lengths, a common solution is to wrap the excess cable length in a coil and fasten the wire loop in the cabinet. This basic tactic has the undesirable effect of creating an air-core transformer which will couple EMI into the cable extremely well.

The best solution to cable length management is to bundle the excess length in a figure-8 pattern. This prevents the bundle from turning into an air-core transformer since the direction of current in one side of the figure-8 turns opposite to the current in the other side. It is recommended to use the figure-8 method if physically reducing the cable length is not possible.

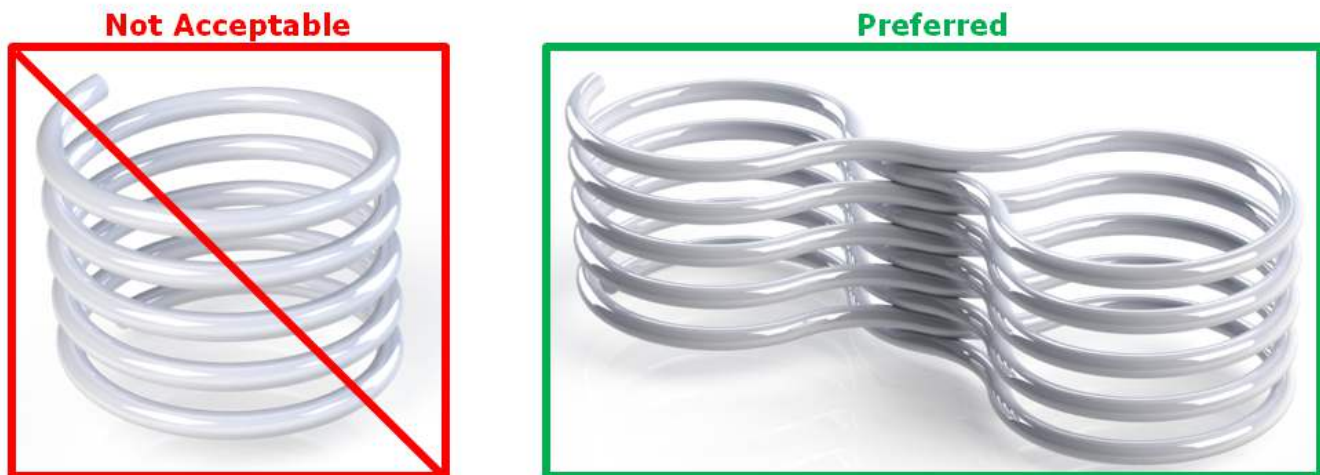

Figure 92. Excess Cable Management Examples

Security



This section is provided as guidance only and experts in security and the broader system must be consulted on any security decisions.



Security for the entire system and site must be considered, not just for individual Nuvation Energy products.

It is recommended evaluating each site and system to assess the risk level and impacts of the system not operating properly. Security restrictions protect against both accidental misuse and intentional

attacks. Each added layer of security will impact the ability to diagnose and resolve system problems and analyze system performance. The costs of system security should be proportional to the risk level of that system.

The sections below outline the best practices for maintaining a secure system.

Physical Security

Physical security measures are designed to deny unauthorized physical access to Nuvation Energy products and the larger systems. Physical security can include barriers, locks, access control, surveillance, guards, intrusion detection/alarms, and other physical security systems.

Ensuring all equipment is physically secure is the first and most important step in protecting the system. Below are some recommended best practices for the physical security of the products:

- Nuvation Energy products should be physically secured in a locked enclosure, room, or building to restrict access. This physically secured area will be referred to as the 'secure zone'.
- The 'secure zone' access should be restricted to authorized personnel only.
- Authorized personnel should be trained to operate the equipment and follow the security process.
- Any unauthorized personnel should be supervised at all times.

Outside the products themselves, access to equipment and connections should also be secured, such as:

- Cells/battery modules
- PCS/inverters
- SCADA systems
- UPS/emergency power equipment
- High and low power cables and measurement wires
- Communication cables (i.e. Ethernet, USB, Linkbus, Stackbus, etc.)
- Networking equipment (i.e. routers, switches, transceivers, etc.)
- Buttons/control panels (i.e. E-stop, touchscreens, etc.)
- Any other critical equipment/connections that might compromise the site

Network Security

The networking on Nuvation Energy products uses Ethernet-based TCP/IP communications. Throughout this section, references to the nController apply to both Nuvation Energy Multi-Stack Controller and Energy Management System products. A network security analysis for any third party equipment on the network should be conducted in consultation with the equipments' manufacturer. Below are some recommended best practices for network security of Nuvation Energy products:

- Nuvation Energy products should be on an isolated network where only trusted equipment can operate, and trusted personnel can access. This network will be referred to as the 'secure network'.

- The 'secure network' should be within the 'secure zone' (see the [Physical Security](#) for details)
- The 'secure network' should be established through either a:
 - Physically isolated network (i.e. no connection to any other network, otherwise known as 'air gapped')
 - Firewall isolated network (i.e. router, smart switch, or other equipment with packet filtering to the 'secure network')
- The nController should be used to isolate the stack BMSs from the site network through the nController 'Internal/Bridge' network. These two networks must be isolated on separate subnetworks with separated IP address ranges.

An example of a 'secure network' topology with a router based firewall, Multi-Stack Controller, and G5 Stack Switchgear units isolated on the 'Internal/Bridge' network is below:

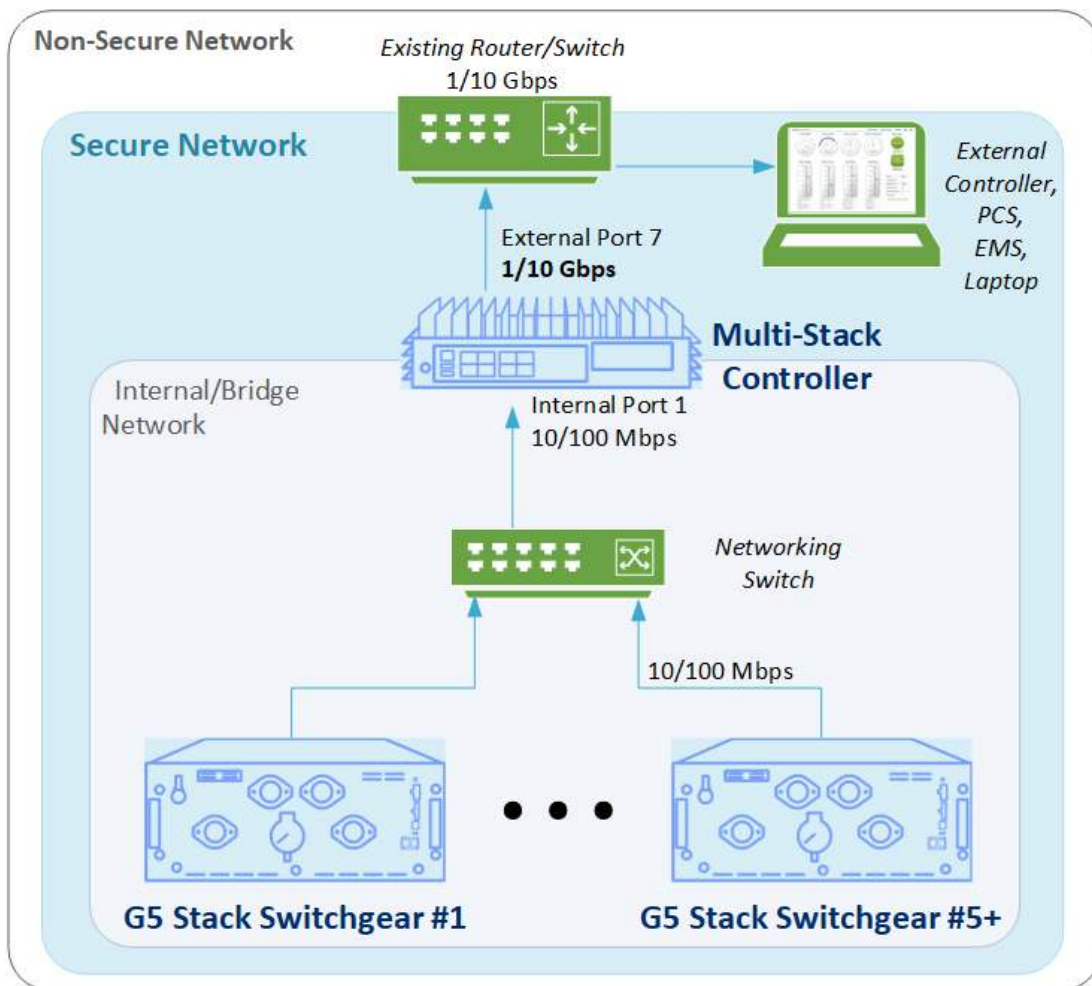

Figure 93. Networking configuration for a Multi-Stack Controller with secure and internal network

Inbound Protocols and Ports

All the open ports listening on the G5 High-Voltage BMS with the network protocols are listed below.

Unless specified, the protocols are not encrypted or authenticated.

- TCP Port 80 (HTTP)
- TCP Port 502 (Modbus)

Outbound Protocols

All Nuvation Energy products implement the essential outbound services for proper operation with modern networking equipment, listed below. Unless specified, the protocols are not encrypted or authenticated.

- Broadcast on network segment (ARP, STP)
- UDP Port 67/68 (DHCP)

Blocking outbound protocols can be done in a similar way to inbound protocols (i.e. firewalls). For more information on the above services and to configure or disable services, contact support@nuvationenergy.com. Some services such as mDNS cannot be disabled.

Operator Interface Unlock Password

The Operator Interface for both single and multi-stack systems can be configured with a password which restricts some features in the products. The unlock password protects against accidental misuse of the products during normal operation.



The Operator Interface uses HTTP which does not encrypt connections and requires a secured network to protect against malicious intent.

Appendix E: BMS Network Configuration

Nuvation Energy BMS is flexible and allows changing its network configuration if you need the IP address of Nuvation Energy BMS to match your existing network settings.



Improperly modifying the network settings can result in a Nuvation Energy BMS that cannot communicate over Ethernet.

Be sure to record the updated IP address, netmask, and gateway settings if you decide to make changes to these settings.

Modifying the Network Settings



The G5 High-Voltage BMS ships from the factory with password protection on the Operator Interface. Please contact support@nuvationenergy.com for the factory password and documentation for advanced modifications of the G5 High-Voltage BMS.

1. Unlock the Operator Interface by clicking the menu and UnLock
 - You will need the Operator Interface password if the Operator Interface is password-protected
2. Follow the instructions in [Section 5.3.3.2.5, "Editing an IP Address"](#) to update the IP.

From time to time Nuvation Energy will make updates to products in response to changes in available technologies, client requests, emerging energy storage standards, and other industry requirements. The product specifications in this document, therefore, are subject to change without notice.

© 2024 Nuvation Energy

Registers

A

AFE Communication Timeout, [186](#)

C

cell

installed, [66](#), [66](#)

Cell High Voltage, [179](#)

Cell Interface Measurement Check, [189](#)

Cell Interface Measurement Watchdog, [187](#)

Cell Low Voltage, [179](#)

Cell Open Wire Measurement Watchdog, [187](#)

Cell Open Wire Test, [189](#), [189](#)

Cell Over Voltage, [178](#)

Cell Under Voltage, [179](#)

Cell Voltage Measurement Watchdog, [186](#)

Charge High Current, [181](#)

Charge High Temperature, [180](#)

Charge Low Temperature, [180](#)

Charge Over Current, [181](#)

Charge Over Temperature, [180](#)

Charge Under Temperature, [180](#)

ci

max_ci_temperature, [173](#)

mux_error, [185](#)

CI Chain Authentication Test, [185](#)

CI Chain Thermistor Mux Test Failure, [185](#)

CI Internal Overtemperature, [185](#)

Clock Check, [188](#)

Contactor End-Of-Life, [189](#)

Contactor End-Of-Life Watchdog, [187](#)

Contactor Feedback Check, [182](#)

Controller Heartbeat Watchdog, [187](#), [187](#)

Current Shunt Short Circuit Check, [189](#)

D

DC Fan Control Error, [186](#)

Discharge High Current, [181](#)

Discharge High Temperature, [180](#)

Discharge Over Current, [181](#)

Discharge Under Temperature, [180](#), [180](#)

P

Pre-charge Over Current, [182](#)

Pre-charge Timeout, [181](#)

R

Register Link, [189](#)

S

sc_controller_wdt, [115](#)

period, [79](#), [187](#)

sc_fault_ci, [189](#), [190](#)

sc_fault_ci_auth, [185](#)

sc_fault_ci_internal_temp_over, [185](#)

sc_fault_ci_therm_mux_fail, [185](#)

sc_fault_clocks, [188](#)

sc_fault_config, [188](#)

sc_fault_config_factory, [188](#)

sc_fault_config_factory_verify, [188](#)

sc_fault_controller_wdt, [187](#)

disabled, [79](#)

sc_fault_ram_test_wdt, [187](#)

sc_fault_register_link, [189](#)

sc_fault_rom_test_wdt, [187](#)

sc_gpi

address, [98](#), [98](#)

address_enabled, [97](#)

falling_edge_triggered, [98](#)

inverted, [98](#), [98](#)

rising_edge_triggered, [98](#), [98](#)

sc_gpo

address, [97](#), [97](#)

address_enabled, [97](#)

inverted, [97](#), [97](#)

sc_gpo_fault_pilot

fault_delay, [109](#)

fault_enabled, [109](#)

sc_gpo_shutdown

address, [110](#)

address_enabled, [110](#)

inverted, [110](#)

sc_linkbus

actual_scan_period, [107](#)

balance_settle_period, [107](#)

cell_open_wire_disabled, [108](#)

cell_open_wire_max, [108](#)

cell_open_wire_period, [108](#)

cell_open_wire_ratio_lower, [108](#)

cell_open_wire_ratio_upper, [108](#)

cell_open_wire_thresh, [108](#)

cell_voltage_lpf_bw, [107](#)

cicount, [66](#)

powermode, [66](#)

scan_period, [106](#)

softwareid, [66](#)

sc_ram_test_wdt, [115](#)

[sc_rom_test_wdt, 115](#)
[sc_warn_controller_wdt, 187](#)
[ssg_afe_afe_update_watchdog, 183, 184](#)
[ssg_afe_configuration.enabled, 180, 181](#)
[ssg_afe_cpu_bist_fresh, 184](#)
[ssg_afe_cpu_bist_update_watchdog, 183, 184](#)
[ssg_afe_fresh, 184](#)
[ssg_afe_ram_bist_fresh, 184](#)
[ssg_afe_ram_bist_update_watchdog, 183, 184](#)
[ssg_afe_rom_bist_fresh, 184](#)
[ssg_afe_rom_bist_update_watchdog, 183, 184](#)
[ssg_afe_temperature_update_watchdog, 183, 184](#)
[ssg_afe_thermistor_bist_update_watchdog, 183, 184](#)
[ssg_afe_uptime_watchdog, 184](#)
[ssg_ambient_therm](#)
 [temperature, 174](#)
 [temperature_float, 174](#)
[ssg_bus_fault_discharge_current_over](#)
 [thresh, 76](#)
[ssg_bus_power](#)
 [current_gain, 104](#)
 [current_gain_limit, 104](#)
 [voltage_gain, 106](#)
 [voltage_gain_limit, 106](#)
[ssg_contactor_life_tracker](#)
 [current_capture_window, 114](#)
 [enabled, 114](#)
 [life_remaining, 174](#)
 [max_life, 114](#)
 [max_opening_current, 114](#)
 [max_rated_current, 114](#)
 [min_opening_current, 114](#)
[ssg_enable](#)
 [value, 101](#)
[ssg_factory_restore_0](#)
 [value, 101](#)
[ssg_factory_restore_1](#)
 [value, 100](#)
[ssg_fan_control_ac](#)
 [address, 95, 95](#)
 [address_enabled, 95, 95](#)
 [requested_state, 95](#)
[ssg_fan_control_dc](#)
 [address, 95, 96](#)
 [address_enabled, 95, 96](#)
 [requested_state, 95](#)
[ssg_fault_afe_adc_register_bist, 182](#)
[ssg_fault_afe_config_mismatch, 182](#)
[ssg_fault_afe_cpu_bist_fresh_wdt, 183](#)
[ssg_fault_afe_ram_bist_fresh_wdt, 182](#)
[ssg_fault_afe_reset, 182, 183](#)
[ssg_fault_afe_rom_bist_fresh_wdt, 182](#)
[ssg_fault_afe_spi_cs_bist, 182](#)
[ssg_fault_afe_spi_data_bist, 182](#)
[ssg_fault_afe_thermistor_bist, 182](#)
[ssg_fault_afe_thermistor_bist_fresh_wdt, 183](#)
[ssg_fault_afe_wdt, 186](#)
[ssg_fault_bus_charge_current_over](#)
 [thresh, 75](#)
[ssg_fault_charge_current_over](#)
 [thresh, 76](#)
[ssg_fault_clock_accuracy_test_wdt, 187](#)
[ssg_fault_config_contactor_life, 189](#)
[ssg_fault_config_contactor_life_verify, 190](#)
[ssg_fault_contactor_end_of_life, 189](#)
 [thresh, 115](#)
[ssg_fault_contactor_end_of_life_wdt, 187](#)
[ssg_fault_contactor_life_sanity_check, 190](#)
[ssg_fault_contactor_life_verify_wdt, 187](#)
[ssg_fault_cpu_register_self_test_wdt, 187](#)
[ssg_fault_currents_mismatch, 181](#)
[ssg_fault_discharge_current_hi](#)
 [thresh, 76](#)
 [time_hyst, 76](#)
[ssg_fault_discharge_current_over](#)
 [thresh, 76](#)
[ssg_fault_gpi, 69, 185](#)
[ssg_fault_power_conn_temp_consistency, 185](#)
[ssg_fault_power_conn_temp_over, 184](#)
[ssg_fault_power_conn_therms_wdt, 187](#)
[ssg_fault_therm_circuit_fail, 189](#)
[ssg_fault_therms_wdt, 187](#)
[ssg_fault_unexpected_bus_voltage, 189](#)
[ssg_fault_vcoil_state_mismatch, 182, 189](#)
 [time_hyst, 191, 192](#)
[ssg_fault_vcoil_voltage_over, 189](#)
[ssg_fault_vcoil_voltage_range, 189](#)
[ssg_fault_voltage_over](#)
 [thresh, 78](#)
[ssg_fuse_therm](#)
 [temperature, 174](#)
 [temperature_float, 174](#)
[ssg_gpi_error_fault](#)
 [error, 69](#)
[ssg_gpi_error_warn](#)
 [error, 69](#)
[ssg_hw_disconnect](#)
 [disconnect_state, 98](#)
 [inverted, 99](#)
 [mode, 99](#)

ssg_on_board_therm temperature, 174 temperature_float, 174	Stack Switchgear AFE SPI Data BIST Error, 182
ssg_power_conn_therms temperature, 173 temperature_float, 173	Stack Switchgear AFE Thermistor BIST Failure, 182
ssg_shunt_therm temperature, 174 temperature_float, 174	Stack Switchgear AFE Thermistor BIST Watchdog, 183
ssg_shutdown value, 101	Stack Switchgear Clock Accuracy Test Watchdog, 187
ssg_temperature_short_shunt_detector enabled, 190	Stack Switchgear Contactor Life Memory Check, 189
ssg_therms_fresh, 184	Stack Switchgear Contactor Life Memory Watchdog, 187 , 190
ssg_trig_afe_afe_update_stalled, 183 , 183	Stack Switchgear Contactor Life Sanity Check, 190
ssg_trig_afe_cpu_bist_update_stalled, 183 , 183	Stack Switchgear Cpu Register Self Test Watchdog, 187
ssg_trig_afe_ram_bist_update_stalled, 183 , 183	Stack Switchgear Detected Unexpected Bus Voltage, 189
ssg_trig_afe_rom_bist_update_stalled, 183 , 183	Stack Switchgear GPI Fault, 185
ssg_trig_afe_temperature_update_stalled, 183 , 183	Stack Switchgear Power Connector Over Temperature, 184
ssg_trig_afe_thermistor_bist_update_stalled, 183 , 183	Stack Switchgear Power Connector Temperature Consistency, 185
ssg_trig_fan_control_aggregate, 95	Stack Switchgear Temperature Measurements Timeout, 187
ssg_trig_fan_control_charge, 94	Stack Switchgear Thermistor Circuit Fail, 189
ssg_trig_fan_control_discharge, 94	Stack Switchgear Vcoil Over Voltage, 189
ssg_uvlo_enable value, 99	Stack Switchgear Vcoil State Mismatch, 182 , 189
ssg_vcoil vcoil_wdt_disable, 182	Stack Switchgear Vcoil Voltage Range, 189
ssg_warn_contactor_end_of_life thresh, 114	Stack Under Voltage, 180
ssg_warn_fan_control_dc_error, 96 , 186	Stack/DC-Bus Current Mismatch, 181
ssg_warn_gpi, 69	stack_balancing_selector enable_voltage_balancer, 87 , 87
Stack Controller Configuration Consistency Check, 188	stack_balancing_throttling_estimator disable_balancing_temperature, 94 enable_balancing_temperature, 94
Stack Controller Factory Consistency Check, 188	stack_cell_voltage_balancer max_enable_current, 89 max_enable_temperature, 88 min_enable_current, 89 min_enable_voltage, 88 voltage_delta, 88
Stack Controller Factory Memory Check, 188	stack_charge_status hold_current, 57 , 105
Stack Controller RAM Test Watchdog, 187	stack_contactor address, 84 , 84 , 84 address_enable, 84 , 84 , 84 feedback_enable, 84 , 84 , 84 installed, 83 , 84 , 84 inverted, 84 , 84 , 84
Stack Controller ROM Test Watchdog, 187	stack_control auto_connect, 81
Stack High Voltage, 179	
Stack Low Voltage, 179	
Stack Over Voltage, 179	
Stack Switchgear AFE ADC Register BIST Error, 182	
Stack Switchgear AFE Configuration Mismatch, 182	
Stack Switchgear AFE CPU BIST Watchdog, 183	
Stack Switchgear AFE RAM BIST Watchdog, 182	
Stack Switchgear AFE Reset, 182	
Stack Switchgear AFE ROM BIST Watchdog, 182	
Stack Switchgear AFE SPI CS BIST Error, 182	

[connect_delay](#), [82](#), [83](#)
[disable_connecting](#), [82](#)
[disable_precharge](#), [81](#)
[disconnect_delay](#), [83](#)
[precharge_delay](#), [81](#), [82](#)
[precharge_max_current](#), [57](#), [82](#)
[requested_state](#), [98](#)
[stack_control.precharge_delay](#), [181](#)
[stack_control.precharge_max_current](#), [181](#)
[stack_control.voltage_mismatch_thresh](#), [181](#)
[stack_current_limit](#)
 [attack_settling_time](#), [86](#), [86](#)
 [charge_current_disable](#), [97](#)
 [charge_current_limit](#), [84](#)
 [decay_settling_time](#), [86](#)
 [discharge_current_disable](#), [97](#)
 [discharge_current_limit](#), [85](#)
 [max_charge_current](#), [57](#), [57](#), [86](#)
 [max_discharge_current](#), [86](#)
 [min_charge_current](#), [57](#), [86](#)
 [nonlinear_rolloff](#), [86](#)
 [temperature_charge_high](#), [73](#)
 [temperature_charge_low](#), [73](#)
 [temperature_charge_max](#), [73](#), [73](#)
 [temperature_charge_min](#), [73](#), [73](#)
 [temperature_discharge_high](#), [73](#)
 [temperature_discharge_low](#), [73](#)
 [temperature_discharge_max](#), [73](#), [73](#)
 [temperature_discharge_min](#), [73](#), [73](#)
 [voltage_cell_high](#), [71](#), [88](#)
 [voltage_cell_low](#), [71](#)
 [voltage_cell_max](#), [71](#), [71](#), [78](#)
 [voltage_cell_min](#), [71](#), [71](#)
 [voltage_stack_high](#), [78](#)
 [voltage_stack_low](#), [78](#)
 [voltage_stack_max](#), [78](#)
 [voltage_stack_min](#), [78](#), [78](#)
[stack_fault_cell_hi](#), [179](#)
 [thresh](#), [70](#)
[stack_fault_cell_lo](#), [179](#)
 [thresh](#), [71](#)
[stack_fault_cell_open_wire](#), [189](#), [190](#)
[stack_fault_cell_over](#), [178](#)
 [thresh](#), [70](#)
[stack_fault_cell_under](#), [179](#)
 [thresh](#), [71](#)
[stack_fault_cell_wdt](#), [186](#)
[stack_fault_charge_current_hi](#), [181](#)
 [thresh](#), [75](#), [76](#)
 [time_hyst](#), [76](#)
[stack_fault_charge_current_over](#), [181](#)
 [thresh](#), [75](#), [111](#)
[stack_fault_charge_therm_hi](#), [180](#)
 [thresh](#), [73](#)
[stack_fault_charge_therm_lo](#), [180](#)
 [thresh](#), [73](#)
[stack_fault_charge_therm_over](#), [180](#)
 [thresh](#), [73](#)
[stack_fault_charge_therm_under](#), [180](#)
 [thresh](#), [73](#)
[stack_fault_ci_therm_consistency](#), [189](#), [190](#)
 [thresh](#), [112](#), [189](#)
[stack_fault_ci_wdt](#), [187](#)
[stack_fault_contactor_feedback_fail](#), [182](#)
 [time_hyst](#), [192](#), [192](#)
[stack_fault_discharge_current_hi](#), [181](#)
 [thresh](#), [75](#)
[stack_fault_discharge_current_over](#), [181](#)
 [thresh](#), [76](#), [111](#)
[stack_fault_discharge_therm_hi](#), [180](#)
 [thresh](#), [73](#)
[stack_fault_discharge_therm_lo](#), [180](#)
 [thresh](#), [73](#)
[stack_fault_discharge_therm_over](#), [180](#)
 [thresh](#), [73](#)
[stack_fault_discharge_therm_under](#), [180](#)
 [thresh](#), [74](#)
[stack_fault_open_wire_wdt](#), [187](#)
[stack_fault_precharge_over_current](#), [182](#)
 [thresh](#), [57](#), [82](#)
[stack_fault_precharge_timeout](#), [181](#)
 [disabled](#), [82](#)
[stack_fault_short_shunt](#), [189](#)
[stack_fault_therm_circuit_fail](#), [189](#), [190](#)
[stack_fault_therm_wdt](#), [186](#)
[stack_fault_voltage_hi](#), [179](#)
 [thresh](#), [78](#)
[stack_fault_voltage_lo](#), [179](#)
 [thresh](#), [78](#)
[stack_fault_voltage_over](#), [179](#)
 [thresh](#), [78](#), [79](#)
[stack_fault_voltage_sum](#), [180](#)
 [thresh](#), [79](#)
[stack_fault_voltage_under](#), [180](#)
 [thresh](#), [78](#)
[stack_power](#)
 [current_gain](#), [104](#)
 [current_gain_limit](#), [104](#)
[stack_power_fresh](#), [183](#)
[stack_soc](#)
 [nominal_capacity](#), [60](#)
 [nominal_cycle_count](#), [61](#), [61](#)

soc, [175](#)
vempty, [62](#), [71](#)
vemptyavg, [62](#)
vfull, [63](#), [71](#)
vfullavg, [63](#)
stack_therm_poly
 coeff0, [102](#)
 coeff1, [102](#)
 coeff2, [102](#)
 coeff3, [102](#)
 coeff4, [102](#)
 coeff5, [102](#)
 coeff6, [102](#)
stack_trig_cell_hi
 thresh, [71](#)
stack_trig_cell_lo
 thresh, [71](#)
stack_trig_charge_current_hi
 thresh, [76](#)
stack_trig_charge_therm_hi
 thresh, [74](#)
stack_trig_charge_therm_lo
 thresh, [74](#)
stack_trig_discharge_current_hi
 thresh, [76](#)
stack_trig_discharge_therm_hi
 thresh, [74](#)
stack_trig_discharge_therm_lo
 thresh, [74](#)
stack_trig_uvlo_cell_voltage
 thresh, [109](#)
stack_trig_uvlo_stack_voltage
 thresh, [110](#)
stack_trig_voltage_hi
 thresh, [78](#)
stack_trig_voltage_lo
 thresh, [78](#)
stack_trigger_summary
 clear_faults, [98](#)
 fault, [97](#)
stack_uvlo_cell_voltage
 thresh, [71](#)
stack_uvlo_combined
 trig, [110](#)
stack_uvlo_stack_voltage
 thresh, [78](#)
stack_warn_cell_hi
 thresh, [71](#)
stack_warn_cell_lo
 thresh, [71](#)
stack_warn_cell_open_wire, [189](#)

stack_warn_charge_current_hi
 thresh, [75](#)
stack_warn_charge_therm_hi
 thresh, [73](#)
stack_warn_charge_therm_lo
 thresh, [73](#)
stack_warn_discharge_current_hi
 thresh, [75](#)
stack_warn_discharge_therm_hi
 thresh, [73](#)
stack_warn_discharge_therm_lo
 thresh, [73](#)
stack_warn_voltage_hi
 thresh, [78](#)
stack_warn_voltage_lo
 thresh, [78](#)

T

Temperature Measurement Watchdog, [186](#)
therm, [66](#)
 installed, [66](#), [66](#)
Thermistor Circuit Test, [189](#)
Thermistor Consistency Check, [189](#)
trigger_name
 disabled, [68](#), [68](#), [69](#)
 end_time_hyst, [68](#)
 latched, [69](#)
 thresh, [68](#), [68](#)
 time_hyst, [68](#)

V

Voltage Sum Check, [180](#)