



# Nuvation Energy Multi-Stack Controller

## NUVMSC3 Datasheet

Document ID: NE-DS-011 | Revision: 2.4, 2024-10-30

# Table of Contents

- 1. System Overview . . . . . 1
  - 1.1. Multi-Stack System Architecture . . . . . 2
  - 1.2. Features . . . . . 4
    - 1.2.1. Main Functions . . . . . 4
    - 1.2.2. Unified View Operator Interface . . . . . 4
    - 1.2.3. Communications & Data Analytics . . . . . 5
    - 1.2.4. Maintenance and Management . . . . . 5
- 2. Operating Limits . . . . . 6
  - 2.1. Electrical Characteristics . . . . . 6
  - 2.2. Environmental Conditions . . . . . 6
  - 2.3. Standards and Certifications . . . . . 7
- 3. Mechanical Installation . . . . . 8
  - 3.1. Dimensions and Weight . . . . . 8
  - 3.2. Installation Location and Position . . . . . 8
    - 3.2.1. Mounting Clearances . . . . . 8
- 4. Ordering Information . . . . . 10
- 5. Document Revision History . . . . . 11

## 1. System Overview

The Nuvation Energy Multi-Stack Controller aggregates all battery stacks within a multi-stack Energy Storage System. It enables operation of the overall system as a single unified battery, while still providing stack-level control.

This product functions as a central battery control hub for other control systems. These may include PCSs and/or energy controllers. Through this hub, such control systems can obtain and respond to battery data and send control commands to the battery system.

The Multi-Stack Controller can be used to manage up to 16 battery stacks in parallel, and will bring up stacks in the sequence best suited to the immediate use-case requirement, i.e. power, energy, or capacity.

The Multi-Stack Controller provides two crucial battery-level software interfaces for large, multi-stack battery applications:

### 1. Modbus TCP:

- Unified view of the entire battery conforming to open energy standards
- Conforms to SunSpec Energy Storage Models: 802, 803, 804, 805 Models
- Used directly by inverters and other grid infrastructure implementing the SunSpec Energy Storage Models (Draft 4)

### 2. Web-based configuration and diagnostics:

- Hosts web-based tools that can be accessed from common web browsers
- Used to configure settings and view diagnostic information for the entire battery system

A few key system-level features that are also provided are:

- System-wide statistics for voltages, temperatures, and currents
- Current limiting algorithms for multi-stack battery systems
- State-of-Charge algorithms for multi-stack battery systems
- NTP client for BMS time synchronization



**Figure 1. Nuvation Energy Multi-Stack Controller**

## 1.1. Multi-Stack System Architecture

A typical multi-stack system, equipped with Nuvation Energy's suite of BMS products, is illustrated in [Figure 2, "Multi-Stack Controller system diagram"](#). There is a hierarchy of battery management involved, each product fulfilling its role at a different level:

- At the cell level, a Cell Interface module measures voltage/temperature and balances cells as required.
- At the stack level, a Stack Switchgear unit measures current and connects/disconnects its stack as required, as well as incorporates other stack safety features. Battery safety is handled at the stack level.
- At the system level, a Nuvation Energy Multi-Stack Controller unit manages all stacks as described above.

For a given stack, the daisy-chained Cell Interface modules report data to and receive direction from the Stack Switchgear. In turn, the Stack Switchgear reports data to and receives direction from the Multi-Stack Controller. Here, a unified view and central control of the multi-stack system is provided to the user as well as any external devices.



Cell Interface modules and Stack Switchgear units are sold separately. Datasheets, along with product manuals, are available online at <https://nuvationenergy.com/technical-resources>.

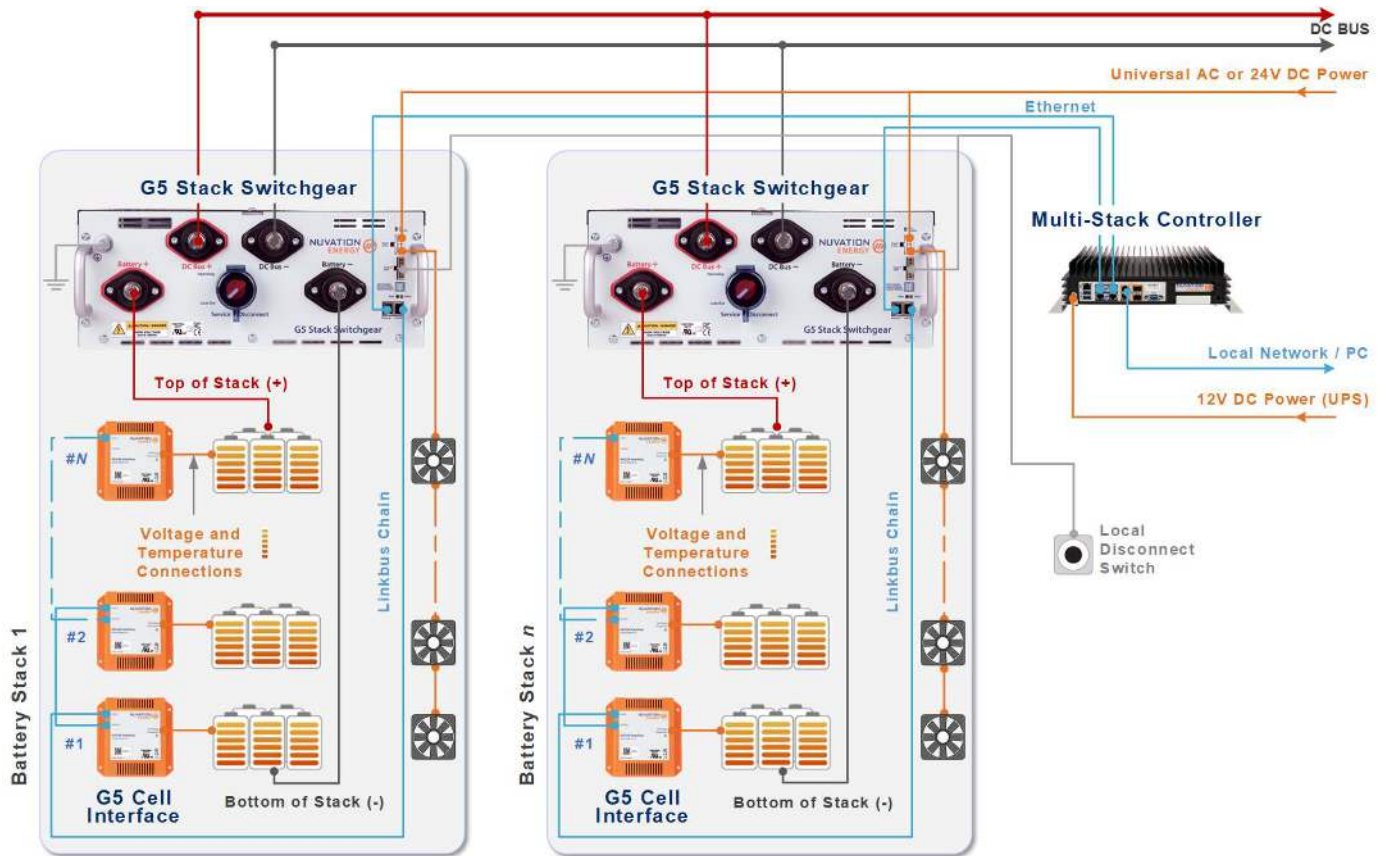

**Figure 2. Multi-Stack Controller system diagram**

The Multi-Stack Controller is offered in variants based on the number of battery stacks to which it will be connected. Variants are available in 4-stack increments, up to a maximum of 16 stacks.

The Multi-Stack Controller is available in a compact hardware form-factor or in a rack-mounted hardware form-factor. This document describes the compact form-factor. The document for the rack-mount form-factor is available upon request.

Designed in compliance with SunSpec (<https://sunspec.org/>), the Nuvation Energy Multi-Stack Controller was created specifically for integration with a wide range of batteries and inverters, and is designed to work with the following Nuvation Energy BMS products:

- G5 Stack Switchgear
- G4 Stack Switchgear
- Stack Controller
- Low-Voltage BMS

Orderable part numbers are listed in [Section 4, "Ordering Information"](#).

## 1.2. Features

### 1.2.1. Main Functions

**Manages multiple stacks**

Manage up to 16 stacks.

**Provides Unified View of Entire Battery**

Access diagnostics and performance data of entire multi-stack battery from a single unified user interface.

**Provides Remote Access**

Remote access for data analytics or for viewing and adjusting battery operation remotely via web browser on a PC, tablet computer, or even on a smartphone.

**Automates System-Wide Fault Response**

Manually or automatically identify and act upon faults anywhere in the battery pack.

**Communications**

Communicate securely over Ethernet. Provides unified interface for site controllers to multiple stacks.

**Automatic Pack Connection**

Allows the BMS to manage the connected state of all battery stacks within the pack. When requested, the Multi-Stack Controller will connect all stacks if they do not violate the pack connection voltage limit. Stacks are automatically connected when the limit is no longer violated (i.e. when the stack voltage becomes close enough to the pack voltage that is safe to connect).

**Maximize Pack Uptime and Connection**

Provides a flexible configuration to manage battery stack faults at a pack level. A Nuvation Energy support technician can configure a battery pack to tolerate a specified number of stacks that fault and disconnect from the DC bus. The Multi-Stack Controller allows the pack to remain operational and manage the reduced power capacity of the battery.

### 1.2.2. Unified View Operator Interface

A Browser user interface, which supports Chrome and Firefox, provides a view of:

**Statistics View**

Monitor pack-level statistics for voltage, temperature, and current across all cells.

**Real-Time View**

Monitor measurement and control information in real-time.

**Aggregate State-of-Charge**

View State-of-Charge calculated values for the entire battery.

**Flow-Through I/O**

Control all points in the BMS from a single interface.

**Communications Status**

Reports networking communication status and communication issues from stacks within the pack.

**Faults and Warnings**

Monitor all system-wide faults and warnings or—for a finer level of control—drill down into detailed battery pack diagnostics.

## 1.2.3. Communications & Data Analytics

**Isolated BMS Network Traffic**

Separate Ethernet ports isolate BMS network traffic from external network traffic, helping ensure your Energy Storage System is hardened and reliable.

**Inverter Support**

Modbus TCP supports SunSpec Energy Storage Models for connection to PCSs as well as other external systems through multiple concurrent client connections.

## 1.2.4. Maintenance and Management

**Multi-Stack Current Limiting**

Determine operating current limits for entire pack, which can be read by the external system to control the inverter, protecting the battery pack from over-charging or discharging.

**Pack-Level Fault Response**

A highly configurable architecture allows a Nuvation Energy support technician to specify system faults and desired responses. The Multi-Stack Controller flags faults anywhere in the battery pack and automatically takes preventive action to keep the battery functional and healthy.

**Servicing**

Bring stacks online/offline for service, maintenance, modifications, etc. Selectively connect multiple stacks to the DC power bus.

**Network Environment Flexibility**

A multi-socket Ethernet interface allows concurrent operation of both local and remote operator panels, monitoring data and interfacing with inverters over Modbus TCP. SFP+ interfaces allow long-distance fibre connectivity without external hardware.

**Provides Remote Support**

The Multi-Stack Controller provides the option of a secure VPN connection to a Nuvation Energy server which grants Nuvation Energy support engineers remote access to check on the health of the battery pack and aid the local site commissioning team.

## 2. Operating Limits



Exceeding the maximum ratings will damage the module.

### 2.1. Electrical Characteristics

Symbol	Parameter	Conditions	Min	Typ	Max	Units
<b>Power Specifications</b>						
+Vin	Input Voltage	-	11.4	12	12.6	V DC
	Input Current	+Vin = 12 V DC	-	7.5	12.5	A DC
<b>Ethernet Specifications</b>						
ETH RJ45: 1-4	Ethernet Connection Speed	10BASE-T 100BASE-TX 1000BASE-T	10	-	1000	Mb/s
ETH RJ45: 5,7	Ethernet Connection Speed	1GBASE-T 10GBASE-T	1	-	10	Gb/s
ETH Twisted_Pair: 1-4	Ethernet Cable Rating	-	Cat 5e	-	Cat 6	
ETH Twisted_Pair: 5,7	Ethernet Cable Rating	-	Cat 6	-	-	
ETH SFP+: 6,8	SFP+ Port Speed	-	1	-	10	Gb/s
ETH_Connector	Ethernet jack rating	-	-	Cat6	-	

### 2.2. Environmental Conditions

Symbol	Parameter	Conditions	Min	Typ	Max	Units
<b>Thermal Specifications</b>						
T <sub>a</sub>	Operating Temperature	-	5	25	40	°C
	Storage Temperature	-	-40	25	70	°C
<b>Humidity Specifications</b>						
RH	Operational RH	Non-Condensing	8	-	90	%
	Storage RH	Non-Condensing	5	-	95	%
<b>Shock and Vibration Specifications</b>						
Vertical	Vertical Shock/Vibration	-	-	-	10	m/s <sup>2</sup>
Longitudinal	Longitudinal Shock/Vibration	-	-	-	10	m/s <sup>2</sup>
Transverse	Transverse Shock/Vibration	-	-	-	10	m/s <sup>2</sup>
Pulse Vibration	On each axis	-	-	-	245	m/s <sup>2</sup>



If the Multi-Stack Controller is stored at temperatures below 5 °C, it must be warmed up in a 20 °C or warmer environment for 45 minutes before applying power. Powering the unit below 5 °C may impact data logging or cause other unexpected behaviour.

## 2.3. Standards and Certifications

The Multi-Stack Controller has been designed to meet the requirements of SAE J2464 (shock) and SAE J2380 (random vibration).

The following directives and standards apply to the Multi-Stack Controller:

- EMC/EMI: 2014/30/EU (EMC Directive)
- Electromagnetic Compatibility Regulations 2016
- FCC Part 15 Subpart B
- ICES-003
- VCCI 32-1
- AS/NZS CISPR 32
- BS/EN55032
- BS/EN55035
- BS/EN 61000-3-2
- BS/EN 61000-3-3
- BS/EN 61000-4-2
- BS/EN 61000-4-3
- BS/EN 61000-4-4
- BS/EN 61000-4-5
- BS/EN 61000-4-6
- BS/EN 61000-4-8
- BS/EN 61000-4-11
- Green Environment: 2011/65/EU (RoHS Directive)
- EC 1907/2006 (REACH)
- 2012/19/EU (WEEE Directive)
- Product Safety: 2014/35/EU (LVD Directive)
- Electrical Equipment (Safety) Regulations 2016
- UL/CSA 62368-1 (USA and Canada)
- IEC 62368-1

## 3. Mechanical Installation

### 3.1. Dimensions and Weight

The overall dimensions of the Multi-Stack Controller are 340 mm × 218.5 mm × 89.8 mm.

The Multi-Stack Controller module weighs approximately 4.5 kg (9.9 lb).

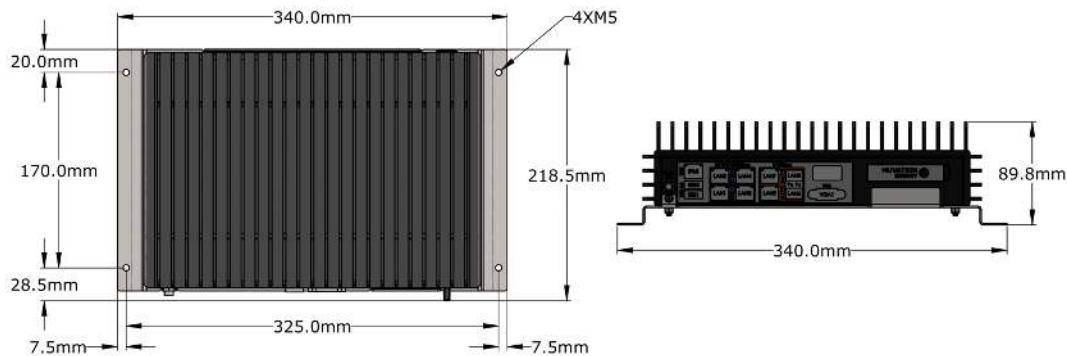

**Figure 3. Mechanical Drawing of Multi-Stack Controller**

### 3.2. Installation Location and Position

The Multi-Stack Controller is rated to operate in the temperature range of 5 °C to 40 °C. It is designed for indoor use.

For best thermal performance, the Multi-Stack Controller should be mounted to a flat vertical surface such that the face with the Ethernet / Power connectors is pointing up.

The Multi-Stack Controller can be mounted using four M5 screws.

#### 3.2.1. Mounting Clearances

Extra space should be provided around the module to allow for cable connections, easy installation and maintenance, and to provide adequate fan-less cooling. The spatial clearance is illustrated below.

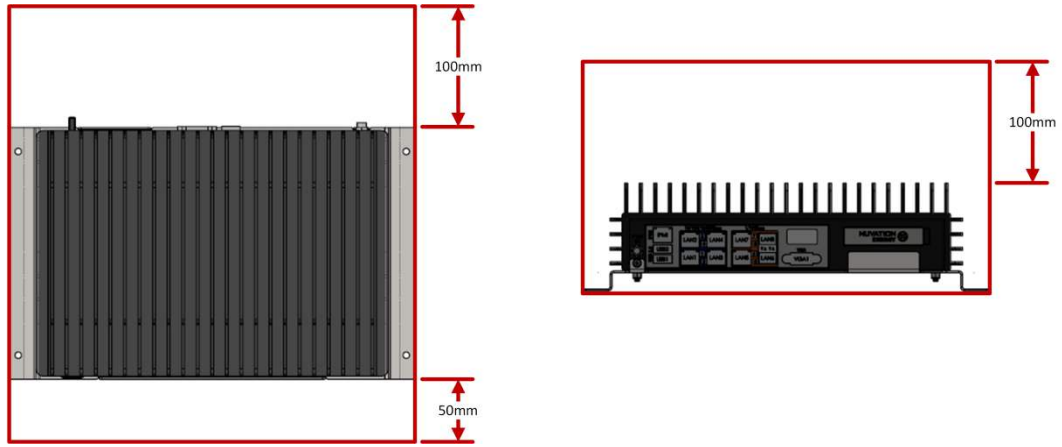

**Figure 4. Multi-Stack Controller Restricted Areas**

## 4. Ordering Information

This section provides orderable part numbers for Nuvation Energy's offerings of Multi-Stack Controller modules and related accessories.

Product Part Number	Product Name
NUVMSC3-04S-C	Multi-Stack Controller, Compact, up to 4 stacks
NUVMSC3-08S-C	Multi-Stack Controller, Compact, up to 8 stacks
NUVMSC3-12S-C	Multi-Stack Controller, Compact, up to 12 stacks
NUVMSC3-16S-C	Multi-Stack Controller, Compact, up to 16 stacks

Depending on the region the product is shipped to, either a NEMA 5-15P or CEE 7/7 12V lockable power adapter is included in the box.

## 5. Document Revision History

Revision	Date	Details
1.0	2020-12-18	Initial Release
2.0	2021-10-22	Updated hardware platform specifications
2.1	2022-02-01	Updated specifications
2.2	2022-05-17	Updated hardware and software specifications
2.3	2023-11-10	Updated number of stacks supported. Updated hardware and software specifications
2.4	2024-10-30	Updated ordering information

*From time to time Nuvation Energy will make updates to products in response to changes in available technologies, client requests, emerging energy storage standards, and other industry requirements. The product specifications in this document, therefore, are subject to change without notice.*

© 2024 Nuvation Energy